

AV RECEIVER/AV AMPLIFIER

RX-V361/HTR-6030/DSP-AX361

SERVICE MANUAL

IMPORTANT NOTICE

This manual has been provided for the use of authorized YAMAHA Retailers and their service personnel. It has been assumed that basic service procedures inherent to the industry, and more specifically YAMAHA Products, are already known and understood by the users, and have therefore not been restated.

WARNING: Failure to follow appropriate service and safety procedures when servicing this product may result in personal injury, destruction of expensive components, and failure of the product to perform as specified. For these reasons, we advise all YAMAHA product owners that any service required should be performed by an authorized YAMAHA Retailer or the appointed service representative.

IMPORTANT: The presentation or sale of this manual to any individual or firm does not constitute authorization, certification or recognition of any applicable technical capabilities, or establish a principle-agent relationship of any form.

The data provided is believed to be accurate and applicable to the unit(s) indicated on the cover. The research, engineering, and service departments of YAMAHA are continually striving to improve YAMAHA products. Modifications are, therefore, inevitable and specifications are subject to change without notice or obligation to retrofit. Should any discrepancy appear to exist, please contact the distributor's Service Division.

WARNING: Static discharges can destroy expensive components. Discharge any static electricity your body may have accumulated by grounding yourself to the ground buss in the unit (heavy gauge black wires connect to this buss).

IMPORTANT: Turn the unit OFF during disassembly and part replacement. Recheck all work before you apply power to the unit.

CONTENTS

TO SERVICE PERSONNEL	2	DISPLAY DATA	39
FRONT PANELS	3-4	IC DATA	40-54
REAR PANELS	5-9	BLOCK DIAGRAMS	55-56
REMOTE CONTROL PANELS	9	PIN CONNECTION DIAGRAMS	57
SPECIFICATIONS / 参考仕様	10-12	PRINTED CIRCUIT BOARDS	58-70
INTERNAL VIEW	13	SCHEMATIC DIAGRAMS	71-80
DISASSEMBLY PROCEDURES / 分解手順	14-16	REPLACEMENT PARTS LIST	81-95
UPDATING FIRMWARE / ファームウェアの書き込み	17-19	REMOTE CONTROL	96-98
SELF DIAGNOSIS FUNCTION (DIAG) / 自己診断機能 (ダイアグ)	20-37	Advanced setup / すべての設定を初期設定に戻す	99



このサービスマニュアルは、エコマーク認定の再生紙を使用しています。
This Service Manual uses recycled paper.

101040

© 2007 YAMAHA CORPORATION All rights reserved.
This manual is copyrighted by YAMAHA and may not be copied or
redistributed either in print or electronically without permission.



YAMAHA

YAMAHA CORPORATION
P.O.Box 1, Hamamatsu, Japan

'07.02

RX-V361/HTR-6030/
DSP-AX361

■ TO SERVICE PERSONNEL

1. Critical Components Information
Components having special characteristics are marked ⚠ and must be replaced with parts having specifications equal to those originally installed.
 2. Leakage Current Measurement (For 120V Models Only)
When service has been completed, it is imperative to verify that all exposed conductive surfaces are properly insulated from supply circuits.
- Meter impedance should be equivalent to 1500 ohms shunted by 0.15μF.

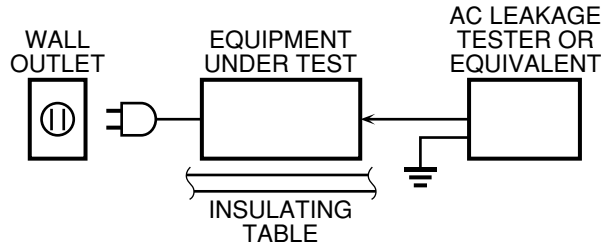

- Leakage current must not exceed 0.5mA.
- Be sure to test for leakage with the AC plug in both polarities.



For U model

“CAUTION”

“F2251: FOR CONTINUED PROTECTION AGAINST RISK OF FIRE, REPLACE ONLY WITH SAME TYPE 6A, 125V FUSE.”

For C model

CAUTION

F2251: REPLACE WITH SAME TYPE 6A, 125V FUSE.

ATTENTION

F2251: UTILISER UN FUSIBLE DE RECHANGE DE MÊME TYPE DE 6A, 125V.

WARNING: CHEMICAL CONTENT NOTICE!

The solder used in the production of this product contains LEAD. In addition, other electrical/electronic and/or plastic (where applicable) components may also contain traces of chemicals found by the California Health and Welfare Agency (and possibly other entities) to cause cancer and/or birth defects or other reproductive harm.

DO NOT PLACE SOLDER, ELECTRICAL/ELECTRONIC OR PLASTIC COMPONENTS IN YOUR MOUTH FOR ANY REASON WHATSOEVER!

Avoid prolonged, unprotected contact between solder and your skin! When soldering, do not inhale solder fumes or expose eyes to solder/flux vapor!

If you come in contact with solder or components located inside the enclosure of this product, wash your hands before handling food.

About lead free solder / 無鉛ハンダについて

All of the P.C.B.s installed in this unit and solder joints are soldered using the lead free solder.

Among some types of lead free solder currently available, it is recommended to use one of the following types for the repair work.

- Sn + Ag + Cu (tin + silver + copper)
- Sn + Cu (tin + copper)
- Sn + Zn + Bi (tin + zinc + bismuth)

Caution:

As the melting point temperature of the lead free solder is about 30°C to 40°C (50°F to 70°F) higher than that of the lead solder, be sure to use a soldering iron suitable to each solder.

本機に搭載されているすべての基板およびハンダ付けによる接合部は無鉛ハンダでハンダ付けされています。

無鉛ハンダにはいくつかの種類がありますが、修理時には下記のような無鉛ハンダの使用を推奨します。

- ・ Sn+Ag+Cu(錫+銀+銅)
- ・ Sn+Cu(錫+銅)
- ・ Sn+Zn+Bi(錫+亜鉛+ビスマス)

注意:

無鉛ハンダの融点温度は通常の鉛入りハンダに比べ30~40°C程度高くなっていますので、それぞれのハンダに合ったハンダごてをご使用ください。

FRONT PANELS

RX-V361 (U, C models)

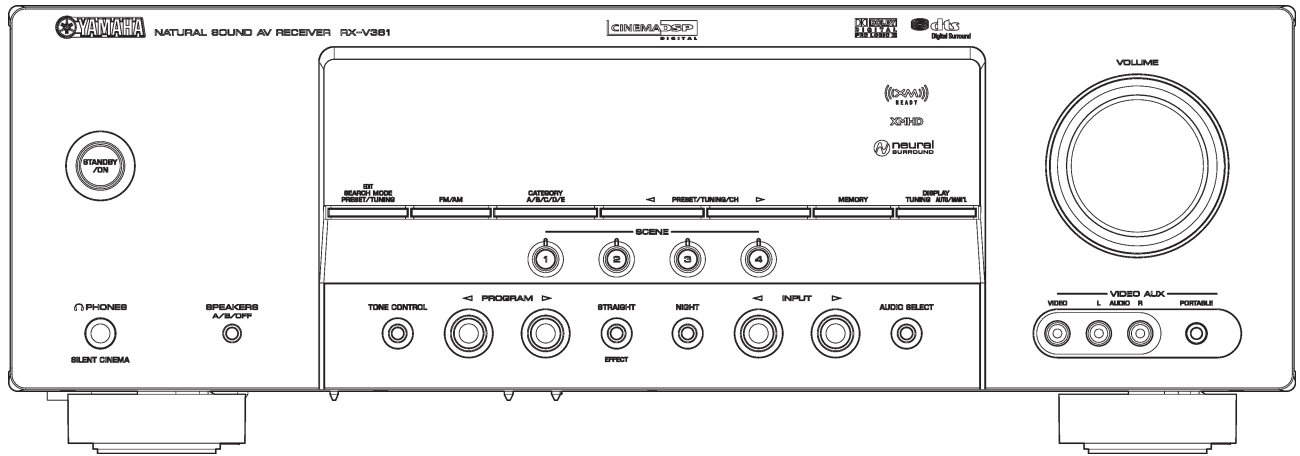

RX-V361 (R, T, K, A, B, G, E, L models)

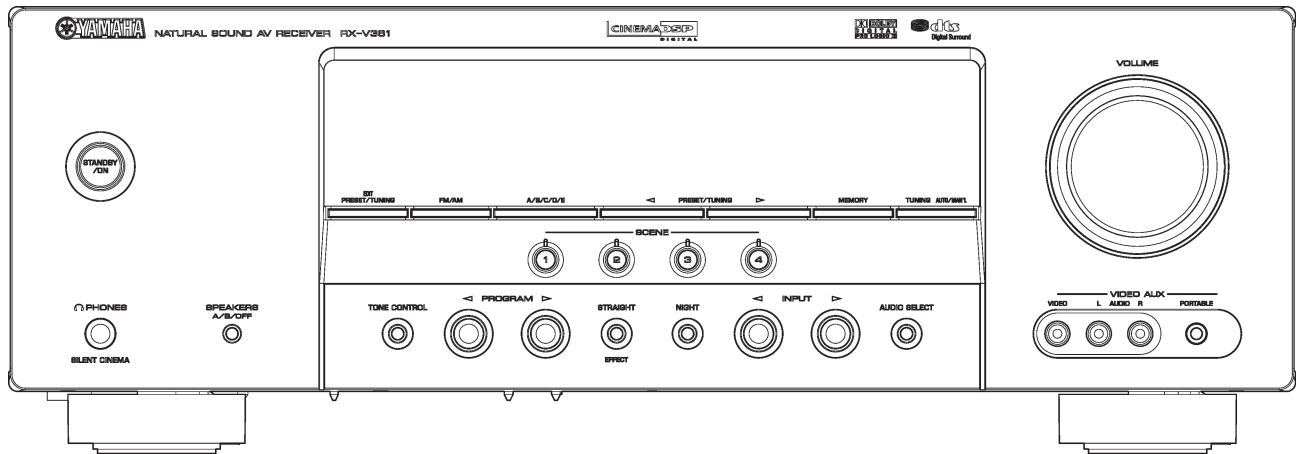

HTR-6030 (U, C models)

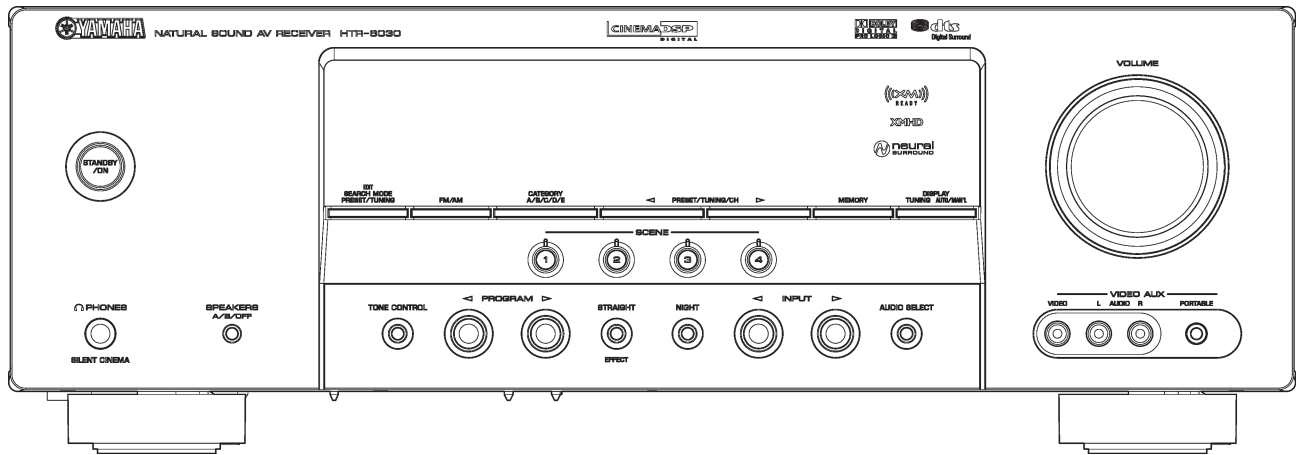

HTR-6030 (R, T, K, A, G, E models)

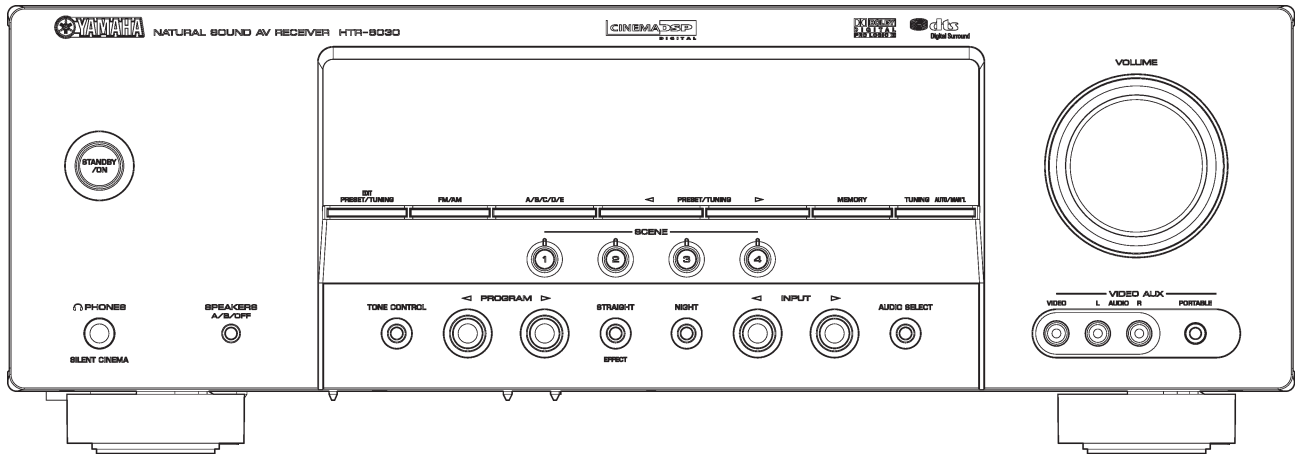

DSP-AX361 (J model)

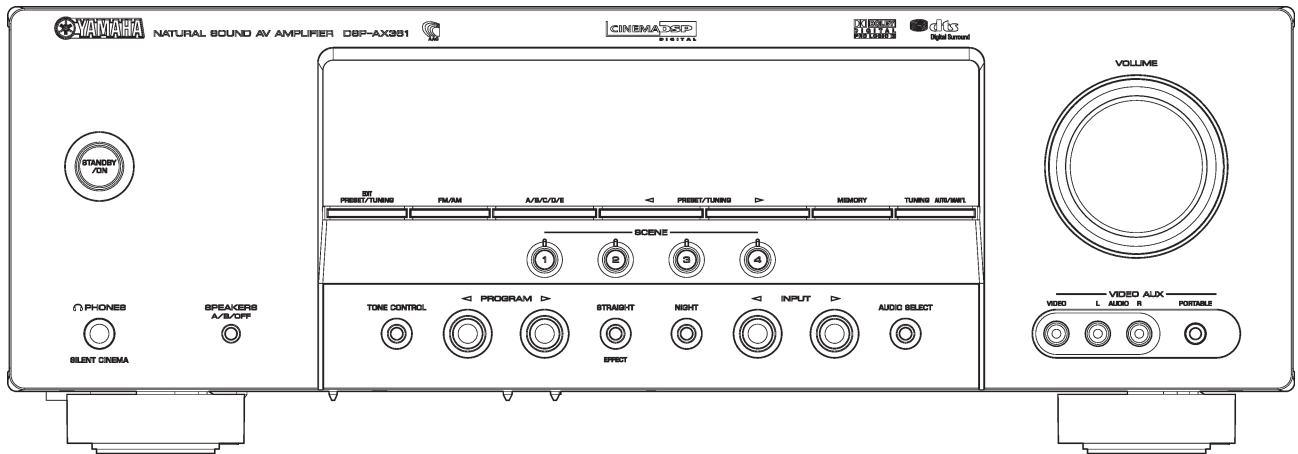

RX-V361 (K model)

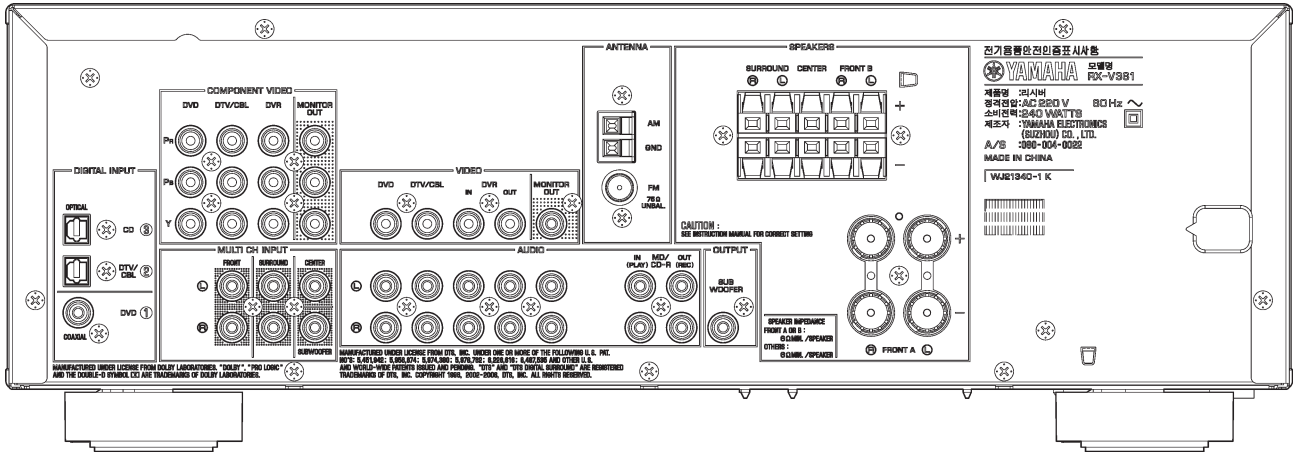

RX-V361 (A model)

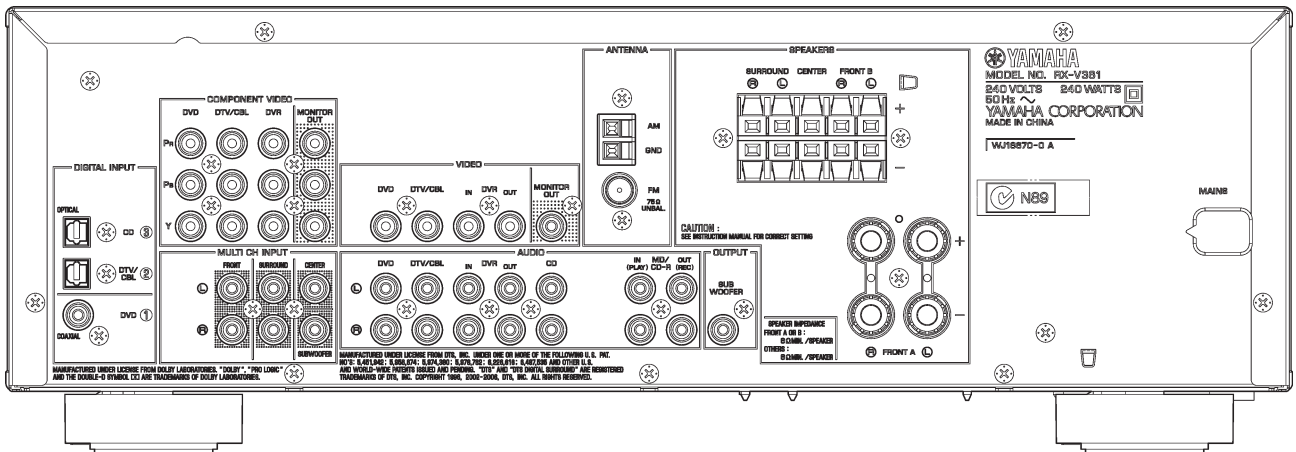

RX-V361 (B, G, E models)

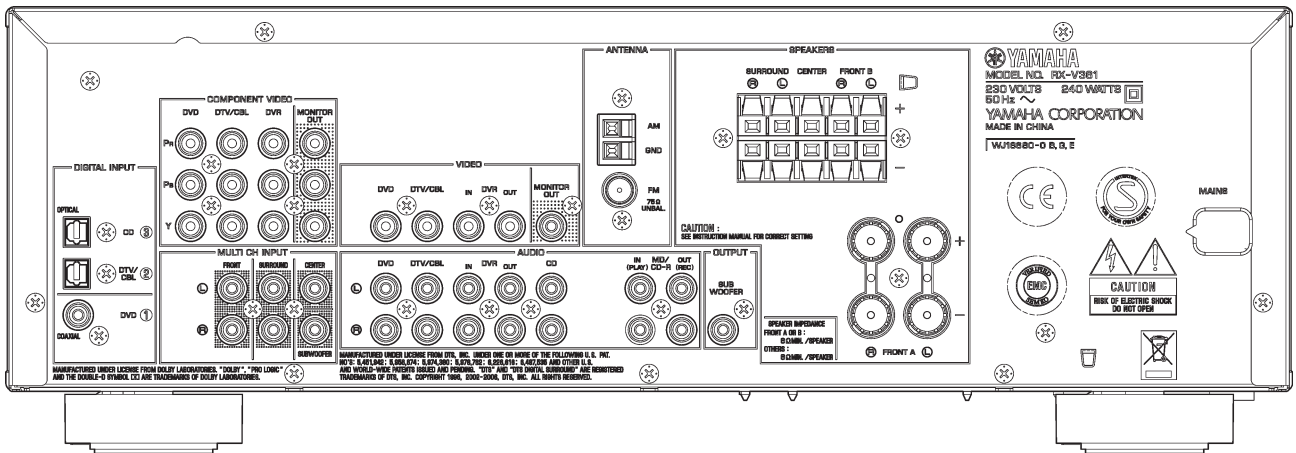

RX-V361 (L model)

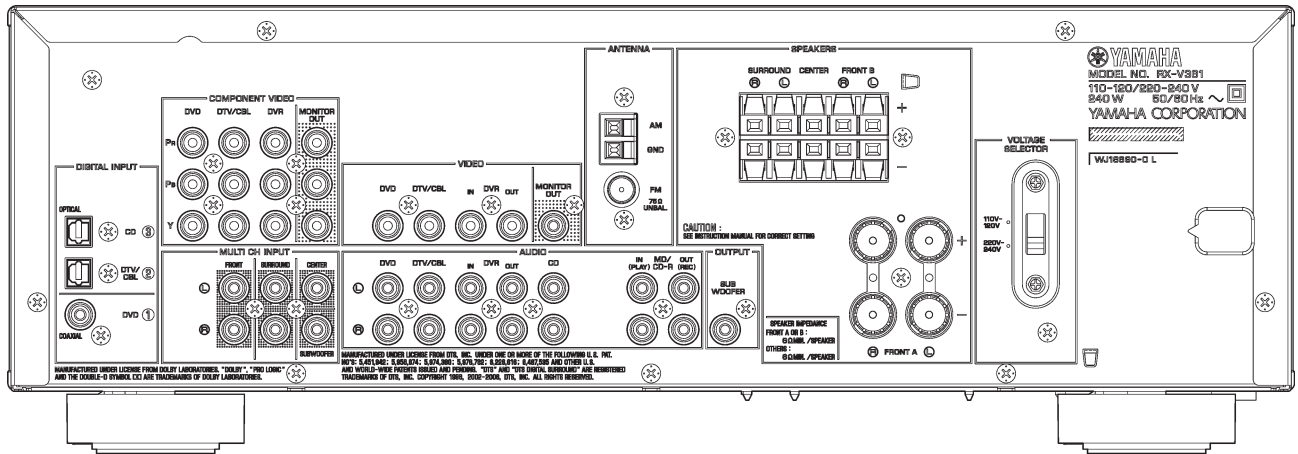

HTR-6030 (U, C models)

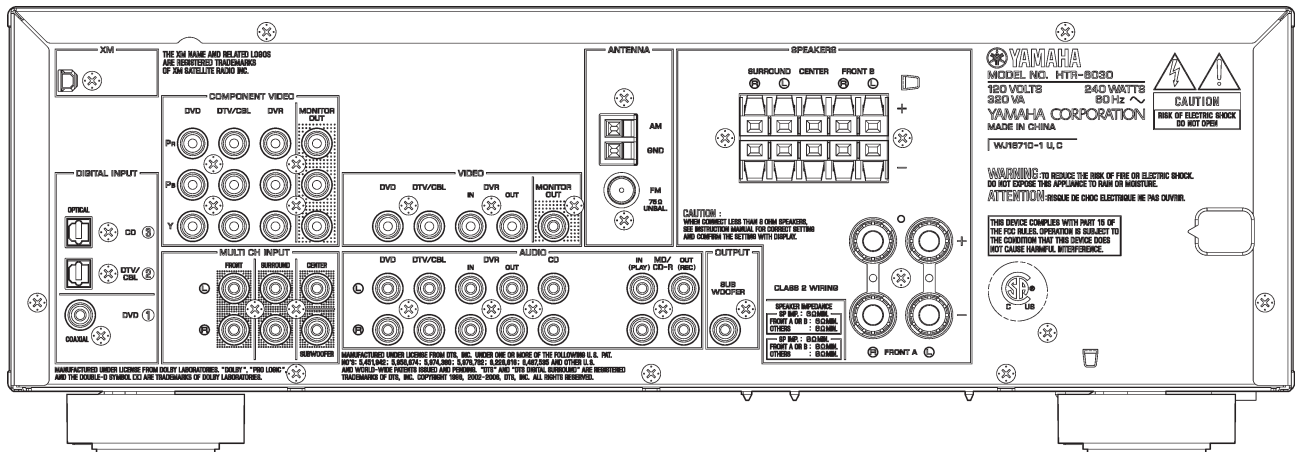

HTR-6030 (R model)

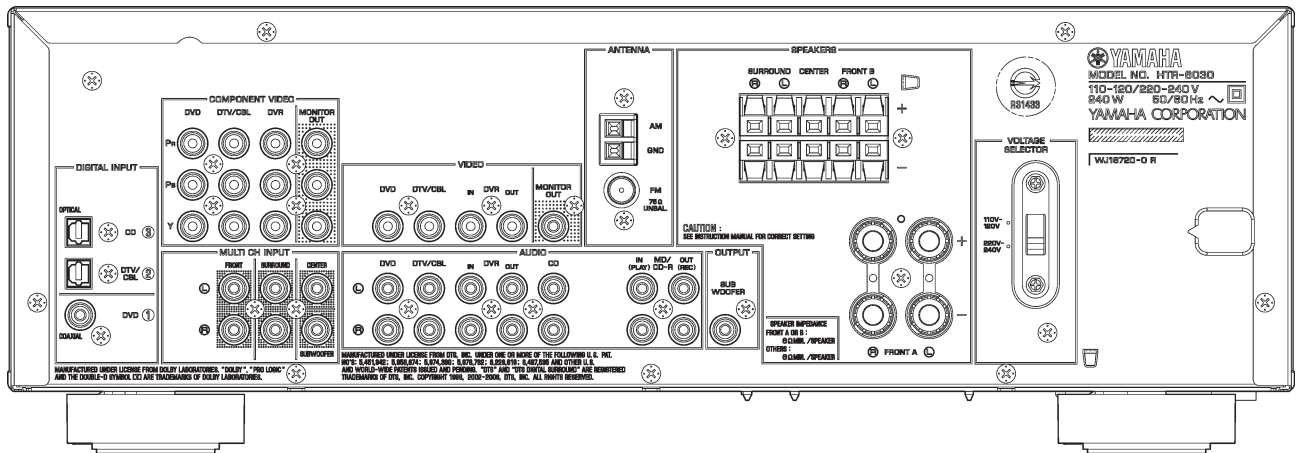

HTR-6030 (T model)

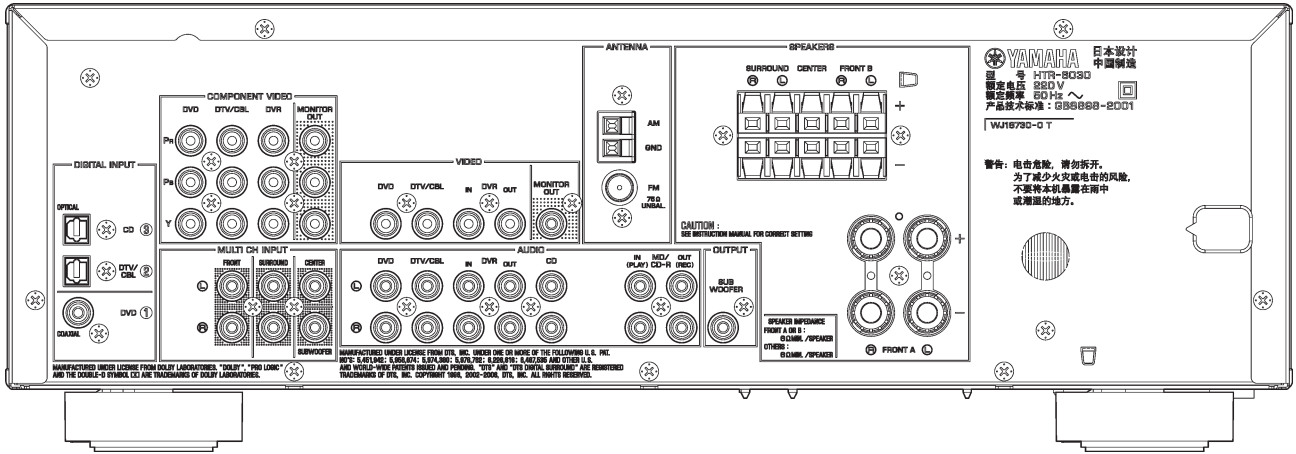

HTR-6030 (K model)

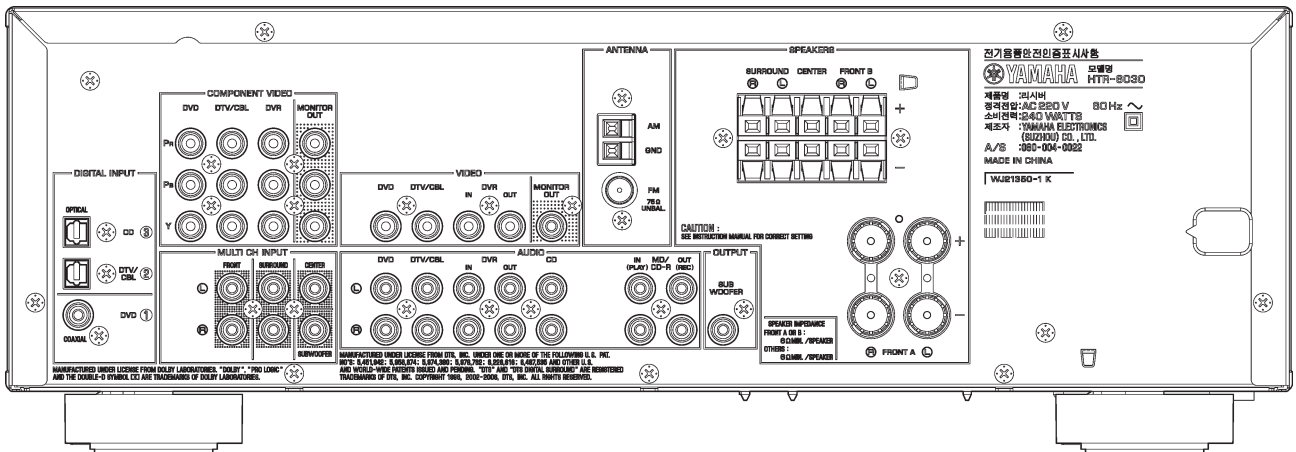

HTR-6030 (A model)

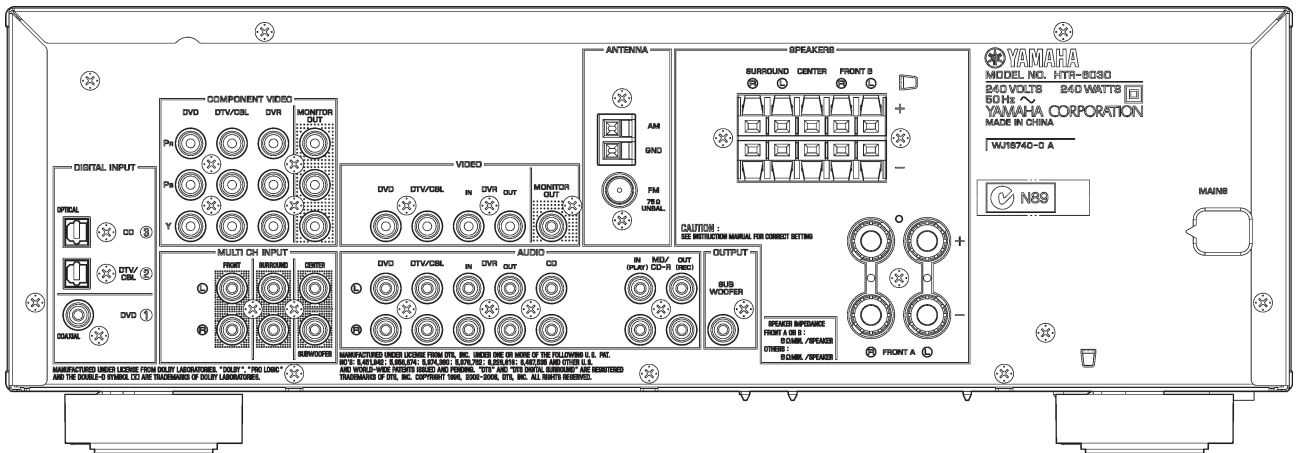

HTR-6030 (G, E models)

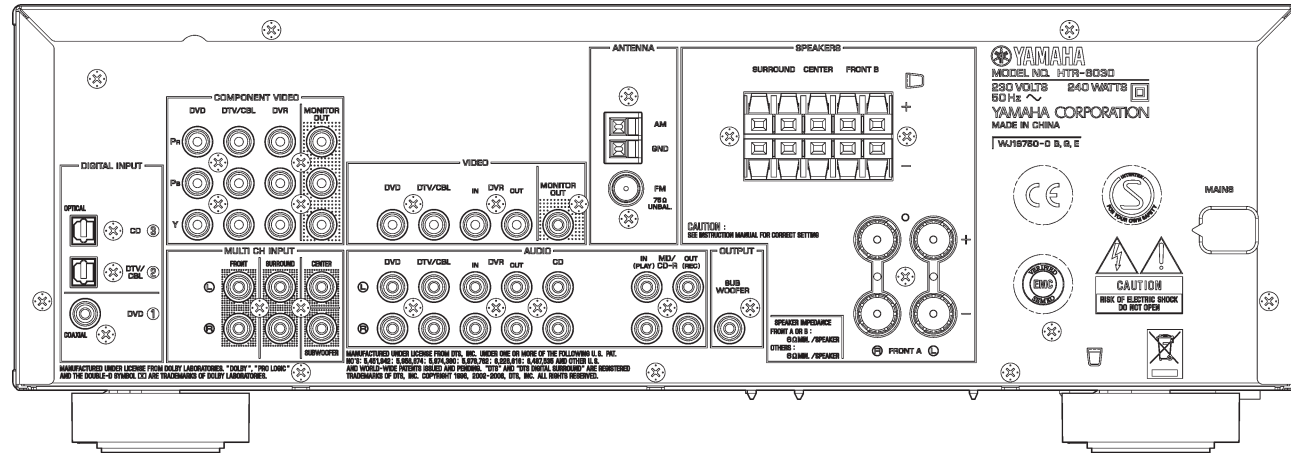

DSP-AX361 (J model)

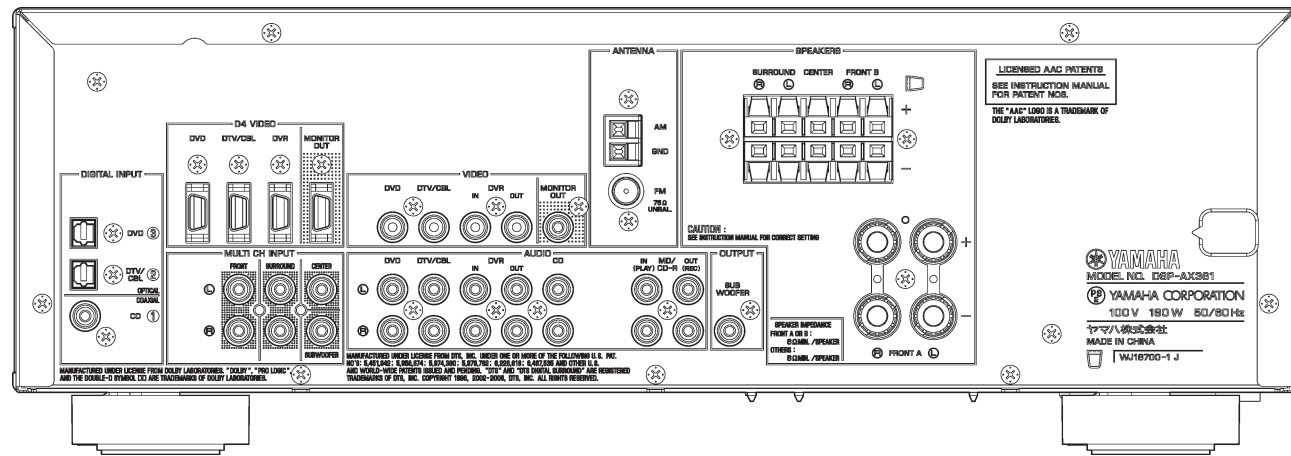

REMOTE CONTROL PANELS

- RAV311
RX-361 (U, C models)
HTR-6030 (U, C models)

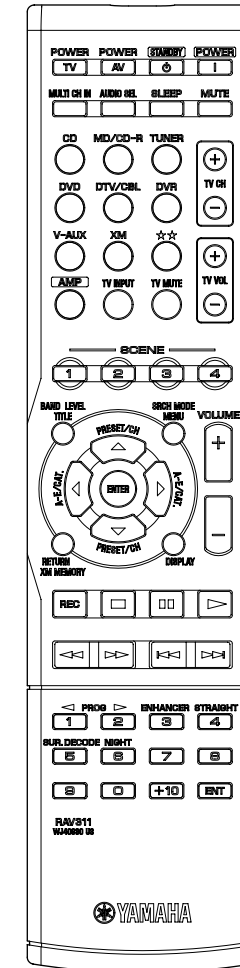

- RAV312
RX-V361 (R, T, K, A, L models)
HTR-6030 (R, T, K, A models)
DSP-AX361 (J model)

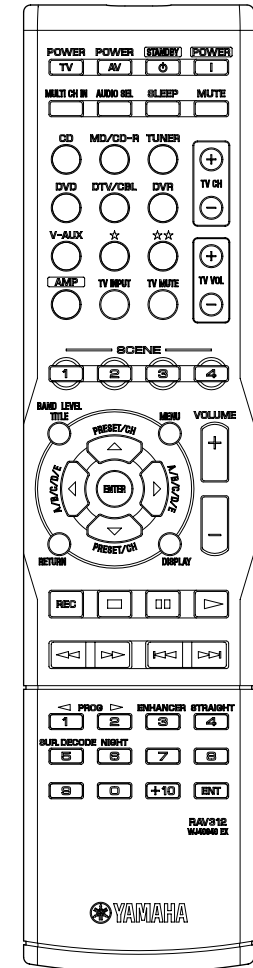

- RAV28
RX-V361 (B, G, E models)
HTR-6030 (G, E models)

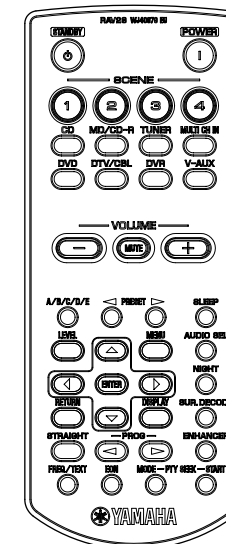

■ SPECIFICATIONS / 参考仕様

■ Audio Section / オーディオ部

Minimum RMS Output Power (Power Amp. Section) / 定格出力(パワーアンプ部) (1 kHz, 0.9 % THD, 8 ohms)

FRONT L/R, CENTER, SURROUND L/R
U, C models (8 ohms) 100 W/ch
R, T, K, A, B, G, E, L, J models (6 ohms) 100 W/ch

Maximum Power / 実用最大出力 (JEITA) (1 kHz, 10 % THD)
FRONT L/R, CENTER, SURROUND L/R

U, C models (8 ohms) 135 W/ch
R, T, K, A, L, J models (6 ohms) 135 W/ch

Max. Power Per Channel/ Max.パワー

(1 kHz, 0.7 % THD, 4 ohms) (B, G, E models)
FRONT L/R, CENTER, SURROUND L/R.... 105 W or more

IEC Power / IECパワー

(1 kHz, 0.1 % THD, 8 ohms) (B, G, E models)
MAIN L/R 90 W or more

Dynamic Power Per Channel / ダイナミックパワー (IHF)

U, C models
(8/6/4/2 ohms) 110/130/175/185 W
R, T, K, A, B, G, E, L, J models
(6/4/2 ohms) 105/135/165 W

Dynamic Headroom / ダイナミックヘッドルーム

U, C models (8 ohms) 0.41 dB

Input Sensitivity/Input Impedance / 入力感度/入力インピーダンス

(1 kHz, 100 W / 6 ohms)
CD, etc. 200 mV / 47 k-ohms
MULTI CH INPUT

FRONT L/R, CENTER, SURROUND L/R, SUBWOOFER
..... 200 mV / 47 k-ohms

Maximum Input Signal / 最大許容入力 (1 kHz, 0.5 % THD, Effect on)

(U, C, R, T, K, A, B, G, E, J models)
CD, etc. 2.0 V or more

Output Level/Output Impedance / 出力電圧/出力インピーダンス

REC OUT 200 mV / 1.2 k-ohms
SUBWOOFER (2 ch STEREO and FRONT SP: Small)
..... 4 V / 1.2 k-ohms

Headphone Jack Rated Output/Impedance /

ヘッドフォン出力/出力インピーダンス
CD, etc. (1 kHz, 50 mV, 8 ohms) 150 mV / 100 ohms

Frequency Response / 周波数特性

(10 Hz to 100 kHz)
CD, etc. to FRONT L/R 0 / -3.0 dB
(10 Hz to 20 kHz)
V-AUX to FRONT L/R 0 / -3.0 dB

Total Harmonic Distortion / 全高調波歪率 (1 kHz, 50 W, 8 ohms)

CD, etc. (2ch stereo) to FRONT L/R SP OUT
..... 0.06 % or less

Signal to Noise Ratio / 信号対雑音比 (IHF-A Network)

CD, etc. (STEREO) to Input shorted SP OUT
250 mV 100 dB or more

Residual Noise / 残留ノイズ (IHF-A Network)

FRONT L/R SP OUT 150 μV or less

Channel Separation / チャンネルセパレーション

CD, etc. (Input 5.1 k-ohms shorted, 1 kHz / 10 kHz)
..... 60 dB or more / 45 dB or more

Tone Control Characteristics / トーンコントロール特性

BASS
Boost/Cut ±10 dB (100 Hz)
TREBLE
Boost/Cut ±10 dB (20 kHz)

Filter Characteristics / フィルタ特性

FRONT, CENTER, SURROUND small (H.P.F.)
..... fc=40/60/80/90/100/110/120/160/200 Hz, 12 dB/oct.
SUBWOOFER (L.P.F.)
..... fc=40/60/80/90/100/110/120/160/200 Hz, 24 dB/oct.

■ Video Section / ビデオ部

Video Signal Type (Gray back) / ビデオ信号方式(グレーバック)

U, C, R, K, J models NTSC
T, A, B, G, E, L models PAL

Composite Video Signal Level / コンポジットビデオ信号

..... 1 Vp-p / 75 ohms
Component Signal Level / コンポーネントビデオ信号
(U, C, R, T, K, A, B, G, E, L models)
Y 1 Vp-p / 75 ohms

D4-Video Signal Level / D4ビデオ信号 [J model]

Cb/Cr 0.7 Vp-p / 75 ohms

Video Maximum Input Level / ビデオ最大許容入力

..... 1.5 Vp-p or more

Signal to Noise Ratio / 信号対雑音比 (IHF)

..... 50 dB or more

Monitor Out Frequency Response / モニターアウト周波数帯域

Component video signal (U, C, R, T, K, A, B, G, E, L models)
..... 5 Hz to 60 MHz, -3 dB
D4-video signal (J model) 5 Hz to 60 MHz, -3 dB

■ FM Section / FM部

Tuning Range / 受信周波数範囲

U, C models 87.5 to 107.9 MHz
R, L models 87.5 to 108.0 / 87.50 to 108.00 MHz
T, K, A, B, G, E models 87.50 to 108.00 MHz
J model 76.0 to 90.0 MHz

50dB Quieting Sensitivity / 50 dB SN感度 (IHF) (1 kHz, 100 % Mod.)

Mono 2.8 μV (20.2 dBf)

Signal to Noise Ratio / 信号対雑音比 (IHF)

Mono / Stereo 73 dB / 70 dB

Harmonic Distortion / 歪率 (1 kHz)

Mono / Stereo 0.5 % / 0.5 %

Antenna Input / アンテナ入力 75 ohms unbalanced

■ AM Section / AM部

Tuning Range / 受信周波数範囲

U, C models 530 to 1,710 kHz
R, L models 530 to 1,710 / 531 to 1,611 kHz
T, K, A, B, G, E, J models 531 to 1,611 kHz

Antenna Input / アンテナ入力 Loop antenna

■ General / 総合

Power Supply / 電源電圧

U, C models AC 120 V, 60 Hz
R, L models AC 110-120/220-240 V, 50/60 Hz
T model AC 220 V, 50 Hz
K model AC 220 V, 60 Hz
A model AC 240 V, 50 Hz
B, G, E models AC 230 V, 50 Hz
J model AC 100 V, 50/60 Hz

Power Consumption / 消費電力

U, C models 240 W / 320 VA
R, T, K, A, B, G, E, L models 240 W
J model 180 W

Standby Power Consumption (reference data) /

待機時消費電力 (参考値)
U, C, T, K, A, B, G, E, J models 0.8 W

Maximum Power Consumption / 最大消費電力

(5 ch drive, 10 % THD)
R, L models 530 W

Dimensions / 寸法 (W x H x D)

..... 435 x 151 x 317.6 mm (17-1/8" x 5-15/16" x 12-1/2")

Weight / 質量

..... 8.0 kg (17 lbs. 10 oz.)

Finish / 仕上げ

[RX-V361]
Gold color T, L models
Black color U, C, R, A, G, E models
Silver color U, R, A, B, G, E models
Titanium color K, G, L models

[HTR-6030]

Gold color T model
Black color U, C, R, A, G models
Silver color U, C, R, T, K, A, G, E models

[DSP-AX361]

Silver color J model

Accessories / 付属品

Remote control x 1, Batteries (Manganese dry) x 2, FM antenna x 1, AM loop antenna x 1

* Specifications are subject to change without notice due to product improvements.

※ 参考仕様および外観は予告なく変更されることがあります。

U U.S.A. model C Canadian model
R General model T Chinese model
K Korean model A Australian model
B British model G European model
E South European model L Singapore model
J Japanese model



Manufactured under license from Dolby Laboratories.

“Dolby”, “Pro Logic”, and the double-D symbol are trademarks of Dolby Laboratories.

ドルビーラボラトリーズからの実施権に基づき製造されています。「ドルビー」、「PRO LOGIC」、およびダブルD記号は、ドルビーラボラトリーズの商標です。

SILENT™
CINEMA

“SILENT CINEMA” is a trademark of YAMAHA CORPORATION. 「サイレントシネマ™ SILENT CINEMA™」はヤマハ株式会社の登録商標です。



“DTS”, and “DTS Digital Surround” are registered trademarks of Digital Theater Systems, Inc. DTSおよびDTS Digital Surround はデジタルシアターシステムズの登録商標です。



The XM name and related logos are registered trademarks of XM Satellite Radio Inc.



Neural Surround™ name and related logos are trademarks owned by Neural Audio Corporation.



AACロゴマークはドルビーラボラトリーズの商標です。

• DIMENSIONS

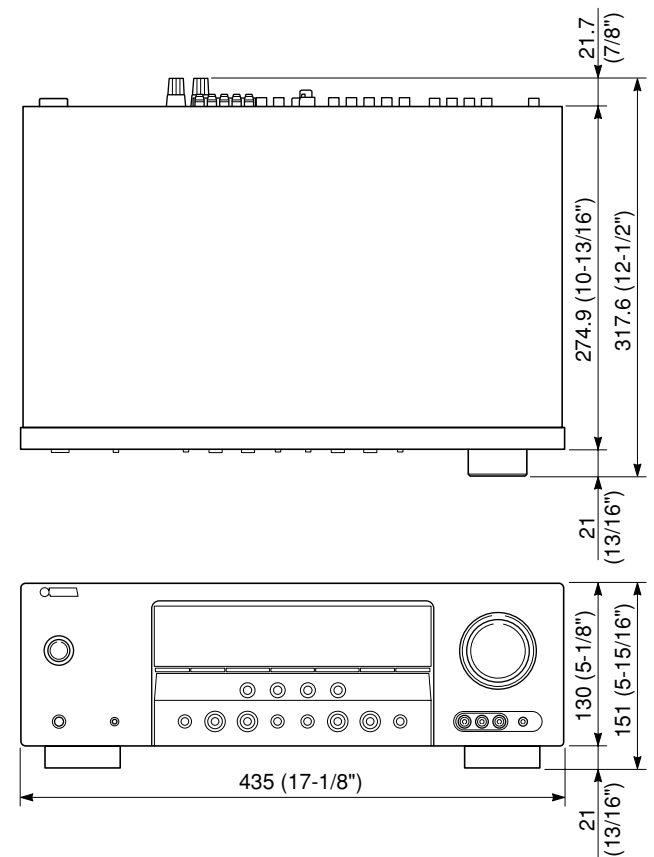

Unit: mm (inch)

単位: mm(インチ)

• **SCENE TEMPLATE**

SCENE name	Contents		Source	Program		Select (Default)	
				Mode	Sub-mode	U, C models	R, T, K, A, B, G, E, L, J models
DVD Viewing	DVD	Movie	DVD	STRAIGHT	–	<input type="radio"/> (SCENE 1)	<input type="radio"/>
DVD Movie Viewing			DVD	MOVIE THEATER	Movie Dramatic	<input type="radio"/>	<input type="radio"/> (SCENE 1)
DVD Live Viewing			DVD	MUSIC	Pop/Rock	<input type="radio"/>	<input type="radio"/>
DVR Viewing	DVR		DVR	MOVIE THEATER	Movie Dramatic	<input type="radio"/>	<input type="radio"/>
Music Disc Listening	DVD-Audio/SA-CD/CD	Music Disc	DVD	STEREO	2ch Stereo	<input type="radio"/>	<input type="radio"/> (SCENE 2)
Disc Listening			DVD	STEREO	5ch Stereo	<input type="radio"/> (SCENE 2)	<input type="radio"/>
CD Listening	CD	Music Disc	CD	STEREO	2ch Stereo	<input type="radio"/>	<input type="radio"/>
CD Music Listening			CD	STEREO	5ch Stereo	<input type="radio"/>	<input type="radio"/>
Radio Listening	TUNER/RADIO	FM/AM	FM/AM (TUNER)	MUSIC ENHANCER	5ch Stereo	<input type="radio"/> (SCENE 4)	<input type="radio"/> (SCENE 4)
XM Listening (U, C models)		XM	XM	MUSIC ENHANCER	5ch Stereo	<input type="radio"/>	–
TV Viewing	TV		DTV/CBL	STRAIGHT	–	<input type="radio"/> (SCENE 3)	<input type="radio"/> (SCENE 3)
TV Sports Viewing			DTV/CBL	ENTERTAINMENT	TV Sports	<input type="radio"/>	<input type="radio"/>
Game Playing	GAME		V-AUX	ENTERTAINMENT	Game	<input type="radio"/>	<input type="radio"/>

• **SOUND/SURROUND SELECT MENU**

Sound Field Parameters / 音場パラメーター

		DSP LEVEL MIN, [MID], MAX	MUSIC ENHANCER LOW, [HIGH]
STEREO	2ch Stereo		
	5ch Stereo		
MUSIC	Pop/Rock	<input type="radio"/>	
	Hall	<input type="radio"/>	
	Jazz	<input type="radio"/>	
ENTERTAIN	Game	<input type="radio"/>	
	TV Sports	<input type="radio"/>	
MOVIE	Movie Spacious	<input type="radio"/>	
	Movie Dramatic	<input type="radio"/>	
MUSIC ENHANCER	Music Enh. 2ch		<input type="radio"/>
	Music Enh. 5ch		<input type="radio"/>

Surround Decoders / サラウンド再生

		PANORAMA ON, [OFF]	DIMENSION -3, [STD], +3	CENTER WIDTH 0, 1, 2, [3], 4, 5, 6, 7
DECODING FORMAT	Dolby Digital			
	DTS			
	AAC (J model)			
POST DECODING FORMAT	Dolby Pro-Logic			
	Dolby Pro Logic II Music	<input type="radio"/>	<input type="radio"/>	<input type="radio"/>
	Dolby Pro Logic II Movie			
	Dolby Pro Logic II Game			
	Neural Surround (U, C models)			

• SET MENU TABLE / セットメニュー

CATEGORY	MAIN MENU	SUB MENU	SELECT MENU	VALUE [INITIAL]
BASIC SETUP			ROOM : M	S / [M] / L
			SUBWOOFER : YES	[YES] / NONE
			SPEAKERS : 5 spk	2 spk / 3 spk / 4 spk / [5 spk]
			SET / [CANCEL]	
			CHECK : Test Tone	
			CHECK OK? : YES	[YES] / NO
			FL *****	-10 dB to +10 dB [CENTER (0)], 1 dB step
			FR *****	
			C *****	
			SL *****	
			SR *****	
			SWFR *****	
			FRONT B : FRONT	[FRONT] / ZONE B
			CENTER SP : LARGE	SMALL / [LARGE]
			SUR. L/R SP : SML	NONE / [SML] / LRG
LFE/BASS OUT : BOTH	NONE / [SML] / LRG			
CROSS OVER : 80 Hz	SWFR / FRONT / [BOTH]			
SUBWOOFER PHASE : NORMAL	40 / 60 / [80] / 100 / 110 / 120 / 160 / 200 Hz			
FL *****	[NORMAL] / REVERSE			
FR *****	-10 dB to +10 dB [CENTER (0)], 1 dB step			
C *****				
SL *****				
SR *****				
SWFR *****				
UNIT : feet	feet / meters			
FRONT L : 10.0 ft	feet : 1.0 to 80.0 ft [10.0 ft], 0.5 ft step			
FRONT R : 10.0 ft				
CENTER : 10.0 ft				
SURR L : 10.0 ft				
SURR R : 10.0 ft				
SWFR : 10.0 ft				
FRONT L : 3.00 m	meters : 0.30 to 24.00 m [3.00 m], 0.10 m step			
FRONT R : 3.00 m				
CENTER : 3.00 m				
SURR L : 3.00 m				
SURR R : 3.00 m				
SWFR : 3.00 m				
TEST : > OFF ON	[OFF] / ON			
100 Hz -- -- 0 dB	-6 dB to +6 dB [0 dB], 0.5 dB step			
300 Hz -- -- 0 dB				
1 kHz -- -- 0 dB				
3 kHz -- -- 0 dB				
10 kHz -- -- 0 dB				
SP LFE : 0 dB	-20 dB to 0 dB [0 dB], 1 dB step			
HP LFE : 0 dB	-20 dB to 0 dB [0 dB], 1 dB step			
SP D. R. : MAX	MIN / STD / [MAX]			
HP D. R. : MAX	MIN / STD / [MAX]			
MUTING TYPE : FULL	[FULL] / -20 dB			
A. DELAY : 0 ms	[0 ms] to 160 ms, 1 ms step			
MAX VOL. : +16 dB	[+16 dB] / +10 dB / +5 dB / 0 dB / -5 dB / -10 dB / -15 dB / -20 dB / -25 dB / -30 dB			
INI. VOL. : OFF	[OFF] / -80 dB to +16 dB, 1 dB step			
DUAL MONO : MAIN	[MAIN] / SUB / ALL			
IN (1) COAXIAL : DVD	CD / MD-CD-R / DVD / DTV/CBL / V-AUX / DVR			
IN (2) OPTICAL : DVT/CBL	CD / MD-CD-R / DVD / DTV/CBL / V-AUX / DVR			
IN (3) OPTICAL : DVD	CD / MD-CD-R / DVD / DTV/CBL / V-AUX / DVR			
IN (1) COAXIAL : CD	[CD] / MD-CD-R / DVD / DTV/CBL / V-AUX / DVR			
IN (2) OPTICAL : DVT/CBL	CD / MD-CD-R / DVD / [DTV/CBL] / V-AUX / DVR			
IN (3) OPTICAL : DVD	CD / MD-CD-R / [DVD] / DTV/CBL / V-AUX / DVR			
	CD / MD-CD-R / DVD / DTV/CBL / V-AUX / DVR			
	Input is possible to 8 characters / 8文字まで入力可能			
	Input possible Character type / 入力可能文字 : Capital / 英大文字 A to Z,			
	Small / 英小文字 a to z, Figure / 数字 0 to 9, Space / 空白, Marks / 記号 # * + - / : < > ?			
	CD / MD-CD-R / TUNER / DVD / DTV/CBL / V-AUX / DVR / MULTI CH INPUT			
	-6.0 dB to +6.0 dB, [0.0 dB], 1 dB step			
	[AUTO] / LAST			
	[AUTO] / DTS / AAC (J model)			
	[LAST] / DVR / V-AUX / DTV/CBL / DVD			
	-4 to [0], 1 step			
	[CONT] / ONCE			
	[OFF] / ON			
	[AUTO] / LAST			
	[NO] / YES			
	[NONE] / 0 % to 100 %, 1 % step			
	[NONE] / 0 % to 100 % / Digital / --- / ???			
	xxx kHz			
	3/2/0.1 (Front/Surround/LFE) / 1+1			
	xxx kbps			
	DolbyD / DTS / PCM / None			
MANUAL SETUP	1 SOUND MENU	A) SPEAKER SET	ROOM	S / [M] / L
			SUBWOOFER	[YES] / NONE
			SPEAKERS	2 spk / 3 spk / 4 spk / [5 spk]
			SET / [CANCEL]	
			CHECK : Test Tone	
			CHECK OK? : YES	[YES] / NO
			FL *****	-10 dB to +10 dB [CENTER (0)], 1 dB step
			FR *****	
			C *****	
			SL *****	
			SR *****	
			SWFR *****	
			FRONT B : FRONT	[FRONT] / ZONE B
			CENTER SP : LARGE	SMALL / [LARGE]
			SUR. L/R SP : SML	NONE / [SML] / LRG
LFE/BASS OUT : BOTH	NONE / [SML] / LRG			
CROSS OVER : 80 Hz	SWFR / FRONT / [BOTH]			
SUBWOOFER PHASE : NORMAL	40 / 60 / [80] / 100 / 110 / 120 / 160 / 200 Hz			
FL *****	[NORMAL] / REVERSE			
FR *****	-10 dB to +10 dB [CENTER (0)], 1 dB step			
C *****				
SL *****				
SR *****				
SWFR *****				
UNIT : feet	feet / meters			
FRONT L : 10.0 ft	feet : 1.0 to 80.0 ft [10.0 ft], 0.5 ft step			
FRONT R : 10.0 ft				
CENTER : 10.0 ft				
SURR L : 10.0 ft				
SURR R : 10.0 ft				
SWFR : 10.0 ft				
FRONT L : 3.00 m	meters : 0.30 to 24.00 m [3.00 m], 0.10 m step			
FRONT R : 3.00 m				
CENTER : 3.00 m				
SURR L : 3.00 m				
SURR R : 3.00 m				
SWFR : 3.00 m				
TEST : > OFF ON	[OFF] / ON			
100 Hz -- -- 0 dB	-6 dB to +6 dB [0 dB], 0.5 dB step			
300 Hz -- -- 0 dB				
1 kHz -- -- 0 dB				
3 kHz -- -- 0 dB				
10 kHz -- -- 0 dB				
SP LFE : 0 dB	-20 dB to 0 dB [0 dB], 1 dB step			
HP LFE : 0 dB	-20 dB to 0 dB [0 dB], 1 dB step			
SP D. R. : MAX	MIN / STD / [MAX]			
HP D. R. : MAX	MIN / STD / [MAX]			
MUTING TYPE : FULL	[FULL] / -20 dB			
A. DELAY : 0 ms	[0 ms] to 160 ms, 1 ms step			
MAX VOL. : +16 dB	[+16 dB] / +10 dB / +5 dB / 0 dB / -5 dB / -10 dB / -15 dB / -20 dB / -25 dB / -30 dB			
INI. VOL. : OFF	[OFF] / -80 dB to +16 dB, 1 dB step			
DUAL MONO : MAIN	[MAIN] / SUB / ALL			
IN (1) COAXIAL : DVD	CD / MD-CD-R / DVD / DTV/CBL / V-AUX / DVR			
IN (2) OPTICAL : DVT/CBL	CD / MD-CD-R / DVD / DTV/CBL / V-AUX / DVR			
IN (3) OPTICAL : DVD	CD / MD-CD-R / DVD / DTV/CBL / V-AUX / DVR			
IN (1) COAXIAL : CD	[CD] / MD-CD-R / DVD / DTV/CBL / V-AUX / DVR			
IN (2) OPTICAL : DVT/CBL	CD / MD-CD-R / DVD / [DTV/CBL] / V-AUX / DVR			
IN (3) OPTICAL : DVD	CD / MD-CD-R / [DVD] / DTV/CBL / V-AUX / DVR			
	CD / MD-CD-R / DVD / DTV/CBL / V-AUX / DVR			
	Input is possible to 8 characters / 8文字まで入力可能			
	Input possible Character type / 入力可能文字 : Capital / 英大文字 A to Z,			
	Small / 英小文字 a to z, Figure / 数字 0 to 9, Space / 空白, Marks / 記号 # * + - / : < > ?			
	CD / MD-CD-R / TUNER / DVD / DTV/CBL / V-AUX / DVR / MULTI CH INPUT			
	-6.0 dB to +6.0 dB, [0.0 dB], 1 dB step			
	[AUTO] / LAST			
	[AUTO] / DTS / AAC (J model)			
	[LAST] / DVR / V-AUX / DTV/CBL / DVD			
	-4 to [0], 1 step			
	[CONT] / ONCE			
	[OFF] / ON			
	[AUTO] / LAST			
	[NO] / YES			
	[NONE] / 0 % to 100 %, 1 % step			
	[NONE] / 0 % to 100 % / Digital / --- / ???			
	xxx kHz			
	3/2/0.1 (Front/Surround/LFE) / 1+1			
	xxx kbps			
	DolbyD / DTS / PCM / None			
SIGNAL INFO	2 INPUT MENU	(U, C models)	CD / MD-CD-R / DVD / DTV/CBL / V-AUX / DVR	CD / MD-CD-R / DVD / DTV/CBL / V-AUX / DVR
3 OPTION MENU	(U, C models)	A) DISPLAY SET	DIMMER : 0	
			FL SCROLL : CONT	
			MEMORY GUARD : OFF	
			DEFAULT : AUTO	
			XM ANTENNA : NONE	
SIGNAL INFO	3 CHANNEL	(U, C models)	XM ANTENNA : NONE	
			Analog / PCM / DolbyD / DTS / AAC (J model) / Digital / --- / ???	
			xxx kHz	
			3/2/0.1 (Front/Surround/LFE) / 1+1	
			xxx kbps	
SIGNAL INFO	4 B.RATE (Bit rate)	(U, C models)	DolbyD / DTS / PCM / None	

INTERNAL VIEW

• Top view

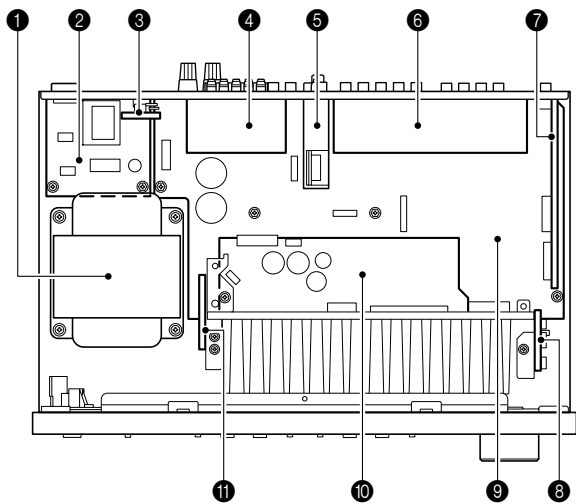

- ❶ Power Transformer
- ❷ OPERATION (3) P.C.B.
- ❸ OPERATION (5) P.C.B. (R, L models)
- ❹ MAIN (3) P.C.B.
- ❺ Tuner
- ❻ MAIN (2) P.C.B. (U, C, R, T, K, A, B, G, E, L models)
D-VIDEO P.C.B. (J model)
- ❼ DSP P.C.B.
- ❽ MAIN (4) P.C.B.
- ❾ MAIN (1) P.C.B.
- ❿ OPERATION (2) P.C.B.
- ⓫ OPERATION (11) P.C.B.
- ⓬ OPERATION (6) P.C.B.
- ⓭ OPERATION (10) P.C.B.
- ⓮ OPERATION (1) P.C.B.
- ⓯ OPERATION (7) P.C.B.

• Front view

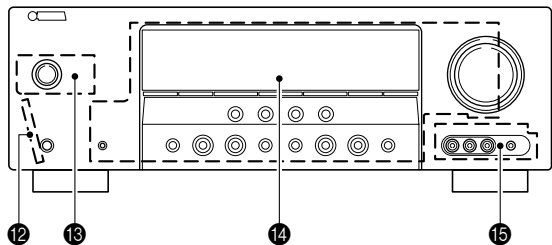

■ DISASSEMBLY PROCEDURES / 分解手順

(Remove parts in the order as numbered.)

Disconnect the power cable from the AC outlet.

(番号順に部品を取り外してください。)

AC電源コンセントから、電源コードを抜いてください。

1. Removal of Top Cover

- a. Remove 4 screws (①), 4 screws (②) and 1 screw (③). (Fig. 1)
- b. Slide the top cover rearward to remove it. (Fig. 1)

1. トップカバーの外し方

- a. ①のネジ4本、②のネジ4本、③のネジ1本を外します。(Fig. 1)
- b. トップカバーを後方へスライドさせ、取り外します。(Fig. 1)

2. Removal of Front Panel Unit

- a. Remove 6 screws (④). (Fig. 1)
- b. Remove CB192, CB235, CB261 and CB408. (Fig. 1)
- c. Remove hook and then remove the front panel unit. (Fig. 1)

2. フロントパネルユニットの外し方

- a. ④のネジ6本を外します。(Fig. 1)
- b. CB192、CB235、CB261、CB408を外します。(Fig. 1)
- c. フック1ヶ所を外し、フロントパネルユニットを取り外します。(Fig. 1)

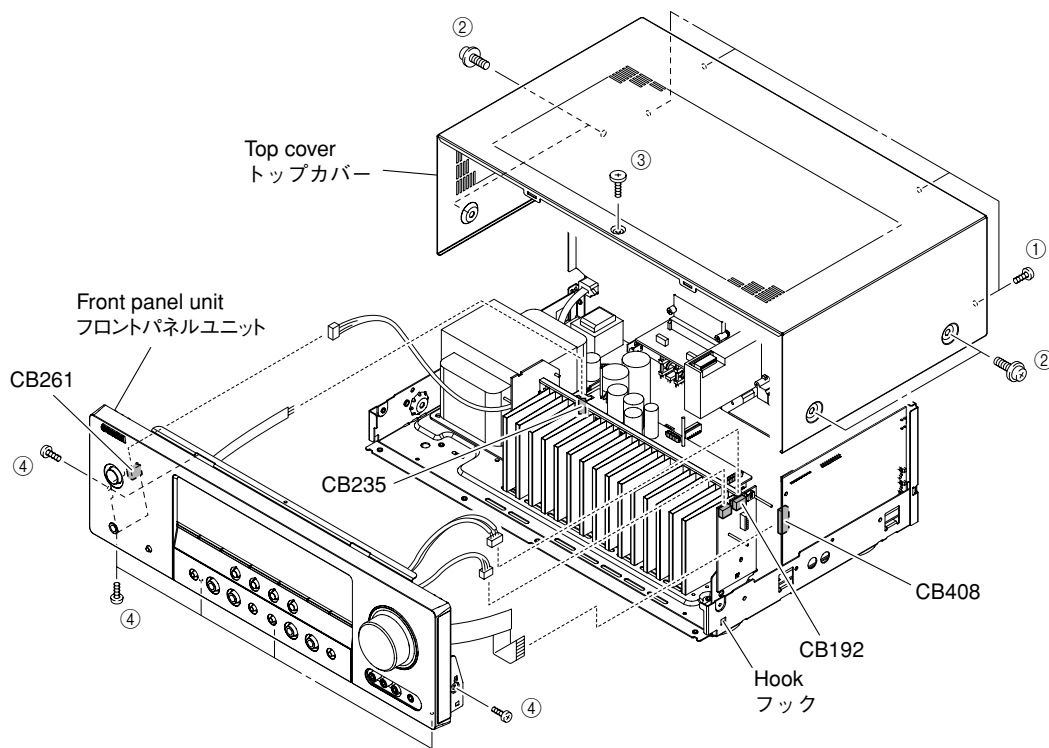

Fig. 1

3. Removal of MAIN (2) P.C.B.s

- a. Remove CB193 and CB181. (Fig. 2)
- b. Remove 7 screws (⑤). (Fig. 3)
- c. Remove MAIN (2) P.C.B.s. (Fig. 2)

3. D-VIDEO P.C.B.の外し方

- a. CB193、CB305を外します。(Fig. 2)
- b. ⑤のネジ7本を外します。(Fig. 3)
- c. D-VIDEO P.C.B.を取り外します。(Fig. 2)

4. Removal of DSP P.C.B.

- a. Remove 17 screws (⑥), 3 screws (⑦) and 2 screws (⑧) (R, L models). (Fig. 3)
- b. Remove cord stopper. (Fig. 2)
- c. Remove rear panel. (Fig. 2)
- d. Remove 1 screw (⑨). (Fig. 2)
- e. Remove CB512 and CB516. (Fig. 2)
- f. Remove the DSP P.C.B. which is connected directly to the MAIN (1) P.C.B. with connectors. (Fig. 2)

4. DSP P.C.B.の外し方

- a. ⑥のネジ17本、⑦のネジ3本を外します。(Fig. 3)
- b. コードストッパーを外します。(Fig. 2)
- c. リアパネルを取り外します。(Fig. 2)
- d. ⑨のネジ1本を外します。(Fig. 2)
- e. CB512、CB516を外します。(Fig. 2)
- f. DSP P.C.B.を取り外します。ただし、DSP P.C.B.は MAIN (1) P.C.B.と直接コネクター接続されています。(Fig. 2)

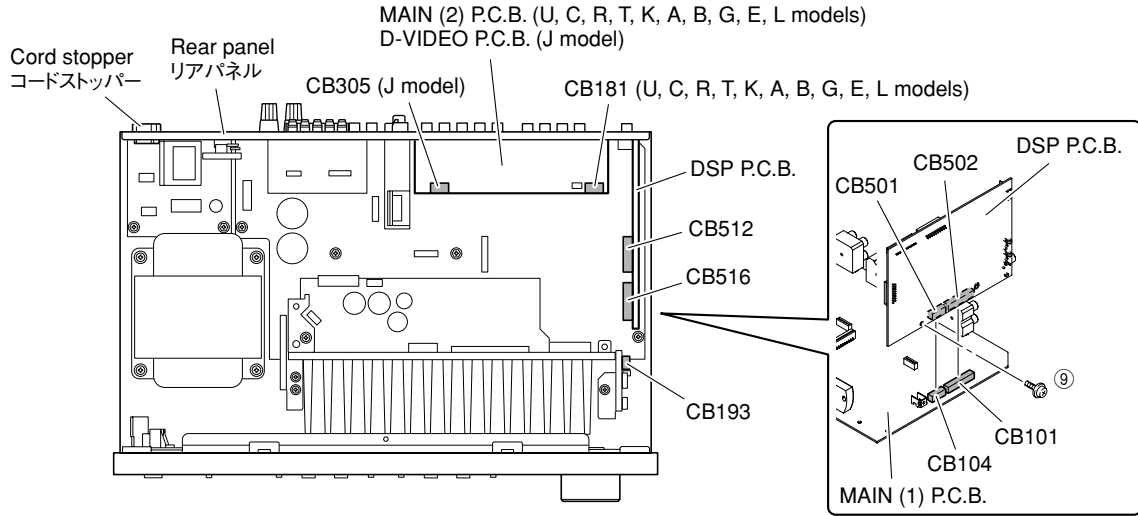
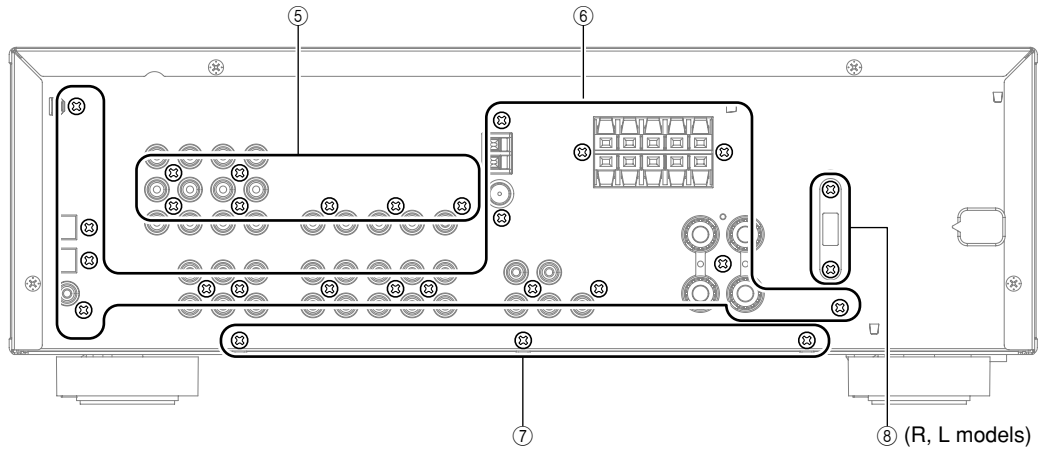

Fig. 2

U, C, R, T, K, A, B, G, E, L models



J model

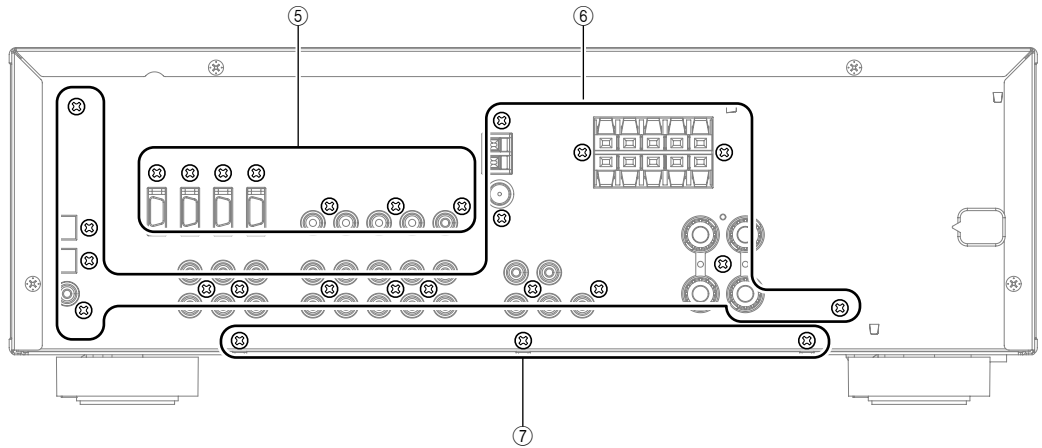

Fig. 3

When checking the P.C.B.

- a. Remove the Top cover. (Fig. 1)
 - b. Remove 3 screws (⑦). (Fig. 3)
 - c. Remove 5 screws (⑩) and 4 screws (⑪). (Fig. 4)
 - d. Place the P.C.B. upright. (Fig. 5)
 - e. The rear panel and P.C.B. removed from the chassis does not work because its grounding is loose.
Be sure to connect the ground of heat sink, rear panel and MAIN (1) P.C.B. (G103, G104, G105 and ST101) to the chassis with a ground lead or the like. (Fig. 5)
- Be sure to use the extension cable for servicing for the following section. (Fig. 6)
DSP P.C.B. CB408 OPERATION (1) P.C.B. CB202: V2854400 (17P, 300mm)

P.C.B.をチェックする場合

- a. トップカバーを外します。(Fig. 1)
 - b. ⑦のネジ3本を外します。(Fig. 3)
 - c. ⑩のネジ5本、⑪のネジ4本を外します。(Fig. 4)
 - d. P.C.B.を立ち上げて置きます。(Fig. 5)
 - e. シャーシから外したリアパネルおよびP.C.B.はアースが浮いて動作しませんので、ヒートシンク、リアパネルおよびMAIN(1)P.C.B.のG103、G104、G105、ST101のアースをリード線等でシャーシに接続してください。(Fig. 5)
- 次の区間は、サービス用延長ケーブルを使用してください。(Fig. 6)
DSP P.C.B. CB408 OPERATION(1)P.C.B. CB202 : V2854400 (17P、300mm)

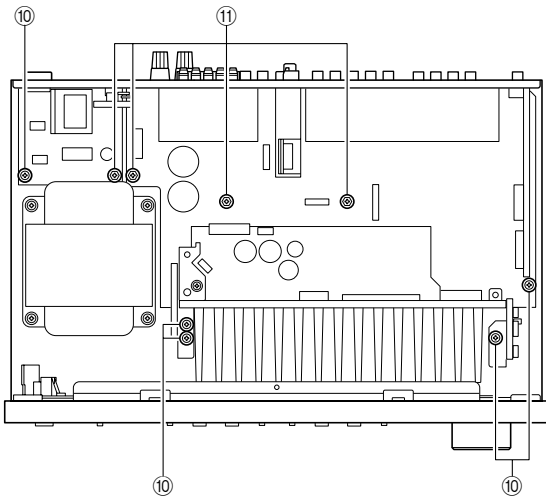

Fig. 4

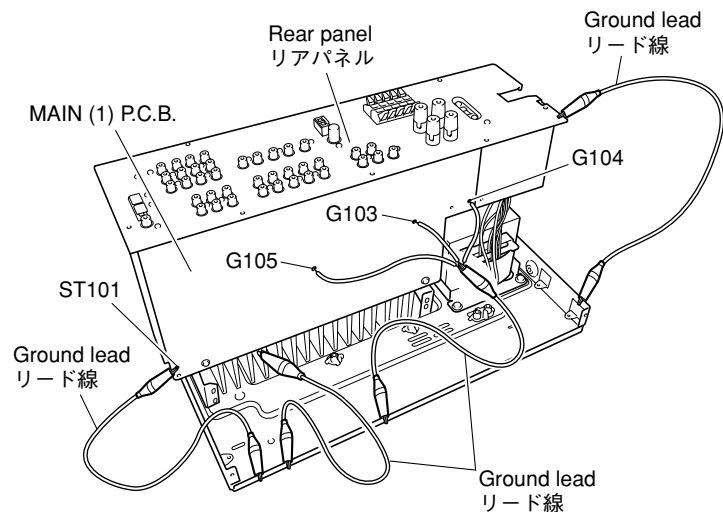

Fig. 5

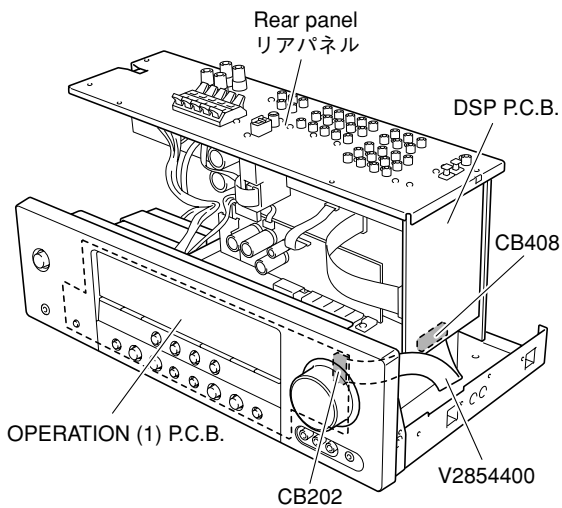

Fig. 6

■ UPDATING FIRMWARE / ファームウェアの書き込み

After replacing the following parts with the replacement part, be sure to write the latest firmware.

- DSP P.C.B.
- IC201 (DSP P.C.B.)

● Required Tools

- DVD or CD player (with DIGITAL OUTPUT (OPTICAL or COAXIAL) terminal)
- Optical cable (when OPTICAL terminal is used)
- Digital audio pin cable (when COAXIAL terminal is used)
- Firmware CD
 - * To make the firmware CD, download the latest firmware from the specified download source to PC.

● Operation Procedures

1. Connect the main unit and DVD/CD player as shown below. (Fig. 1)

下記部品をサービス部品に交換した場合、最新のファームウェアの書き込みを行ってください。

- DSP P.C.B.
- IC201 (DSP P.C.B.)

● 必要なツール

- DVDまたはCDプレーヤー (DIGITAL OUTPUT (OPTICALまたはCOAXIAL)端子付き)
- 光ファイバーケーブル (OPTICAL端子使用時)
- デジタル音声ピンケーブル (COAXIAL端子使用時)
- ファームウェアCD
 - ※ ファームウェアCDは、PCへ最新のファームウェアを指定のダウンロード先からダウンロードして制作してください。

● 操作方法

1. 本機とDVD/CDプレーヤーを下記のように接続します。(Fig. 1)

Example of OPTICAL terminal / OPTICAL端子使用例

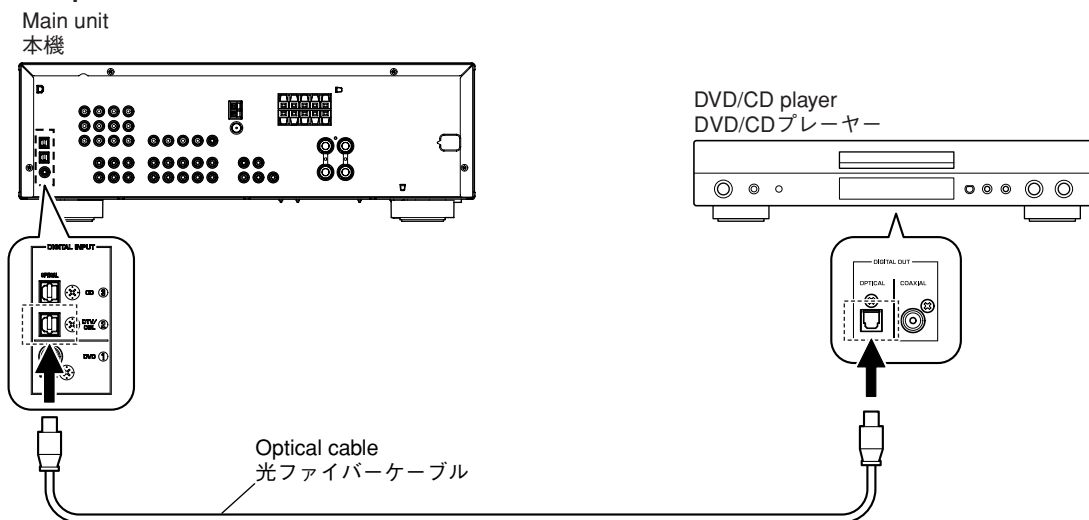

Example of COAXIAL terminal / COAXIAL端子使用例

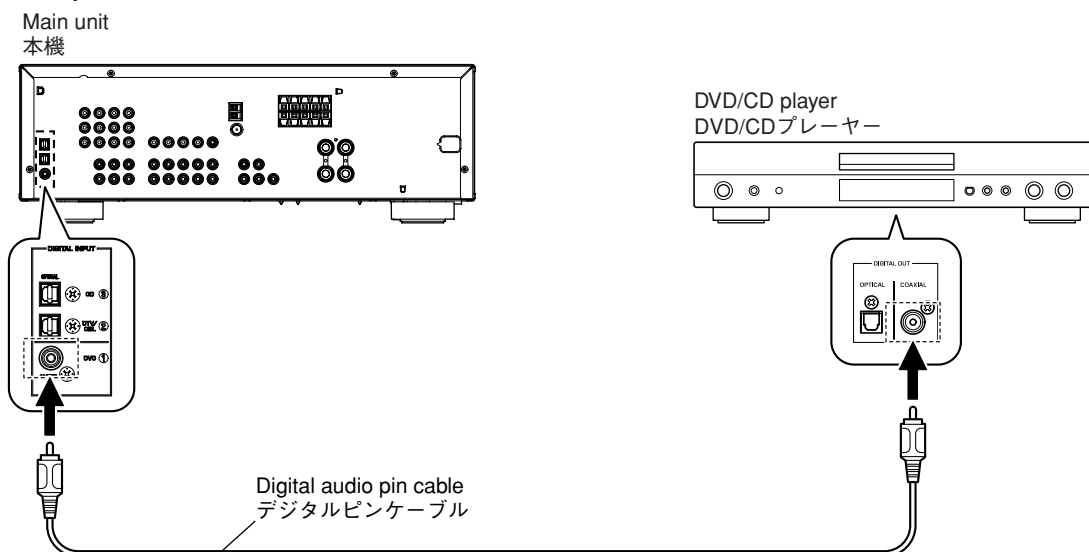

Fig. 1

- While pressing the "STANDBY/ON" key and "SPEAKERS A/B/OFF" key of the main unit simultaneously, connect the power cable of the main unit to the AC outlet. (Fig. 2)
The FIRMWARE UPDATE mode will then be activated and "SPDIF Upgrade" is displayed. (Fig. 2)

- 本機の"STANDBY/ON"キーと、"SPEAKERS A/B/OFF"キーを押しながら、本機の電源コードをACコンセントに接続します。(Fig. 2)
FIRMWARE UPDATEモードが起動し、"SPDIF Upgrade"が表示されます。(Fig. 2)

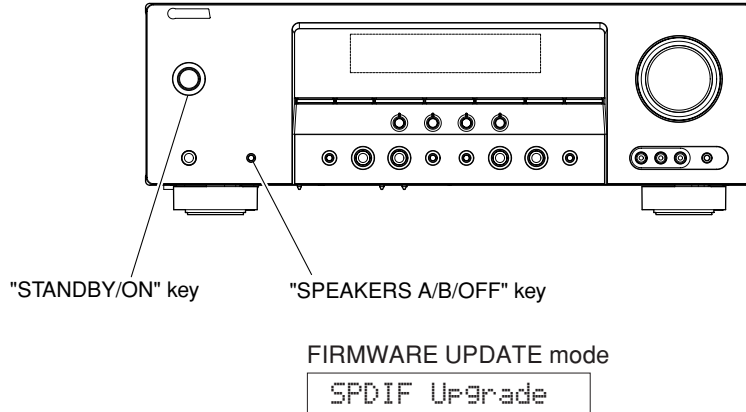

Fig. 2

- Connect the power cable of DVD/CD player to the AC outlet.
- Press the "STANDBY/ON" key of the DVD/CD player.
- Press the "EJECT" key of the DVD/CD player to open the tray.
- Put the firmware CD on the tray and close the tray.
- Press the "PLAY" key of the DVD/CD player. Then writing of the firmware is started. (Fig. 3)
- When writing of the firmware is completed, "Upgrade OK", "Please..." and "Turn off!!" are displayed repeatedly. (Fig. 3)

- DVD/CDプレーヤーの電源コードをACコンセントに接続します。
- DVD/CDプレーヤーの"STANDBY/ON"キーを押します。
- DVD/CDプレーヤーの"EJECT"キーを押し、トレイを開きます。
- ファームウェアCDをトレイに載せ、トレイを閉じます。
- DVD/CDプレーヤーの"PLAY"キーを押します。ファームウェアの書き込みが開始されます。(Fig. 3)
- ファームウェアの書き込み完了後、"Upgrade OK"、"Please..."、"Turn off!!"が繰り返し表示されます。(Fig. 3)

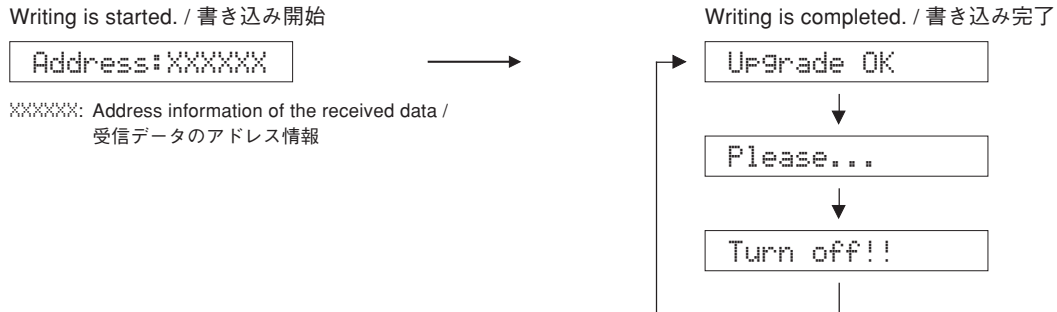

Fig. 3

- * When the version of the firmware to be written is the same as the one existing in the main unit, “Same Version”, “Please...” and “Turn off!!” are displayed repeatedly. (Upgrading is not necessary.)

If the display remains unchanged for more than 10 seconds after starting the firmware CD play procedure, perform the firmware CD play procedure again from the beginning.

If “FILE CORRUPTED” is displayed after “Address:XXXXXX”, check to make sure that the written data is not corrupted and perform Steps 1 to 8 of “Operation Procedures” again.

If “Upgrade Failed” is displayed, perform Steps 1 to 8 of “Operation Procedures” again.

9. Press the “STOP” key of the DVD/CD player.
10. Press the “EJECT” key of the DVD/CD player to open the tray.
11. Remove the firmware CD from the tray and close the tray.
12. Turn off the power of the DVD/CD player and disconnect the power cable from the AC outlet.
13. Turn off the power by pressing the “STANDBY/ON” key of the main unit.

● Confirmation of firmware version and checksum

Confirm that the firmware version and checksum value is updated successfully with the DIAG function.

For more information, refer to “SELF DIAGNOSIS FUNCTION (DIAG)”.

- * When the displayed firmware version and checksum are different from written firmware version and checksum, follow the steps from 1 to 13 of “Operation Procedures” again.

- ※ 本機に既存のファームウェアと、書き込もうとしているファームウェアのバージョンが同じ場合、“Same Version”、“Please...”、“Turn off!!”の表示が繰り返されます。(バージョンアップの必要はありません。)

ファームウェアCDの再生開始後、10秒以上経過してもディスプレイ表示が変わらない場合、ファームウェアCDの再生を最初からやり直してください。

“Address:XXXXXX”の後に、“FILE CORRUPTED”が表示された場合、書き込みデータが破損していないかを確認し、“操作方法”の1から8までをもう一度やり直してください。

“Upgrade Failed”が表示された場合、“操作方法”の1から8までをもう一度やり直してください。

9. DVD/CDプレーヤーの“STOP”キーを押します。
10. DVD/CDプレーヤーの“EJECT”キーを押し、トレイを開きます。
11. ファームウェアCDをトレイから外し、トレイを閉じます。
12. DVD/CDプレーヤーの電源を切り、電源コードをACコンセントから抜きます。
13. 本機の“STANDBY/ON”キーを押して電源を切ります。

● ファームウェアバージョンおよびチェックサムの確認

ダイアグメニューでファームウェアのバージョンおよびチェックサムが正しく更新されたことを確認します。

ダイアグメニューの詳細は「自己診断(ダイアグ)」を参照してください。

- ※ 表示されたファームウェアのバージョンおよびチェックサムが、書き込んだファームウェアのバージョンおよびチェックサムと異なる場合、“操作方法”の1から13までをもう一度やり直してください。

■ SELF DIAGNOSIS FUNCTION (DIAG)／自己診断機能 (ダイアグ)

This unit has self diagnosis functions that are intended for inspection, measurement and location of faulty point.

There are 18 DIAG menu items, each of which has sub-menu items.

Listed in the table below are menu items and sub-menu items.

Note that not all menu items listed will apply to the models covered in this service manual.

本機には、検査、測定、不良個所の発見を目的にした自己診断機能(ダイアグ)があります。

ダイアグメニューは18個あり、そのそれぞれにサブメニューがあります。

下表はダイアグメニュー一覧です。

下表の全ダイアグメニュー項目が、このサービスマニュアル記載のモデルに適用されるとは限りません。

No.	DIAG menu	Sub-menu
1	BYPASS	ANALOG BYPASS
		DSP BYPASS
2	AUDIO CHECK	AUDIO CHECK
3	SPEAKERS SET	FRNT : SML 0dB
		CENTER : NONE
		LFE/B : FRNT
		TONE : MAX
		TONE : MIN
4	6CH-INPUT	6ch INPUT 6-ohm
		6ch INPUT 8-ohm
		LIM : , PLDET : , THM :
5	MIC CHECK	MIC CHECK
6	FL/OSD CHECK	VFD CHECK
		VFD DISP OFF
		VFD DISP ALL
		VFD DIMMER
		CHECK PATTERN
7	TEST TONE	TEST ALL
		TEST FRNT L
		TEST CENTER
		TEST FRNT R
		TEST SURR R
		TEST SURR L
		TEST LFE
8	FACTORY PRESET	PRESET INHI
		PRESET RSRV
9	AD DATA CHECK	PD : , PV :
		TH : , PL :
		PI : , DE :
		K0 : , K1 :
10	XM STATUS (U, C models)	1k -1dB/44
		1k -61dB/44
		Mute/44
		XM Tone/44
		ISO Tone/44
		1k -1dB/32
		1k -61dB/32
		Mute/32
		XM Tone/32
		ISO Tone/32
		Bus Power : OFF
		11
DOCK ignore		
12	USB (Not applied to these models.)	USB 1
		USB 2
13	DAB (Not applied to these models.)	DAB 1
		DAB 2
		DAB 3

No.	DIAG menu	Sub-menu
14	IF STATUS (Not applied to these models.)	IF 1 IF 2 IF 3 IF 4 IF 5 IF 6 IF 7 IF 8 IF 9 IF 10 IF 11 IF 12 IF 13 IF 14 IF 15 IF 16 IF 17
15	PROTECTION	PRD L : PRD H : PRV L : PRV H : THM : PLD8H : PLD8L : PLD6H : PLD6L : PRI : PDET :
16	PROTECTION HISTORY	History 1 History 2 History 3 History 4
17	SOFT SWITCH	SW MODE MODEL DESTINATION TUNER DESTINATION VIDEO FORMAT AAC OSD YPAO RDS XM DAB USB DOCK (iPod)
18	ROM VER/SUM	VERSION ALL CHECKSUM PROGRAM CHECKSUM SPI CHECKSUM SPD CHECKSUM XM VERSION DAB VERSION FlashROM TEST SDRAM TEST EEPROM TEST

● Starting DIAG

Press the “STANDBY/ON” key while simultaneously pressing those two keys of the main unit as indicated in the figure below.

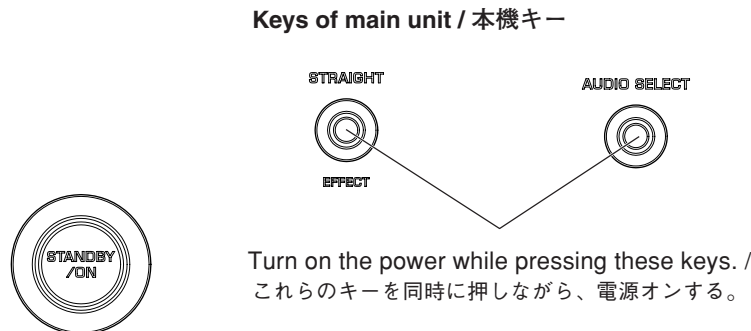

● ダイアグの起動

本体の下図に示すキーを同時に押しながら“STANDBY/ON”キーを押すと、ダイアグが起動します。

● Starting DIAG in the protection cancel mode

If the protection function works and causes hindrance to trouble diagnosis, cancel the protection function as described below, and it will be possible to enter the DIAG mode. (The protection functions other than the excess current detect function will be disabled.)

Press the “STANDBY/ON” key while simultaneously pressing those two keys indicated in the figure above. At this time, keep pressing those two keys for 3 seconds or longer.

In this mode, the [SLEEP] segment of the FL display of the main unit flashes to indicate that the mode is DIAG mode with the protection functions disabled.

● プロテクション解除モードでの起動

プロテクションが動作することにより、故障箇所の診断に支障をきたすような場合は、次の方法によりプロテクションを解除した状態でダイアグモードに入ることができます。(過電流検出以外のプロテクション動作を解除する)

上図のキーを同時に押しながら“STANDBY/ON”キーを押します。このとき、上図のキーを3秒以上押し続けてください。

このモードでは本体FLの「SLEEP」セグメントが点滅し、プロテクションを解除した状態でのダイアグモードであることを知らせます。

CAUTION!

Using this product with the protection function disabled may cause damage to the main unit. Use special care for this point when using this mode.

注意!

プロテクション解除モードでの起動は、危険な状態でもプロテクションが作動しないため、動作させると本機を破壊することがあります。このモードを使用する場合は十分注意してください。

● Canceling DIAG

1. Before canceling DIAG, execute setting for FACTORY PRESET of DIAG menu No.8 (Memory initialization inhibited or Memory initialized).

* In order to keep the user memory stored, be sure to select PRESET INHIBITED (Memory initialization inhibited).

2. Turn off the power by pressing the “STANDBY/ON” key of the main unit.

● ダイアグの解除

1. ダイアグを解除する前に、ダイアグメニューNo. 8 FACTORY PRESET(メモリーの初期化禁止/またはメモリーの初期化)の設定をします。

※ ユーザーメモリーを保持したい場合は、必ず PRESET INHIBITED(メモリー初期化禁止)を選択してください。

2. 本機の“STANDBY/ON”キーを押し、電源オフします。

● Display provided when DIAG started

On the FL display of the main unit, an opening message (including the protection history) appears for a few seconds followed by the DIAG menu display (1. ANALOG BYPASS).

● ダイアグ起動時の表示

本機のFLディスプレイには、オープニング(プロテクション履歴)が表示され、数秒後にダイアグメニュー表示(1. ANALOG BYPASS)となります。

When there is no history of protection function:

Opening message / オープニング表示

プロテクション履歴が無い場合:

DIAG menu display / ダイアグメニュー表示

When there is no protection history
プロテクション履歴が無い場合

After a few seconds / 数秒後

NO PROTECTION

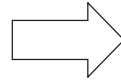

1. ANALOG BYPASS

When there is a history of protection function:**When there is a history of protection function due to excess current**

プロテクション履歴がある場合:

過電流によるプロテクション履歴がある場合

PRI PRT:xxx

AD value when the protection function is working
プロテクション動作時のA/D値**Cause:** An excessive current flowed through the power amplifier.**Supplementary information:**

As current of the power amplifier is detected, the abnormal channel can be identified by checking the current detect transistor.

Turning on the power without correcting the abnormality will cause the protection function to work immediately and the power supply will instantly be shut off.

原因: パワーアンプに過電流が流れた。**補足:** パワーアンプの電流を検出していますので、電流検出トランジスタをチェックすれば異常チャンネルが特定できます。異常状態のまま電源オンすると、瞬時にプロテクションがかかり、すぐに電源が切れます。**Note)**

- Applying the power to the main unit without correcting the abnormality can be dangerous and cause additional circuit damage. To avoid this, if "PRI" and "PRD" protection function has been activated 3 times continuously, the power will not turn on even when the "STANDBY/ON" key is pressed. In order to turn on the power again, disconnect the power cable of the main unit from the AC outlet once and then reconnect it again.
- The output transistors in each amplifier channel should be checked for damage before applying power of the main unit.
- Amplifier current should be monitored by measuring across the emitter resistors for each channel.

注意!

- 異常状態のまま本機の電源を入れると、危険な状態になり、さらに回路が損傷を受ける原因になります。そのため連続して"PRI"および"PRD"プロテクションが働いた場合、3回目から"STANDBY/ON"キーを押しても電源が入らなくなります。再度電源を入れる場合、一度本機の電源コードをAC電源コンセントから抜いて接続し直してください。
- 本機の電源をいれる前に、各アンプのチャンネル内の出力トランジスタに損傷がないかチェックしてください。
- アンプの電流は、各チャンネルのエミッターの抵抗器間で測定することによりモニターしてください。

When there is a history of protection function due to abnormal DC output

DC出力異常によるプロテクション履歴がある場合

PRD PRT:xxx

AD value when the protection function is working
プロテクション動作時のA/D値**Cause:** DC output of the power amplifier is abnormal.**Supplementary information:**

The protection function worked due to a DC voltage appearing at the speaker terminal.

A cause could be a defect in the amplifier.

If the power is turned on with the abnormality unsolved, the protection function works in about 3 seconds to turn off the power.

原因: パワーアンプのDC出力が異常。**補足:** アンプの故障でスピーカー端子に直流電圧が掛かるなどが原因で、プロテクションが働いたことを示します。異常状態のままパワーオンすると、約3秒後にプロテクションが掛かり、電源が切れます。

When there is a history of protection function due to abnormal voltage in the power supply section

電源部の電圧異常によるプロテクション履歴がある場合

PRV PRT:xxxx

AD value when the protection function is working
プロテクション動作時のA/D値

Cause: The voltage in the power supply section is abnormal.

原因: 電源部の電圧が異常。

Supplementary information:

The protection function worked due to a defect or overload in the power supply.
If the power is turned on with the abnormality unsolved, the protection function works in about 1 second to turn off the power.

補足: 電源電圧による原因で、プロテクションが働いたことを示します。
異常状態のままパワーオンすると、約1秒後にプロテクションが掛かり、電源が切れません。

When there is a history of protection function due to excessive heat sink temperature

ヒートシンクの異常温度によるプロテクション履歴がある場合

THM PRT:xxxx

AD value when the protection function is working
プロテクション動作時のA/D値

Cause: The temperature of the heat sink is excessive.

原因: ヒートシンクの温度が異常。

Supplementary information:

The protection function worked due to the temperature limit being exceeded.
Causes could be poor ventilation or a defect related to the thermal sensor.

補足: 温度制限を越えた原因で、プロテクションが働いたことを示します。

If the power is turned on with the abnormality unsolved, the protection function works in about 1 second to turn off the power.

異常状態のままパワーオンすると、約1秒後にプロテクションが掛かり、電源が切れません。

For detection of each protection function, refer to DIAG menu described later.

各プロテクションの検出に関しては、後述のダイアグメニューを参照してください。

History of protection function

When the protection function has worked, its history is stored in memory with a backup.

Even if no abnormality is noted while servicing the unit, an abnormality which has occurred previously can be defined as long as the backup data has been stored.

The history of the protection function is cleared when DIAG is cancelled by selecting PRESET RESERVED (Memory initialized) of DIAG menu No. 8 or when the backup data is erased.

プロテクションの履歴

プロテクションが働いた場合、履歴をバックアップして記憶しています。

サービスのときに異常が認められなくても、バックアップが残っていれば、お客様のところで起きた異常を区別できます。

ダイアグメニューNo. 8 PRESET RESERVED(メモリーの初期化)を選んでダイアグを解除した場合または、バックアップが消えた場合にプロテクションの履歴はクリアされます。

● Operation procedure of DIAG menu and Sub-menu

There are 18 menu items, each of having sub-menu items.

DIAG menu selection:

Select the menu using “>” (forward) and “<” (reverse) keys of PROGRAM.

Sub-menu selection:

Select the sub-menu using “SCENE 2” (forward) and “SCENE 1” (Reverse) keys.

● ダイアグメニューとサブメニューの操作

ダイアグにはNo. 1～18のメニューがあり、それぞれにサブメニューがあります。

ダイアグメニューの選択：

“PROGRAM >” (順送り)、“PROGRAM <” (逆送り) キーで選択します。

サブメニューの選択：

“SCENE 2” (順送り)、“SCENE 1” (逆送り) キーで選択します。

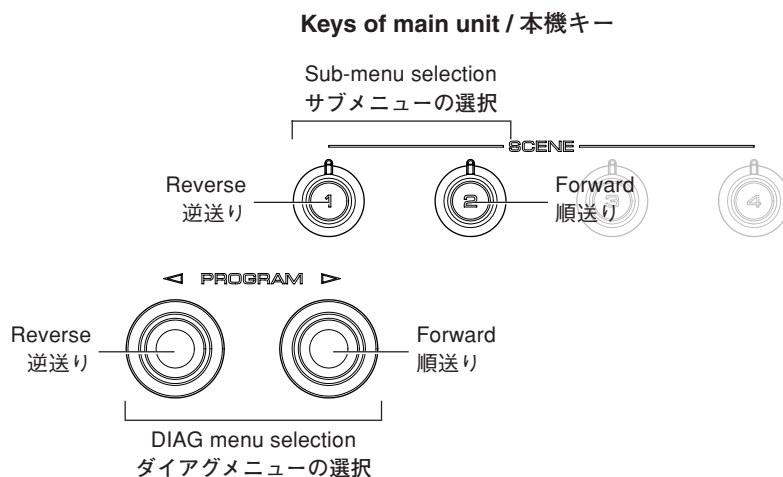

● Functions in DIAG mode

In addition to the DIAG menu items, functions as listed below are available.

- Power on/off
- Master volume
- Muting
- Speakers A/B/OFF
- Input selection
- Audio select
- Tone control

* Functions related to the tuner and the set menu are not available.

● ダイアグ中の機能

ダイアグメニューの他に、以下の機能が動作します。

- パワーオン/オフ
- マスターボリューム
- ミューティング
- スピーカーA/B/OFF
- インプット切り換え
- オーディオセレクト
- トーンコントロール

※ チューナー関連、セットメニュー関連は機能しません。

● Initial settings used to start DIAG

The following initial settings are used when starting DIAG.

When DIAG is canceled, these settings are restored to those before starting DIAG.

- Master volume: -20 dB
- Input: DVD (MULTI CHANNEL INPUT OFF)
- Effect level: 0 dB
- DIAG menu: 1. ANALOG BYPASS

● ダイアグ開始時の初期設定

ダイアグ開始時に以下のような設定になります。ダイアグ解除時にはダイアグ開始前の状態に戻ります。

- マスターボリューム：-20 dB
- インプット：DVD (マルチチャンネルインプットオフ)
- エフェクトレベル：0 dB
- ダイアグメニュー：1. ANALOG BYPASS

● Details of DIAG menu

1. BYPASS

Using the sub-menu, it is possible to select ANALOG BYPASS output or DSP BYPASS output.

ANALOG BYPASS

The analog input sound signal is output to FRONT L/R with EFFECT OFF.

1. ANALOG BYPASS

INPUT: DVD ANALOG

SPEAKER OUT: 1 kHz, SUBWOOFER OUTPUT: 50 Hz

Input level	Volume	SPEAKER OUT			SUBWOOFER OUTPUT
		FRONT	CENTER	SURROUND	
Both ch, -20 dBm	+6.0 dB	+11.5 dBm	-∞	-∞	-∞

DSP BYPASS

The digital input sound signal is output to FRONT L/R with EFFECT OFF.

1. DSP BYPASS

INPUT: DVD ANALOG

SPEAKER OUT: 1 kHz, SUBWOOFER OUTPUT: 50 Hz

Input level	Volume	SPEAKER OUT			SUBWOOFER OUTPUT
		FRONT	CENTER	SURROUND	
Both ch, -20 dBm	+6.0 dB	+11.5 dBm	-∞	-∞	-∞

2. AUDIO CHECK

The input sound signal is output.

* When the inputted sound signal is 2 ch L/R, it is distributed as follows when output.

L ch: FRONT L, CENTER, SURROUND L, LFE (L ch +10 dB)

R ch: SURROUND R

2. AUDIO CHECK

2. AUDIO CHECK

入力された音声信号を出力します。

※ 入力された音声信号が2 ch L/Rの場合は、下記のように振り分け出力します。

L ch: FRONT L, CENTER、SURROUND L、LFE(L ch +10 dB)

R ch: SURROUND R

INPUT: DVD ANALOG

SPEAKER OUT: 1 kHz, SUBWOOFER OUTPUT: 50 Hz

Input level	Volume	SPEAKER OUT			SUBWOOFER OUTPUT
		FRONT	CENTER	SURROUND	
Both ch, -20 dBm	+6.0 dB	+11.5 dBm	+11.5 dBm	+11.5 dBm	0 dBm

3. SPEAKER SET

The analog switch settings for each sub-menu are as shown in the table below.

FRONT : SML 0dB	SMALL	LARGE	LARGE	SWFR
CENTER : NONE	LARGE	NONE	LARGE	SWFR
LFE/B : FRNT	LARGE	SMALL	SMALL	FRONT
TONE : MAX	LARGE	LARGE	LARGE	SWFR
TONE : MIN	LARGE	LARGE	LARGE	SWFR

- LARGE:** This mode is used for a speaker with high bass reproduction performance (a large unit). Full bandwidth signals are output.
- SMALL:** This mode is used for a speaker with low bass reproduction performance (a small unit). The signals of 90 Hz or less are mixed into the channel specified by LFE/BASS.
- NONE:** This mode is used for no center speaker. The center content is reduced by 3 dB and distributed to FRONT L/R.
- SWFR:** LFE of 5.1 ch signal or LFE/BASS lower than 90 Hz is output through SUBWOOFER OUT.
- FRONT:** LFE of 5.1 ch signal or LFE/BASS lower than 90 Hz is distributed to FRONT L/R.

3. SPEAKER SET

各サブメニューにおけるアナログスイッチの設定は以下の通りです。

- LARGE :** 低音再生能力の高い(ユニットの大きい)スピーカーを使用するモードです。全帯域が出力されます。
- SMALL :** 低音再生能力の低い(ユニットの小さい)スピーカーを使用するモードです。90 Hz以下がLFE/BASSで指定したチャンネルにミックスされます。
- NONE :** センタースピーカーを使用しないモードです。センター成分は-3 dBされて、FRONT L/Rに振り分けられます。
- SWFR :** 5.1 ch信号のLFEまたは90 Hz以下のLFE/BASSがSUBWOOFER OUTに出力されます。
- FRONT :** 5.1 ch信号のLFEまたは90 Hz以下のLFE/BASSをFRONT L/Rに振り分けます。

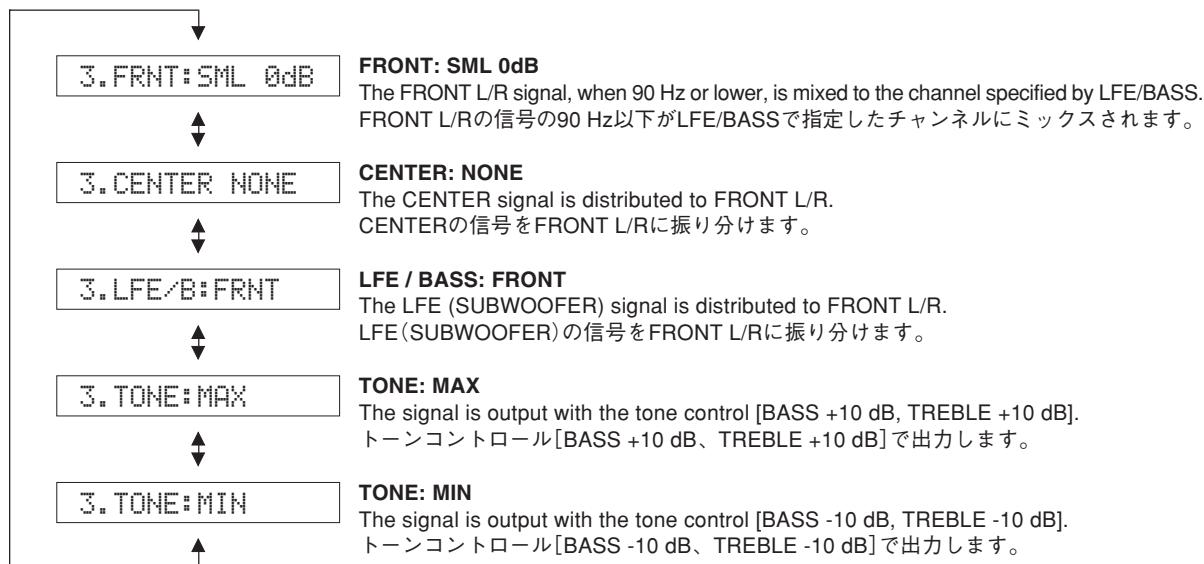

INPUT: DVD ANALOG

SPEAKER OUT: 1 kHz, SUBWOOFER OUTPUT: 50 Hz

Sub-menu	Input level	Volume	SPEAKER OUT			SUBWOOFER OUTPUT
			FRONT	CENTER	SURROUND	
FRONT : SML 0dB	Both ch, -20 dBm	+6.0 dB	+11.5 dBm	-∞	-∞	-3.5 dBm
CENTER : NONE	Both ch, -20 dBm	+6.0 dB	+11.5 dBm	-∞	-∞	-∞
LFE/B : FRNT	Both ch, -20 dBm	+6.0 dB	+11.5 dBm	-∞	-∞	-∞
TONE : MAX	Both ch, -20 dBm	+6.0 dB	+14.5 dBm	-∞	-∞	-∞
TONE : MIN	Both ch, -20 dBm	+6.0 dB	+8.5 dBm	-∞	-∞	-∞

4. 6CH INPUT

The input source [MULTI CHANNEL INPUT] is selected.
It is possible to select the 6-ohm/8-ohm by using the sub-menu.

6 ch INPUT 6-ohm

4.6ch INPUT 6Ω

INPUT: MULTI CH INPUT
SPEAKER OUT: 1 kHz, SUBWOOFER OUTPUT: 50 Hz

Sub-menu	Input level	Volume	SPEAKER OUT			SUBWOOFER OUTPUT
			FRONT	CENTER	SURROUND	
6 ch INPUT 6-ohm	Both ch, -20 dBm	+6.0 dB	+11.5 dBm	+11.5 dBm	+11.5 dBm	-3.5 dBm

6 ch INPUT 8-ohm

4.6ch INPUT 8Ω

INPUT: MULTI CH INPUT
SPEAKER OUT: 1 kHz, SUBWOOFER OUTPUT: 50 Hz

Sub-menu	Input level	Volume	SPEAKER OUT			SUBWOOFER OUTPUT
			FRONT	CENTER	SURROUND	
6 ch INPUT 8-ohm	Both ch, -20 dBm	+6.0 dB	+11.5 dBm	+11.5 dBm	+11.5 dBm	-3.5 dBm

LIM/PLDET/THM

LIM: Setting value of LIM (Limiter control)
* As this is a development menu, do not change the setting value.

PLDET: Power limiter detection
The A/D conversion value during operation is displayed.

THM: Thermo protection detection
The A/D conversion value during operation is displayed.
(Reference voltage: 3.3 V=255)

LIM/PLDET/THM

LIM: LIM(リミッター制御)の設定値
※ 開発用メニューのため、設定値の変更は行わないでください。

PLDET: パワーリミッターの検出
動作時のA/D変換値が表示されます。

THM: 温度プロテクションの検出
動作時のA/D変換値が表示されます。
(基準電圧: 3.3 V=255)

4.255:255: 68

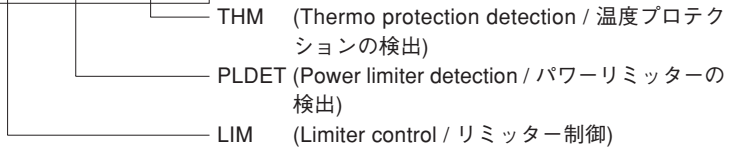

5. MIC CHECK

The signals input through the microphone are output of FRONT L/R via A/D and D/A.

5.MIC CHECK

5. MIC CHECK

マイク入力された信号をA/D-D/A経由でFRONT L/Rに出力します。

6. FL CHECK

Use this program to check the FL display section.
For audio signal processing, use STRAIGHT.

6. FL CHECK

FL表示部のチェックプログラムです。
オーディオ信号処理はSTRAIGHTです。

Checking FL display section / FL表示部のチェック

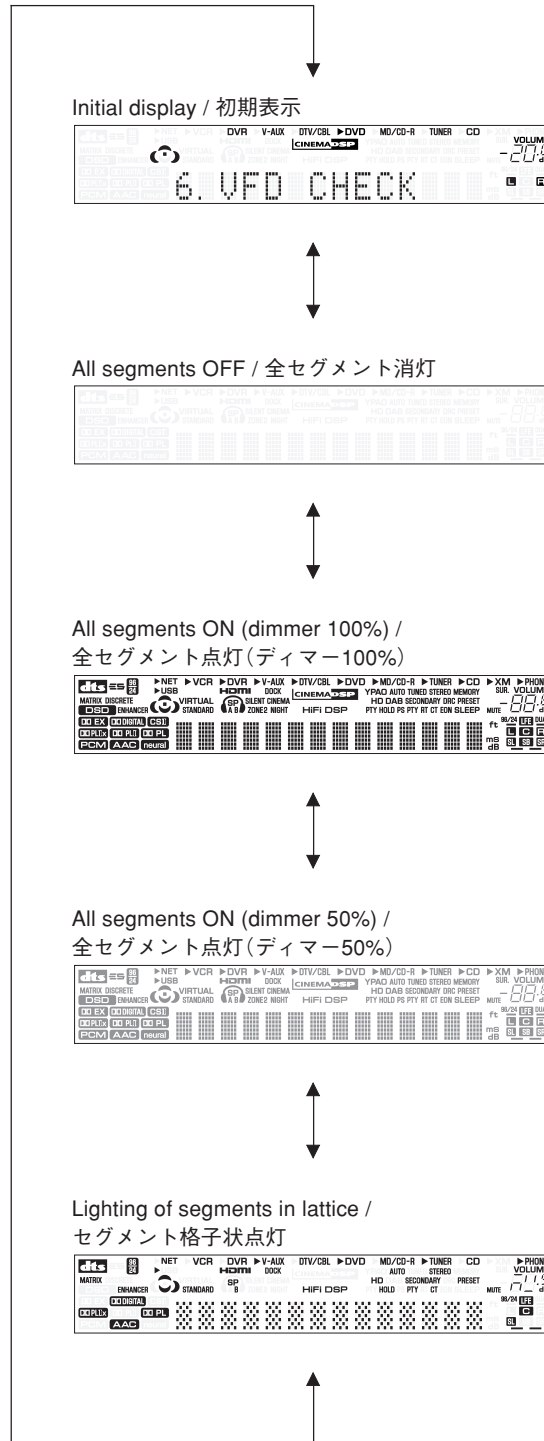

7. TEST TONE

The noise generator with a built-in microprocessor outputs the noise through the channels specified by the submenu.

The noise frequency for LFE (SUBWOOFER) is 35 to 80 Hz.

Other than that, the noise frequency is 500 to 2 kHz.

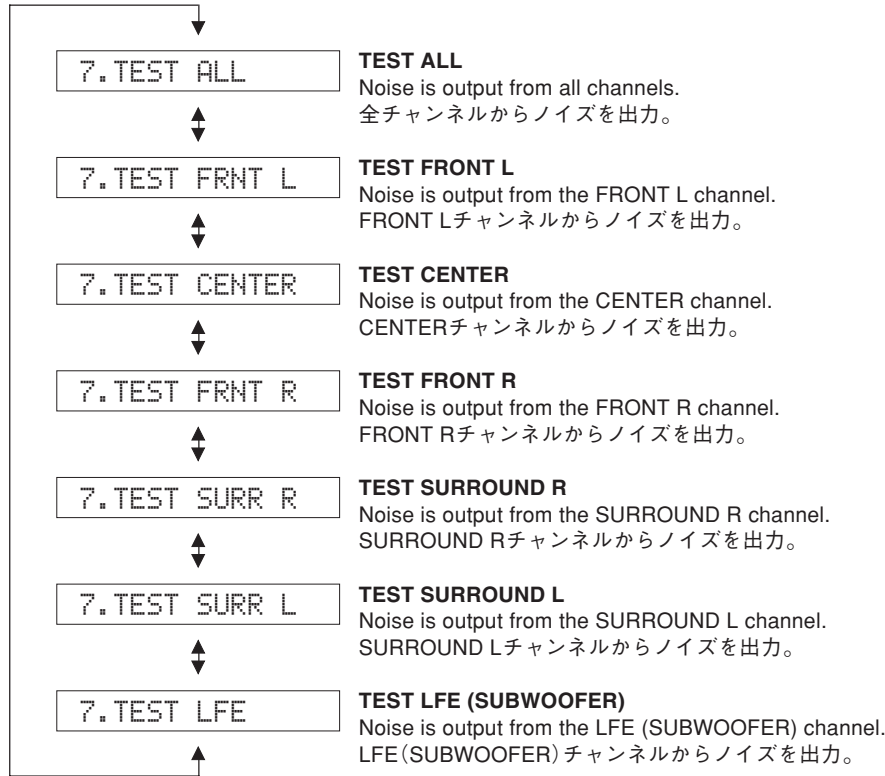

7. TEST TONE

マイコンに内蔵されているノイズ発生回路によって、サブメニューで指定したチャンネルへノイズを出力します。

LFE (SUBWOOFER)用のノイズ周波数は35~80 Hz、それ以外はノイズ周波数500~2 kHzとなります。

8. FACTORY PRESET

This menu is used to reserve and inhibit initialization of the back-up RAM.

The signals are processed using EFFECT OFF (The L/R signal is output using ANALOG BYPASS).

8. FACTORY PRESET

バックアップ用RAM(音場プログラムのパラメーターやセットメニュー内容等)の初期化を予約/禁止します。

信号処理はEFFECT OFF (ANALOG BYPASSでL/Rを出力)です。



CAUTION: Before setting to the PRESET RESERVED, write down the existing preset memory content of the tuner in a table as shown below. (This is because setting to the PRESET RESERVED will cause the user memory content of the tuner to be erased.)

Preset Group	P1	P2	P3	P4	P5	P6	P7	P8
A								
B								
C								
D								
E								

注意： PRESET RESERVEDを選んで初期化をする前に、チューナーのユーザーメモリー内容を下表に書き写してください。(初期化をすると、チューナーのユーザーメモリーの内容は消えてしまいます。)

9. A/D DATA CHECK

This menu is used to display the A/D conversion value of the microprocessor which detects panel keys of the main unit and protection functions in using the sub-menu.

When K0/K1 menu is selected, keys become non-operable due to detection of the values of all keys. However, it is possible to advance to the next sub-menu by turning the VOLUME of the main unit. When using this function, note that turning the VOLUME more than 1 click would cause the volume value to change.

During signal processing, the condition before execution is maintained.

* The figures in the diagram are given as reference only.

PD/PV

PD: PRD (Power amplifier DC protection detection)
The output of power amplifier DC (DC voltage) is detected.

Normal value: 35 to 81 (Reference voltage: 3.3 V=255)

PV: PRV (Voltage protection detection)
Voltage detects: ACL, AC2, 10V, S9, +12, -12, +5V and VP

Normal value: 84 to 153 (Reference voltage: 3.3 V=255)

* If PRD and PRV are out of the normal value range, the protection function works to turn off the power.

PD: 57 PV:116

TH/PL

TH: THM (Thermo protection detection)
The temperature of the heat sink is detected.

Normal value: 0 to 124 (Reference voltage: 3.3 V=255)

* If THM is out of the normal value range, the protection function works to turn off the power.

PL: PLDET (Power limiter detection)
The output voltage of power amplifier is detected.

TH: 83 PL:255

9. A/D DATA CHECK

本機パネルキー、プロテクションなどを検出しているマイコンのA/D変換値を、サブメニューで表示します。

K0/K1のメニューにすると、全キーの値を検出するためキー操作はできなくなりますが、本機のVOLUMEを回すことにより、次のサブメニューに進めることができます。このとき1クリック以上回すと、ボリューム値が変化するので注意してください。

信号処理は実行前の状態を維持します。

※ 図中の数値は参考例です。

PD/PV

PD: PRD(パワーアンプDCプロテクションの検出)
パワーアンプDC(直流電圧)出力の検出。

正常値: 35~81(基準電圧: 3.3 V=255)

PV: PRV(電圧プロテクションの検出)
検出電圧: ACL、AC2、10V、S9、+12、-12、+5V、VP

正常値: 84~153(基準電圧: 3.3 V=255)

※ PRDおよびPRVは正常値を外れるとプロテクションが働き、電源オフされます。

TH/PL

TH: THM(温度プロテクションの検出)
ヒートシンク温度の検出。

正常値: 0~124(基準電圧: 3.3 V=255)

※ THMは正常値を外れるとプロテクションが働き、電源オフされます。

PL: PLDET(パワーリミッターの検出)
パワーアンプ出力電圧の検出。

U, C models (Reference voltage: 3.3 V=255)

	During normal operation	Value for starting limiter operation	Value for canceling limiter operation
PLDET	255	77	100
LIM H: 255 / L: 102	H	L	H

(LIM: Limiter control)

R, T, K, A, B, G, E, L models (Reference voltage: 3.3 V=255)

	During normal operation	Value for starting limiter operation	Value for canceling limiter operation
PLDET	255	100	131
LIM H: 255 / L: 90	H	L	H

(LIM: Limiter control)

J model (基準電圧：3.3 V=255)

	通常値	リミッター動作開始値	リミッター動作解除値
PLDET	255	100	131
LIM H: 255 / L: 90	H	L	H

(LIM：リミッター制御)

PI/DE

PI: PRI (Current protection detection)
The current of the power amplifier is detected.
Normal value: 0 to 100 (Reference voltage: 3.3 V=255)

DE: PDET (Sub-trans power detection)
Normal value: 209 to 255 (Reference voltage: 3.3 V=255)

* If PRI and PDET are out of the normal value range, the protection function works to turn off the power.

PI/DE

PI: PRI (電流プロテクションの検出)
パワーアンプ電流の検出。
正常値： 0~100(基準電圧：3.3 V=255)

DE: PDET(サブトランス電源電圧の検出)
正常値： 209~255(基準電圧：3.3 V=255)

※ PRIおよびPDETは正常値を外れるとプロテクションが働き、電源オフされます。

PI: 33 DE:255

K0/K1

K0/K1: KEY0/KEY1 (Panel key of main unit)
A/D value of the key fails to function properly when the standard value is deviated by ± 4 .
In this case, check the constant of partial pressure resistor, solder condition, etc.
Refer to table.
(Reference voltage: 3.3 V=255)

K0/K1

K0/K1: KEY0/KEY1 (本機パネルキー)
キーのA/D値は基準値から ± 4 を外れると、正常な動きをしません。
下表をご覧になり、各キーの分圧抵抗の定数、ハンダ不良等の確認をしてください。
(基準電圧：3.3 V=255)

K0: 251 K1:252

Display / 表示	KEY0	KEY1
23 \pm 4	SCENE 1	SCENE 3
42 \pm 4	SCENE 2	SCENE 4
66 \pm 4	PROGRAM <	DIRECT
92 \pm 4	PROGRAM >	AUDIO SELECT
120 \pm 4	STRAIGHT	INPUT <
147 \pm 4	TONE CONTROL	INPUT >
165 \pm 4	SEARCH MODE	PRESET/TUNING <
182 \pm 4	FM/AM	PRESET/TUNING >
198 \pm 4	A/B/C/D/E	MEMORY
217 \pm 4	SPEAKERS	TUNING
255	(KEY OFF)	(KEY OFF)

10. XM STATUS (U, C models)

The output check of XM radio antenna module is executed.

10. XM STATUS (U、C models)

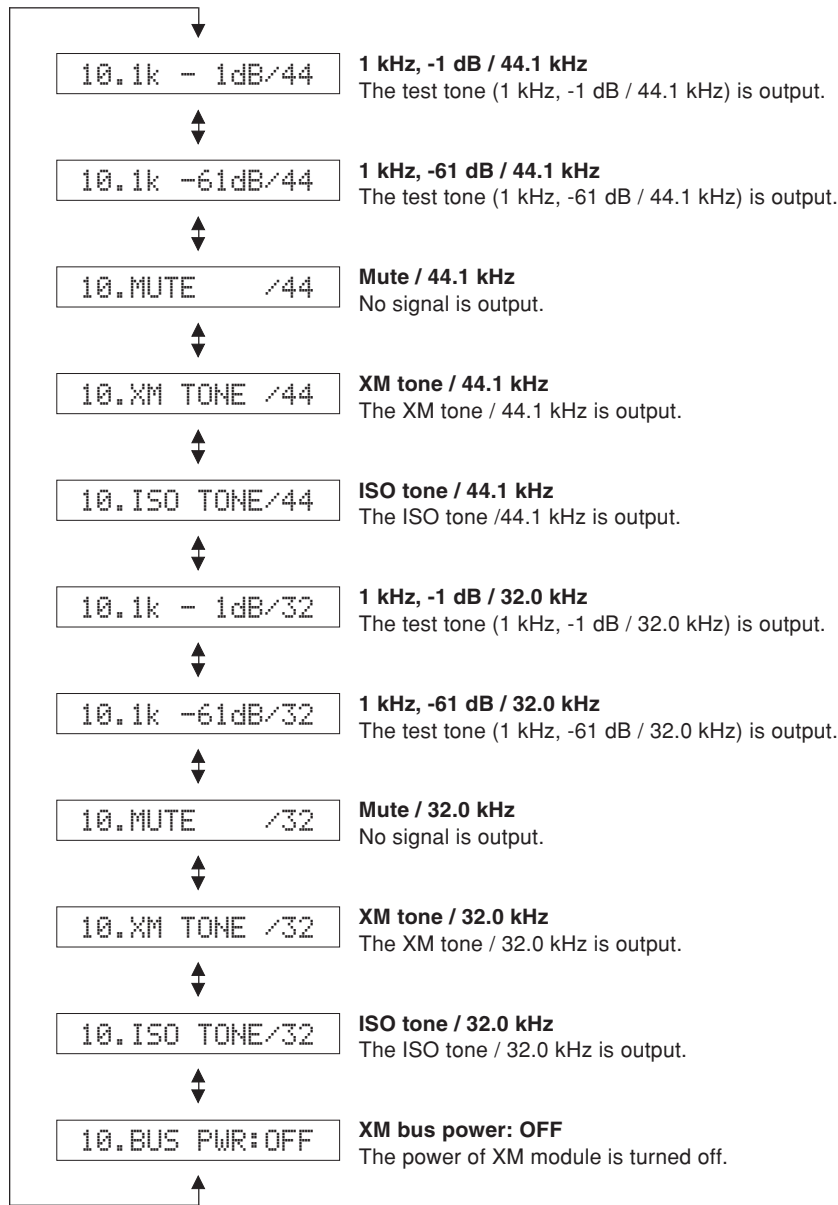

11. DOCK

Not applied to these models.

11. DOCK

このモデルには適用されません。



12. USB CHECK

Not applied to these models.

12. USB CHECK

このモデルには適用されません。



13. DAB CHECK

Not applied to these models.



13. DAB CHECK

このモデルには適用されません。

14. IF STATUS (Input function status)

Not applied to these models.



14. IF STATUS

このモデルには適用されません。

15. PROTECTION SETTING

The A/D setting value of each protection is displayed.
(Reference voltage: 3.3 V=255)

15. PROTECTION SETTING

各プロテクションのA/D設定値が表示されます。(基準電圧：3.3 V=255)

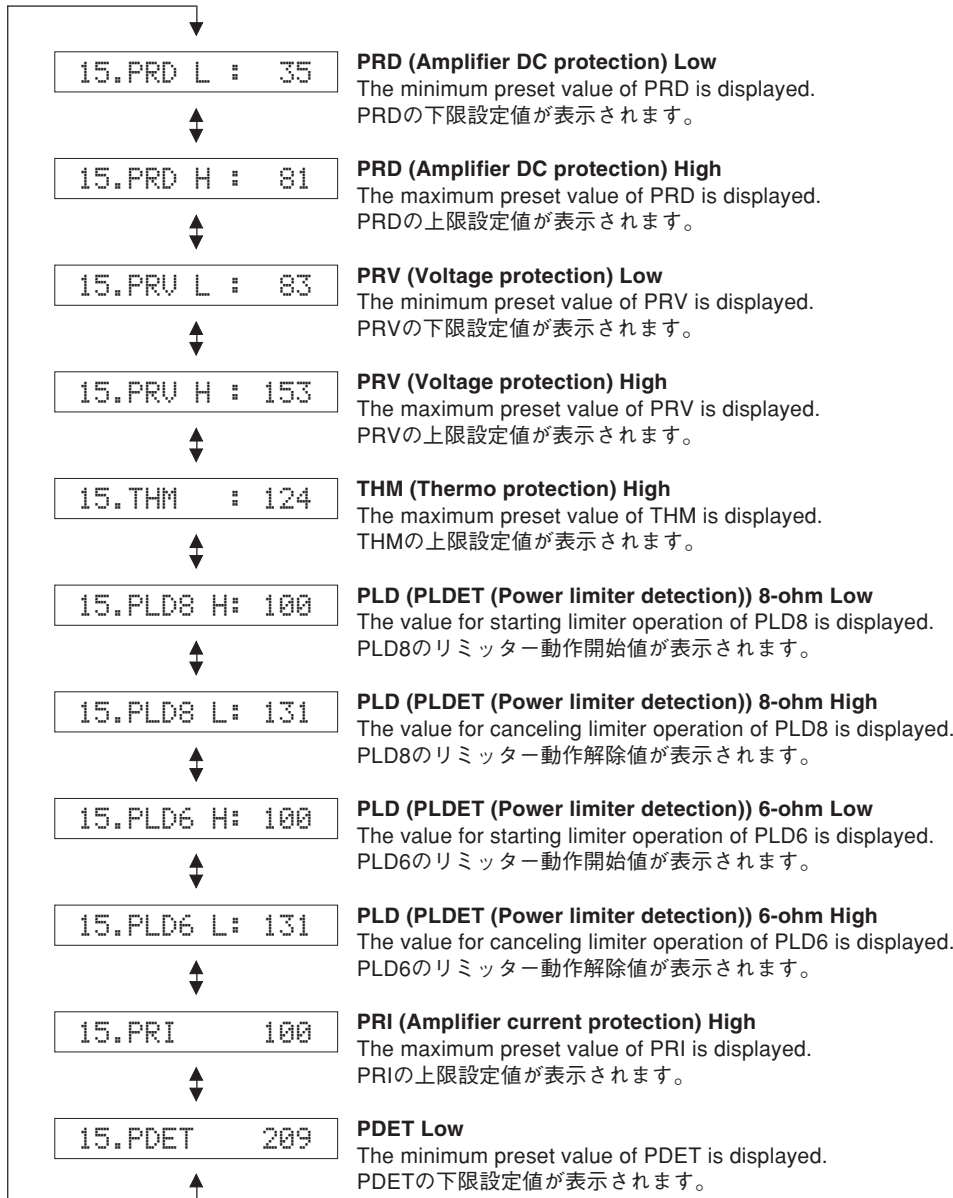

16. PROTECTION HISTORY

Four protection histories are displayed.

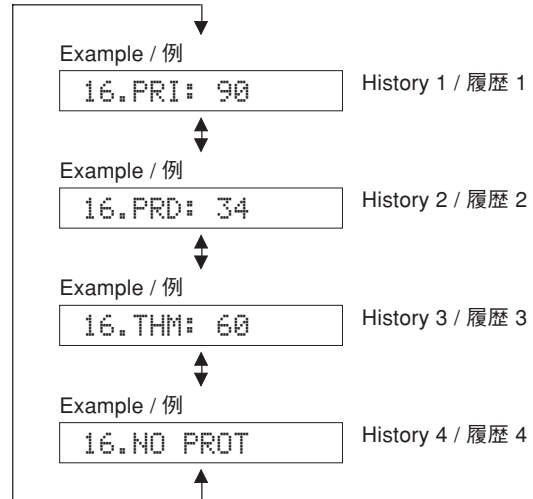

16. PROTECTION HISTORY

過去のプロテクション履歴が4つまで表示されます。

17. SOFT SWITCH

Note) As this is a development menu, do not change the function setting.
Changing the function setting may hinder the proper operation.

This menu is used to switch the function settings on P.C.B. through the software to activate the main unit. The protection function follows the P.C.B. settings.

* As this is a development menu, it is not possible to describe the details.

17. SOFT SWITCH

注) 開発用メニューのため、機能設定の変更は行わないでください。
機能設定を変更した場合、正常に動作しないことがあります。

P.C.B.上の機能設定をソフト的に切り替えて、本機を動作させる機能です。
プロテクション機能は、P.C.B.の設定に従います。

※ 開発用メニューのため、詳細に関しては記載できません。

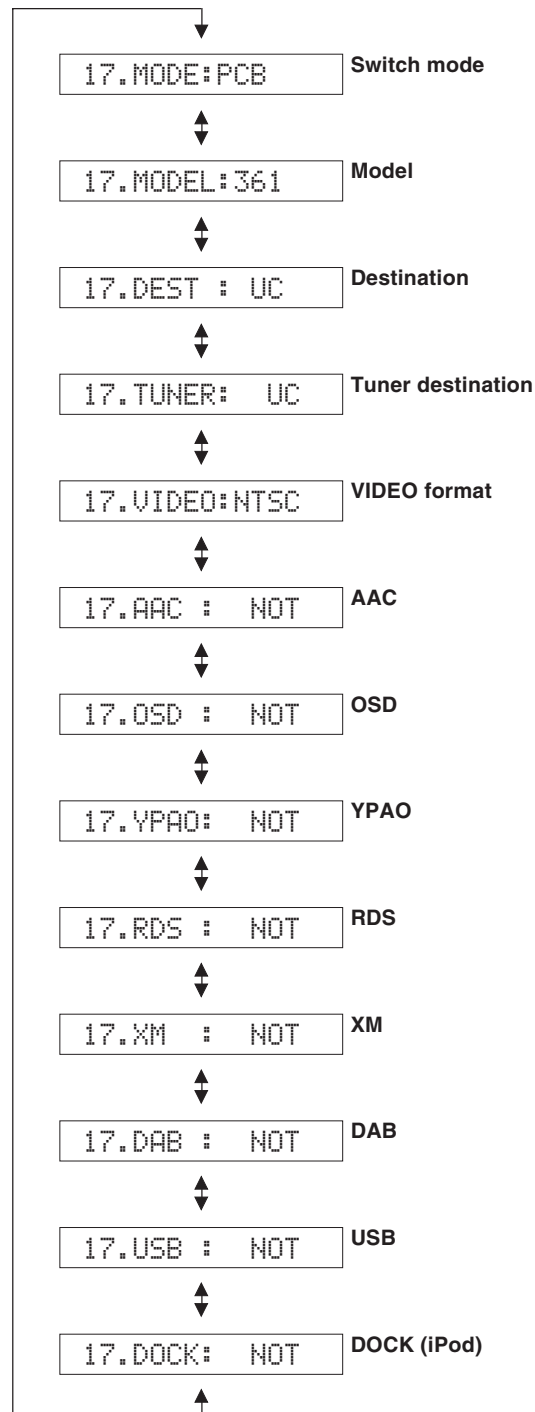

18. ROM VER/SUM

The version and checksum are displayed. The signal is processed using EFFECT OFF.

The checksum is obtained by adding the data at every 8 bits for each program area and expressing the result as a 4-figure hexadecimal data.

18. ROM VER/SUM

プログラムのバージョン、チェックサムを表示します。信号はエフェクトオフです。

チェックサムは、プログラムエリア別にデータを8ビットごとに加算していき、4桁の16進データで現したものです。

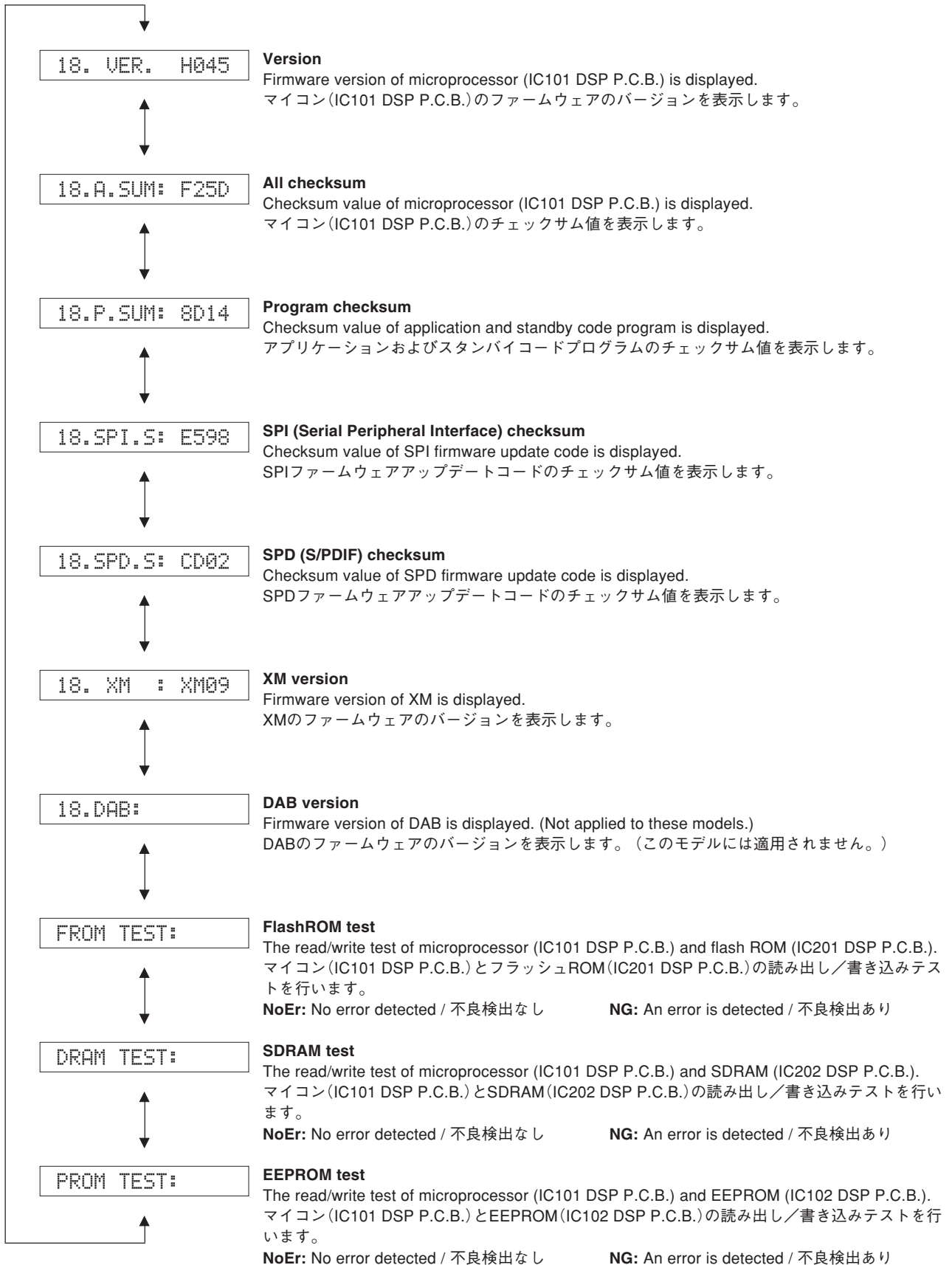

MEMO



■ DISPLAY DATA

● V2001 : 17-BT-29GNK (OPERATION P.C.B.)

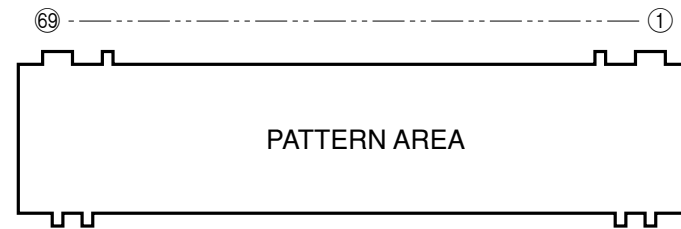

● PIN CONNECTION

Pin No.	69	68	67	66	65	64	63	62	61	60	59	58	57	56	55	54	53	52	51	50	49	48	47	46	45	44	43	42	41	40	39	38	37	36	35
Connection	F2	NX	NP	NP	P1	P2	P3	P4	P5	P6	P7	P8	P9	P10	P11	P12	P13	P14	P15	P16	P17	P18	P19	P20	P21	P22	P23	P24	P25	P26	P27	P28	P29	P30	P31

Pin No.	34	33	32	31	30	29	28	27	26	25	24	23	22	21	20	19	18	17	16	15	14	13	12	11	10	9	8	7	6	5	4	3	2	1
Connection	P32	P33	P34	P35	P36	P37	NX	NX	NX	NX	NX	NX	NX	17G	16G	15G	14G	13G	12G	11G	10G	9G	8G	7G	6G	5G	4G	3G	2G	1G	NP	NP	NX	F1

Note : 1) F1, F2 Filament pin 2) NP No pin 3) NX No extend pin 4) 1G-17G Grid pin

● GRID ASSIGNMENT

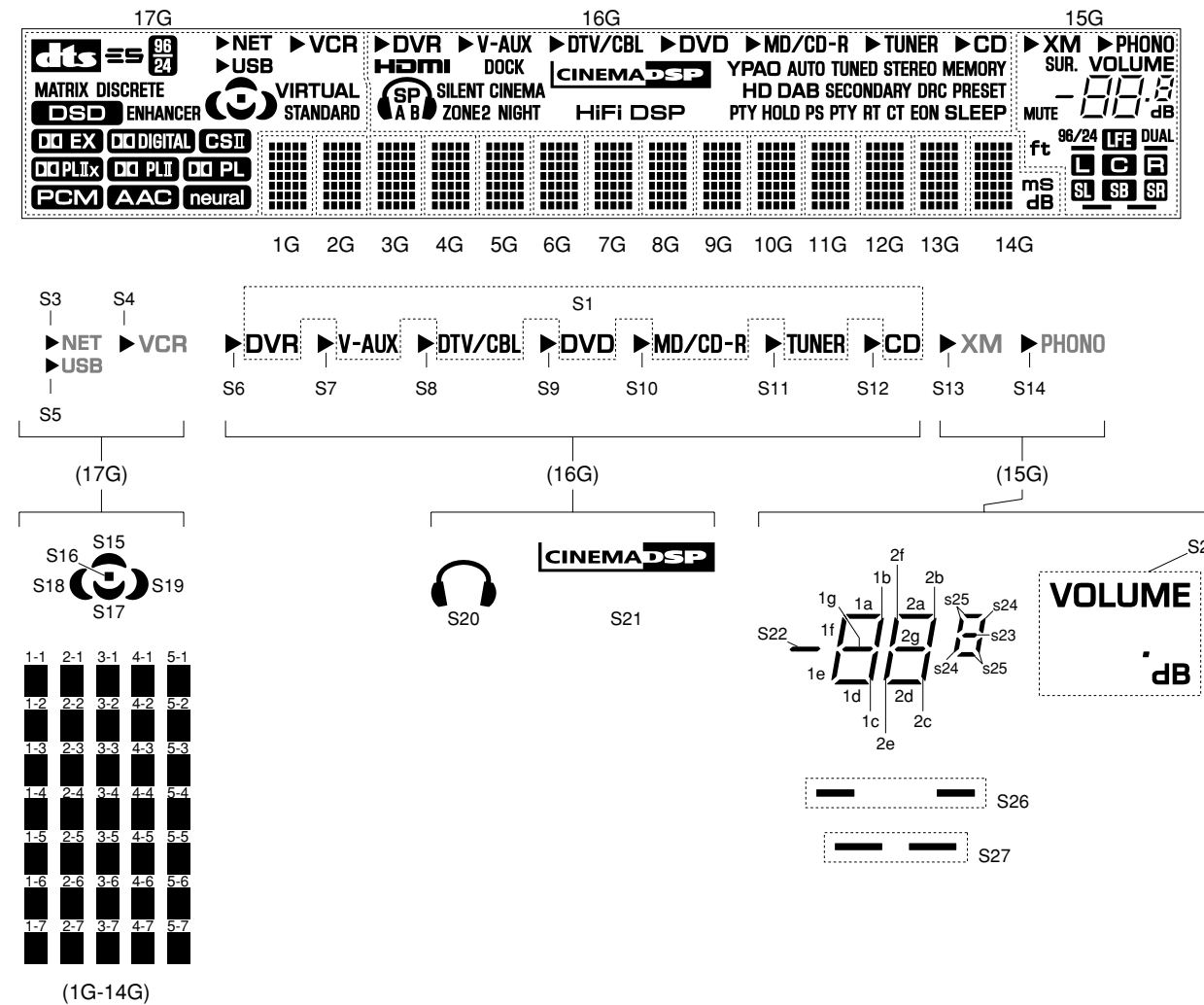

● ANODE CONNECTION

	17G	16G	15G	14G	13G-1G
1P	dtc	S1	S2	1-1	1-1
2P	ES	S6	S26	2-1	2-1
3P	MATRIX	S7	S27	3-1	3-1
4P	DISCRETE	S8	S22	4-1	4-1
5P	96/24	S9	1a	5-1	5-1
6P	DSD	S10	1b	1-2	1-2
7P	ENHANCER	S11	1c	2-2	2-2
8P	EX	S12	1d	3-2	3-2
9P	DIGITAL	HDMI	1e	4-2	4-2
10P	CSI	S20	1f	5-2	5-2
11P	PLIX	SP	1g	1-3	1-3
12P	PLI	A	2a	2-3	2-3
13P	PL	B	2b	3-3	3-3
14P	PCM	SILENT CINEMA	2c	4-3	4-3
15P	AAC	ZONE2	2d	5-3	5-3
16P	neural	NIGHT	2e	1-4	1-4
17P	NET	DOCK	2f	2-4	2-4
18P	USB	S21	2g	3-4	3-4
19P	VCR	HiFi DSP	S23	4-4	4-4
20P	S3	YPAO	S24	5-4	5-4
21P	S5	AUTO	S25	1-5	1-5
22P	S4	TUNED	XM	2-5	2-5
23P	S15	STEREO	PHONO	3-5	3-5
24P	S16	MEMORY	S13	4-5	4-5
25P	S17	HD	S14	5-5	5-5
26P	S18	DAB	SUR.	1-6	1-6
27P	S19	SECONDARY	MUTE	2-6	2-6
28P	VIRTUAL	DRC	DUAL	3-6	3-6
29P	STANDARD	PRESET	96/24	4-6	4-6
30P	-	PTY (HOLD)	ft	5-6	5-6
31P	-	HOLD	LFE	1-7	1-7
32P	-	PS	L	2-7	2-7
33P	-	PTY	C	3-7	3-7
34P	-	RT	R	4-7	4-7
35P	-	CT	SL	5-7	5-7
36P	-	EON	SB	mS	-
37P	-	SLEEP	SR	dB	-

IC DATA

IC101: ADSP-BF531 CPU (DSP P.C.B.) Microprocessor

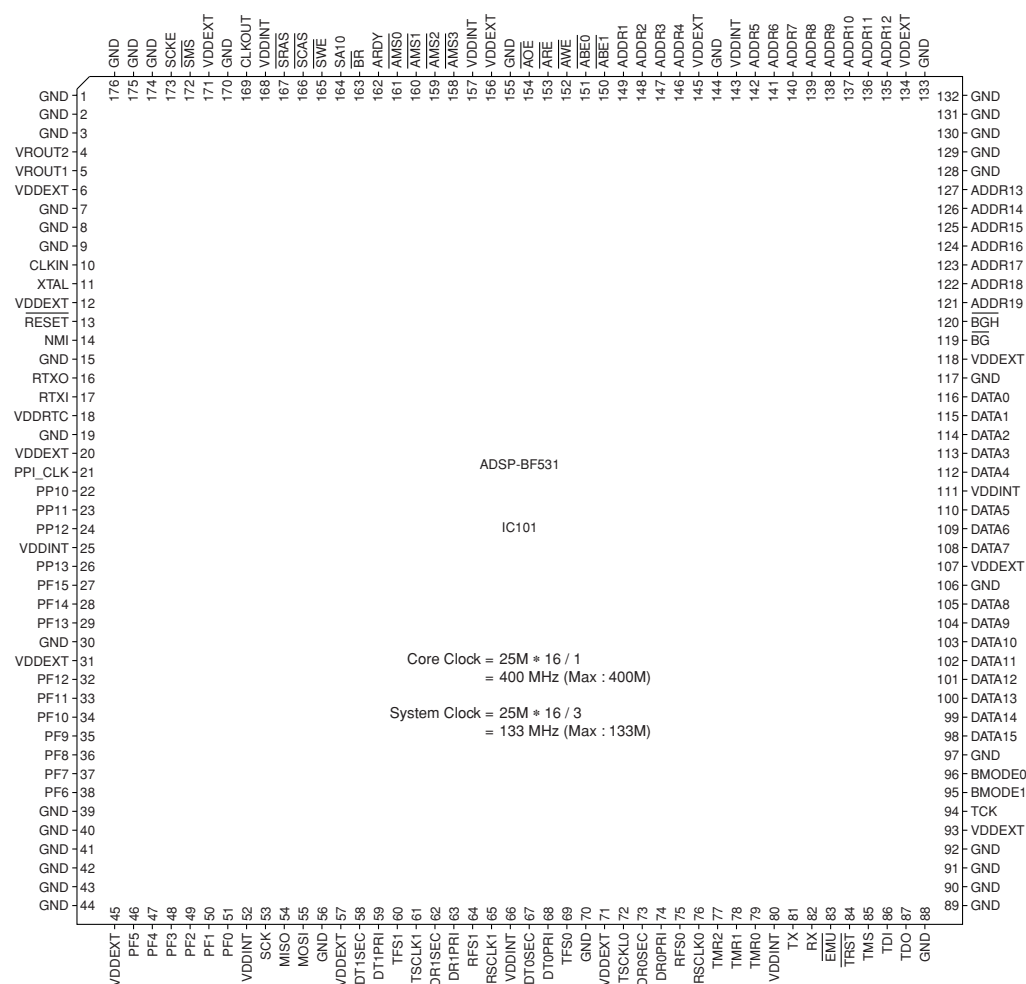
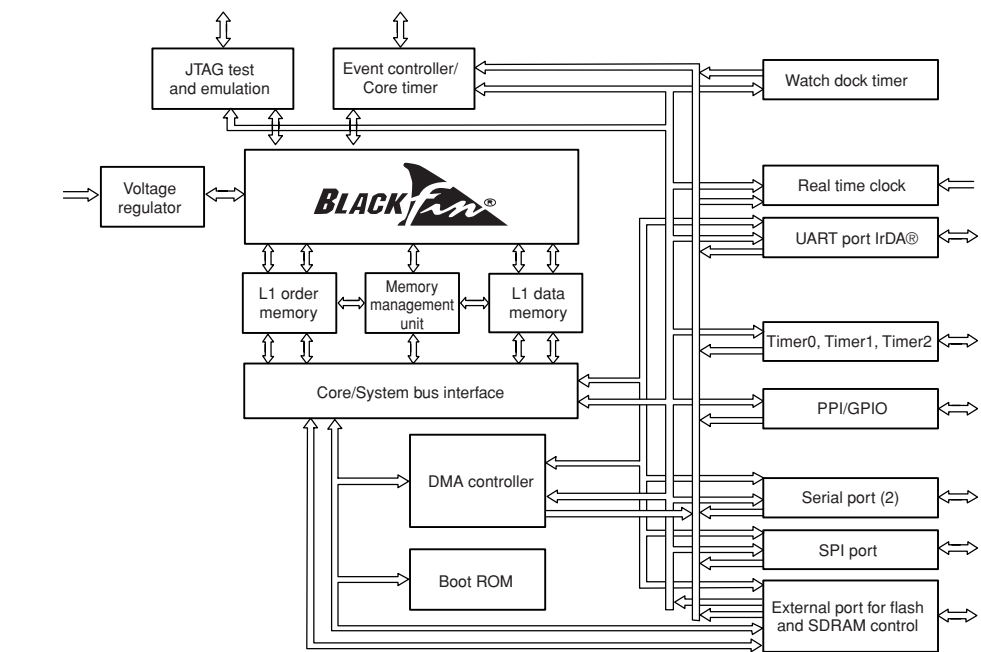

Pin No.	Port Name	Function Name	I/O	Detail of Function
1	DGND	GND	-	Ground of external
2	DGND	GND	-	Ground of external
3	DGND	GND	-	Ground of external
4	/VINTSW	VR0UT2	O	Voltage regulator drive for Q101
5	/VINTSW	VR0UT1	O	Voltage regulator drive for Q101
6	VDDEXT	VDDEXT	-	I/O power supply (EX3.3)
7	DGND	GND	-	Ground of external
8	DGND	GND	-	Ground of external
9	DGND	GND	-	Ground of external
10	CLKIN	CLKIN	I	Clock/oscillation input
11	XTAL	XTAL	O	Oscillation output
12	VDDEXT	VDDEXT	-	I/O power supply (EX3.3)
13	/DRESET	/RESET	I	Delayed reset
14	NMI/DGND	NMI	I	(Pull-down)
15	DGND	GND	-	Ground of external
16	-	RTXO	O	
17	RTXI/DGND	RTXI	I	(Pull-down)
18	-	VDDRTC	-	
19	DGND	GND	-	Ground of external
20	VDDEXT	VDDEXT	-	I/O power supply (EX3.3)
21	-	PPI_CLK	I	
22	-	PP10	I/O	
23	-	PP11	I/O	
24	-	PP12	I/O	
25	VDDINT	VDDINT	-	Power supply of microprocessor (BF1.2)
26	-	PP13	I/O	
27	VIB	PF15	O	Video select B
28	VIA	PF14	O	Video select A
29	-	PF13	I	
30	DGND	GND	-	Ground of external
31	VDDEXT	VDDEXT	-	I/O power supply (EX3.3)
32	/ICXM	PF12	O	Reset for XM (U, C models)
33	/XMPWR	PF11	O	XM power switch (U, C models)
34	INTAK	PF10	I	CODEC IC (IC301) interrupt
35	FSYNC/TFS0	PF9	I	Frame sync detect
36	R2A_DATA	PF8	O	DATA for R2A volume/select IC (IC162)
37	R2A_CLK	PF7	O	CLK for R2A volume/select IC (IC161)
38	VRB	PF6	I	Volume rotary B
39	DGND	GND	-	Ground of external
40	DGND	GND	-	Ground of external
41	DGND	GND	-	Ground of external
42	DGND	GND	-	Ground of external
43	DGND	GND	-	Ground of external
44	DGND	GND	-	Ground of external
45	VDDEXT	VDDEXT	-	I/O power supply (EX3.3)
46	VRA	PF5	I	Volume rotary A
47	REM	PF4	I	IR remote control pulse input
48	PSW	PF3	I	Power switch (STANDBY/ON)
49	/SPISEL2	PF2	O	CS for EEPROM (IC102)
50	/SPISEL1	PF1	O	CS for 4ch ADC (IC401)
51	/EXPE	PF0	O	Extended port enable
52	VDDINT	VDDINT	-	Power supply of microprocessor (BF1.2)
53	SPISCK	SCK	I/O	SPI clock
54	SPIMI	MISO	I/O	Master input/slave output
55	SPIMO	MOSI	I/O	Master output/slave input
56	DGND	GND	-	Ground of external
57	VDDEXT	VDDEXT	-	I/O power supply (EX3.3)
58	DT1SEC	DT1SEC	O	Serial port 1, secondary transmission data
59	DT1PRI	DT1PRI	O	Serial port 1, primary transmission data
60	TFS1	TFS1	I/O	Serial port 1, frame asynchronous transmission

Pin No.	Port Name	Function Name	I/O	Detail of Function
61	TSCLK1	TSCLK1	I/O	Serial port 1, serial transmission clock
62	DR1SEC	DR1SEC	I	Serial port 1, secondary reception data
63	DR1PRI	DR1PRI	I	Serial port 1, primary reception data
64	RFS1	RFS1	I/O	Serial port 1, frame synchronization reception
65	RSCLK1	RSCLK1	I/O	Serial port 1, serial reception clock
66	VDDINT	VDDINT	–	Power supply of microprocessor (BF1.2)
67	DT0SEC	DT0SEC	O	Serial port 0, secondary transmission data
68	DT0PRI	DT0PRI	O	Serial port 0, primary transmission data
69	TFS0	TFS0	I/O	Serial port 0, frame asynchronous transmission
70	DGND	GND	–	Ground of external
71	VDDEXT	VDDEXT	–	I/O power supply (EX3.3)
72	TSCLK0	TSCLK0	I/O	Serial port 0, serial transmission clock
73	DR0SEC	DR0SEC	I	Serial port 0, secondary reception data
74	DR0PRI	DR0PRI	I	Serial port 0, primary reception data
75	RFS0	RFS0	I/O	Serial port 0, frame synchronization reception
76	RSCLK0	RSCLK0	I/O	Serial port 0, serial reception clock
77	–	TMR2	I/O	
78	–	TMR1	I/O	
79	LIMITER	TMR0	O	Limiter control output
80	VDDINT	VDDINT	–	Power supply of microprocessor (BF1.2)
81	DTXM	TX	O	UART transmission for XM (U, C models)
82	DRXM	RX	I	UART reception for XM (U, C models)
83	–	/EMU	O	
84	–	/TRST	I	
85	–	TMS	I	
86	–	TDI	I	
87	–	TDO	O	
88	DGND	GND	–	Ground of external
89	DGND	GND	–	Ground of external
90	DGND	GND	–	Ground of external
91	DGND	GND	–	Ground of external
92	DGND	GND	–	Ground of external
93	VDDEXT	VDDEXT	–	I/O power supply (EX3.3)
94	–	TCK	I	
95	BMODE1	BMODE1	I	(Pull-down)
96	BMODE0	BMODE0	I	(Pull-up)
97	DGND	GND	–	Ground of external
98	D16	DATA15	I/O	SDRAM data bus 16
99	D15	DATA14	I/O	SDRAM data bus 15
100	D14	DATA13	I/O	SDRAM data bus 14
101	D13	DATA12	I/O	SDRAM data bus 13
102	D12	DATA11	I/O	SDRAM data bus 12
103	D11	DATA10	I/O	SDRAM data bus 11
104	D09	DATA9	I/O	SDRAM data bus 09
105	D08	DATA8	I/O	SDRAM data bus 08
106	DGND	GND	–	Ground of external
107	VDDEXT	VDDEXT	–	I/O power supply (EX3.3)
108	D07	DATA7	I/O	SDRAM data bus 07
109	D06	DATA6	I/O	SDRAM data bus 06
110	D05	DATA5	I/O	SDRAM data bus 05
111	VDDINT	VDDINT	–	Power supply of microprocessor (BF1.2)
112	D04	DATA4	I/O	SDRAM data bus 04
113	D03	DATA3	I/O	SDRAM data bus 03
114	D02	DATA2	I/O	SDRAM data bus 02
115	D01	DATA1	I/O	SDRAM data bus 01
116	D00	DATA0	I/O	SDRAM data bus 00
117	DGND	GND	–	Ground of external
118	VDDEXT	VDDEXT	–	I/O power supply (EX3.3)
119	–	/BG	O	
120	–	/BGH	O	

Pin No.	Port Name	Function Name	I/O	Detail of Function
121	A19	ADDR19	O	SDRAM address bus 19
122	A18	ADDR18	O	SDRAM address bus 18
123	A17	ADDR17	O	SDRAM address bus 17
124	A16	ADDR16	O	SDRAM address bus 16
125	A15	ADDR15	O	SDRAM address bus 15
126	A14	ADDR14	O	SDRAM address bus 14
127	A13	ADDR13	O	SDRAM address bus 13
128	DGND	GND	-	Ground of external
129	DGND	GND	-	Ground of external
130	DGND	GND	-	Ground of external
131	DGND	GND	-	Ground of external
132	DGND	GND	-	Ground of external
133	DGND	GND	-	Ground of external
134	VDDEXT	VDDEXT	-	I/O power supply (EX3.3)
135	A12	ADDR12	O	SDRAM address bus 12
136	A11	ADDR11	O	SDRAM address bus 11
137	A10	ADDR10	O	SDRAM address bus 10
138	A09	ADDR9	O	SDRAM address bus 09
139	A08	ADDR8	O	SDRAM address bus 08
140	A07	ADDR7	O	SDRAM address bus 07
141	A06	ADDR6	O	SDRAM address bus 06
142	A05	ADDR5	O	SDRAM address bus 05
143	VDDINT	VDDINT	-	Power supply of microprocessor (BF1.2)
144	DGND	GND	-	Ground of external
145	VDDEXT	VDDEXT	-	I/O power supply (EX3.3)
146	A04	ADDR4	O	SDRAM address bus 04
147	A03	ADDR3	O	SDRAM address bus 03
148	A02	ADDR2	O	SDRAM address bus 02
149	A01	ADDR1	O	SDRAM address bus 01
150	SDQM1	/ABE1	O	SDRAM byte enable/data mask 1
151	SDQM0	/ABE0	O	SDRAM byte enable/data mask 0
152	/AWE	/AWE	O	Write enable (Asynchronous)
153	/ARE	/ARE	O	Read enable
154	/AOE	/AOE	O	Output enable
155	DGND	GND	-	Ground of external
156	VDDEXT	VDDEXT	-	I/O power supply (EX3.3)
157	VDDINT	VDDINT	-	Power supply of microprocessor (BF1.2)
158	/AMS3	/AMS3	O	Bank select 3
159	/AMS2	/AMS2	O	Bank select 2
160	/AMS1	/AMS1	O	Bank select 1
161	/AMS0	/AMS0	O	Bank select 0
162	ARDY	ARDY	I	Hardware ready control
163	/BR	/BR	I	(Pull-up)
164	SA10	SA10	O	A10 pin
165	/SWE	/SWE	O	Write enable (Synchronization)
166	/SCAS	/SCAS	O	Sequence address strobe
167	/SRAS	/SRAS	O	Line address strobe
168	VDDINT	VDDINT	-	Power supply of microprocessor (BF1.2)
169	CLKOUT	CLKOUT	O	Clock output
170	DGND	GND	-	Ground of external
171	VDDEXT	VDDEXT	-	I/O power supply (EX3.3)
172	/SMS	/SMS	O	Bank select
173	SCKE	SCKE	O	Clock enable
174	DGND	GND	-	Ground of external
175	DGND	GND	-	Ground of external
176	DGND	GND	-	Ground of external

• **Microprocessor extended port**

IC204-IC206: SN74LV573APWR (DSP P.C.B.)

Octal 3-state D-latches with 3-state outputs

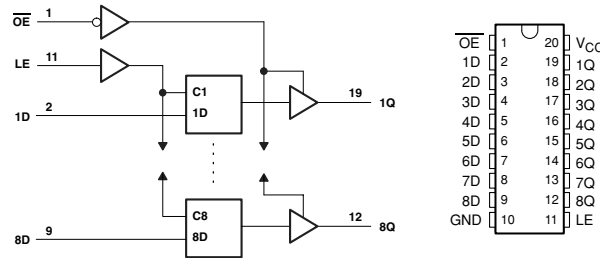

IC204

Pin No.	Port Name	Function Name	Detail of Function
1	/OE	/EXPE	Extended port enable
2	1D	D00	Data bus 00
3	2D	D01	Data bus 01
4	3D	D02	Data bus 02
5	4D	D03	Data bus 03
6	5D	D04	Data bus 04
7	6D	D05	Data bus 05
8	7D	D06	Data bus 06
9	8D	D07	Data bus 07
10	GND	DGND	Ground of external
11	LE	LEEX1	Bank select 1
12	8Q	/SPISEL3	CS for CODEC IC (IC301, DSP P.C.B.)
13	7Q	ADSEL2	4ch ADC input select 2
14	6Q	ADSEL1	4ch ADC input select 1
15	5Q	ADSEL0	4ch ADC input select 0
16	4Q	/CCBE	SPI bus switch
17	3Q	/CMT	Center mute
18	2Q	/SMT	Surround mute
19	1Q	/FMT	Front mute
20	VCC	EX3.3	Power supply

IC205

Pin No.	Port Name	Function Name	Detail of Function
1	/OE	/EXPE	Extended port enable
2	1D	D08	Data bus 08
3	2D	D09	Data bus 09
4	3D	D10	Data bus 10
5	4D	D11	Data bus 11
6	5D	D12	Data bus 12
7	6D	D13	Data bus 13
8	7D	D14	Data bus 14
9	8D	D15	Data bus 15
10	GND	DGND	Ground of external
11	LE	LEEX1	Bank select 1 (B, G, E models)
12	8Q	CLKSEL/RDS_RST	XM clock select (U, C models) / Reset for RDS (B, G, E models)
13	7Q	SSEL3	SCENE select LED switch 3
14	6Q	SSEL2	SCENE select LED switch 2
15	5Q	SSEL1	SCENE select LED switch 1
16	4Q	/IC_AK	IC for CODEC IC (IC301, DSP P.C.B.) and VFD (IC201, OPERATION P.C.B.)
17	3Q	/SPISEL4	CS for VFD (IC201, OPERATION P.C.B.)
18	2Q	/3.3SW	+3.3S switch
19	1Q	PRY	Power relay
20	VCC	EX3.3	Power supply

IC206

Pin No.	Port Name	Function Name	Detail of Function
1	/OE	/EXPE	Extended port enable
2	1D	D00	Data bus 00
3	2D	D01	Data bus 01
4	3D	D02	Data bus 02
5	4D	D03	Data bus 03
6	5D	D04	Data bus 04
7	6D	D05	Data bus 05
8	7D	D06	Data bus 06
9	8D	D07	Data bus 07
10	GND	DGND	Ground of external
11	LE	LEEX2	Bank select 2
12	8Q	/VR1	Video select R
13	7Q	SPISEL5	CE for tuner
14	6Q	/8ohmSW	AC H/L relay (RY106, MAIN P.C.B.)
15	5Q	HPRY	Headphone relay (RY102, MAIN P.C.B.)
16	4Q	MRYA	Main speakers A relay (RY101, MAIN P.C.B.)
17	3Q	MRYB	Main speakers B relay (RY102, MAIN P.C.B.)
18	2Q	CSRY	Center/surround speakers relay (RY103/R Y105, MAIN P.C.B.)
19	1Q	/SWMT	Subwoofer mute
20	VCC	EX3.3	Power supply

• **Microprocessor ADC select port**

IC401: ADC084S021CIMM (DSP P.C.B.)
4-channel, 200 kSPS, 8-bit A/D converter

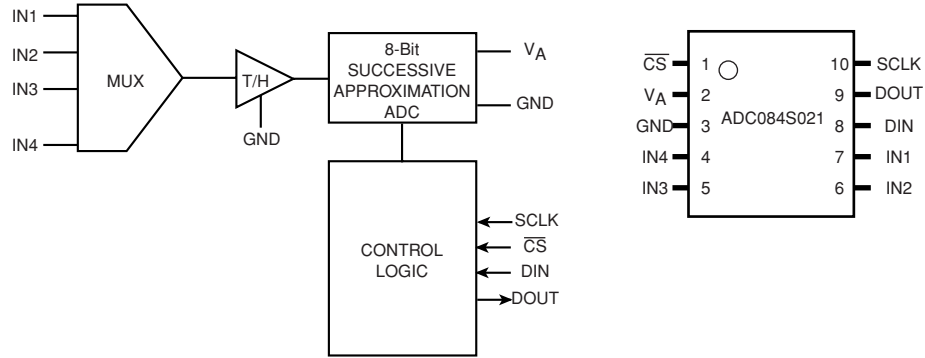

Pin No.	Port Name	Function Name	Detail of Function
1	/CS	/SPISEL1	CS for microprocessor
2	VA	VA	+3.3S
3	GND	DGND	Ground of external
4	IN4	IN4	SPI bus COM (IC402)
5	IN3	IN3	SPI bus COM (IC403)
6	IN2	KEY1	Key input 1
7	IN1	KEY0	Key input 0
8	DIN	SPIMO	Master output/slave input
9	DOUT	SPIMI	Master input/slave output
10	SCLK	SPISCK	SPI clock

Key input (A/D), pull-up resistance 10 k-ohms

Ohm [ohm]	+1.0 k	+1.0 k	+1.5 k	+2.2 k	+3.3 k	+4.7 k	+4.7 k	+6.8 k	+10.0 k	+22.0 k
V [V]	0.3	0.55	0.86	1.2	1.56	1.91	2.14	2.36	2.57	2.81
KEY0 (7 pin)	SCENE 1	SCENE 2	PROGRAM <	PROGRAM >	STRAIGHT	tone CONTROL	SEARCH MODE	FM/AM	A/B/C/D/E	SPEAKERS
KEY1 (6 pin)	SCENE 3	SCENE 4	DIRECT	AUDIO SELECT	INPUT <	INPUT >	PRESET/TUNING <	PRESET/TUNING >	MEMORY	TUNING

IC402, IC403: SN74LV4051APWR (DSP P.C.B.)
8-channel analog multiplexers/demultiplexers

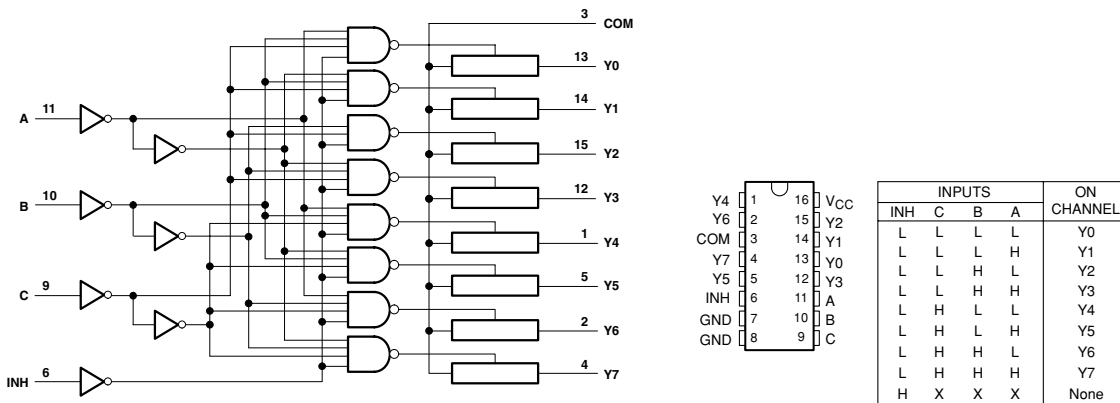

IC402

Pin No.	Port Name	Function Name	Detail of Function
1	Y4	–	
2	Y6	–	
3	COM	COM	SPI bus IN4 (IC401)
4	Y7	LINKACTIVE	Link detect (U, C models)
5	Y5	XM_MUTE	XM mute (U, C models)
6	INH	DGND	(Pull-down)
7	GND	DGND	Ground of external
8	GND	DGND	Ground of external
9	COM	ADSEL2	Input select 2
10	B	ADSEL1	Input select 1
11	A	ADSEL0	Input select 0
12	Y3	–	
13	Y0	–	
14	Y1	/ST	Stereo for tuner
15	Y2	/TUNED	Tuned for tuner
16	Vcc	+3.3S	Power supply

IC403

Pin No.	Port Name	Function Name	Detail of Function
1	Y4	DEST	Destination 1 *
2	Y6	/PDET	Sub-trans detect
3	COM	COM	SPI bus IN3 (IC401)
4	Y7	/HP	Headphone detect
5	Y5	PRIIN	Current protection
6	INH	DGND	(Pull-down)
7	GND	DGND	Ground of external
8	GND	DGND	Ground of external
9	COM	ADSEL2	Input select 2
10	B	ADSEL1	Input select 1
11	A	ADSEL0	Input select 0
12	Y3	PLDET	Limiter detect
13	Y0	PRDIN	Amplifier DC detect
14	Y1	PRVIN	Voltage protection
15	Y2	THMIN	Thermo protection
16	Vcc	+3.3S	Power supply

* Destination for A/D port

R406 [ohm]	1.5 k	5.6 k	1 k	6.8 k	6.8 k	8.2 k	3.3 k
R407 [ohm]	3.3 k	22 k	8.2 k	5.6 k	3.3 k	2.2 k	4.7 k
DEST (1 pin) [V]	2.1-2.5	2.5-2.8	2.8-3.1	1.3-1.7	0.9-1.3	0.5-0.9	1.8-2.1
A/D value (3.3 V=255)	164-189	190-215	216-239	100-132	70-99	42-69	133-163
Destination	J	U, C	R	T	K, A	B, G, E	L

IC301: AK4588VQ (DSP P.C.B.)
2/8-channel audio CODEC with DIR

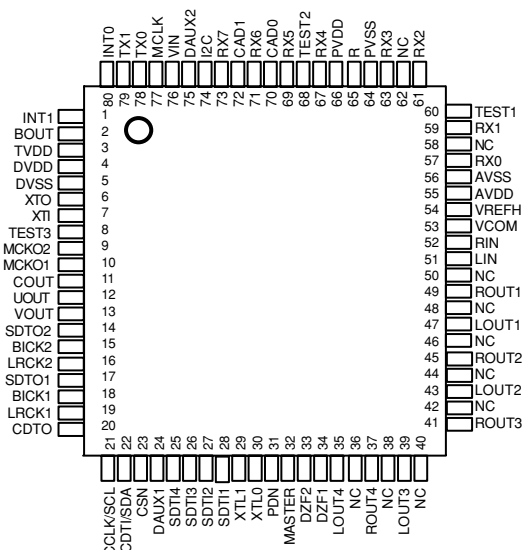
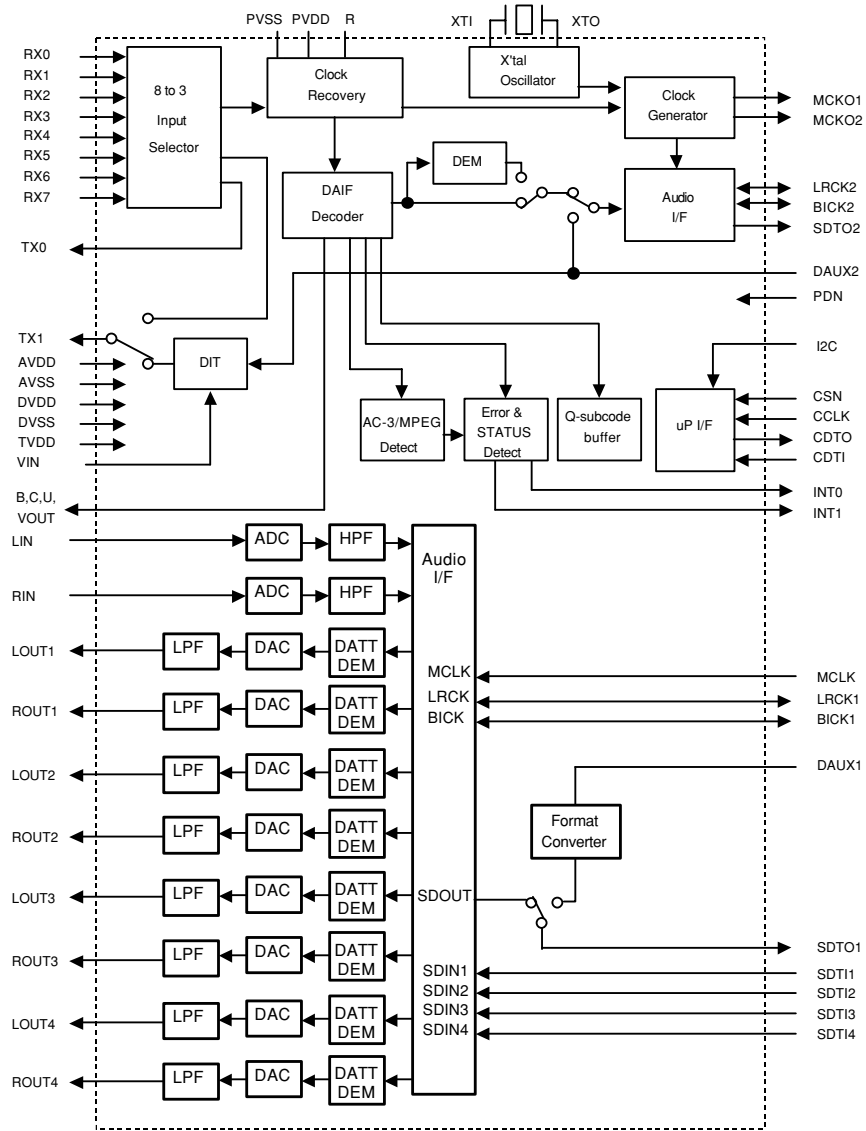

Pin No.	Function Name	I/O	Detail of Function
1	INT1	O	Interrupt 1 pin
2	BOUT	O	Block-start output pin for receiver input "H" during first 40 frames
3	TVDD	–	Output buffer power supply pin, 2.7 V to 5.5 V
4	DVDD	–	Digital power supply pin, 4.5 V to 5.5 V
5	DVSS	–	Digital ground pin
6	XTO	O	X'tal clock output pin
7	XTI	I	X'tal / External clock input pin
8	TEST3	I	Test 3 pin This pin should be connected to DVSS
9	MCKO2	O	Master clock output 2 pin
10	MCKO1	O	Master clock output 1 pin
11	COOUT	O	C-bit output pin for receiver input
12	UOUT	O	U-bit output pin for receiver input
13	VOOUT	O	V-bit output pin for receiver input
14	SDTO2	O	Audio serial data output pin (DIR/DIT part)
15	BICK2	I/O	Audio serial data clock pin (DIR/DIT part)
16	LRCK2	I/O	Channel clock pin (DIR/DIT part)
17	SDTO1	O	Audio serial data output pin (ADC/DAC part)
18	BICK1	I/O	Audio serial data clock pin (ADC/DAC part)
19	LRCK1	I/O	Input channel clock pin
20	CDTO	O	Control data output pin in serial mode, I2C pin= "L"
21	CCLK	I	Control data clock pin in serial mode, I2C pin= "L"
	SCL	I	Control data clock pin in serial mode, I2C pin= "H"
22	CDTI	I	Control data input pin in serial mode, I2C pin= "L"
	SDA	I/O	Control data pin in serial mode, I2C pin= "H"
23	CSN	I	Chip select pin in serial mode, I2C pin="L"
		I	This pin should be connected to DVSS, I2C pin="H"
24	DAUX1	I	AUX audio serial data input pin (ADC/DAC part)
25	SDTI4	I	DAC4 audio serial data input pin
26	SDTI3	I	DAC3 audio serial data input pin
27	SDTI2	I	DAC2 audio serial data input pin
28	SDTI1	I	DAC1 audio serial data input pin
29	XTL1	I	X'tal frequency select 0 pin
30	XTL0	I	X'tal frequency select 1 pin
31	PDN	I	Power-down mode pin When "L", the AK4588 is powered-down, all output pin goes "L", all registers are reset When CAD1-0 pins are changed, the AK4588 should be reset by PDN pin
32	MASTER	I	Master mode select pin "H": Master mode, "L": Slave mode
33	DZF2	O	Zero input detect 2 pin (table 13) When the input data of the group 1 follow total 8192 LRCK cycles with "0" input data, this pin goes to "H" / When RSTN1 bit is "0" or PWDAN bit is "0", this pin goes to "H"
	OVF	O	Analog input overflow detect pin This pin goes to "H" if the analog input of L ch or R ch overflows This pin becomes OVF pin if OVFE bit is set to 1
34	DZF1	O	Zero input detect 1 pin (table 13) When the input data of the group 1 follow total 8192 LRCK cycles with "0" input data, this pin goes to "H" / When RSTN1 bit is "0" or PWDAN bit is "0", this pin goes to "H"
35	LOUT4	O	DAC4 L ch analog output pin
36	NC	–	No connect pin No internal bonding / This pin should be opened
37	ROUT4	O	DAC4 R ch analog output pin
38	NC	–	No connect pin No internal bonding / This pin should be opened
39	LOUT3	O	DAC3 L ch analog output pin
40	NC	–	No connect pin No internal bonding / This pin should be opened

Pin No.	Function Name	I/O	Detail of Function
41	ROUT3	O	DAC3 R ch analog output pin
42	NC	–	No connect pin No internal bonding / This pin should be opened
43	LOUT2	O	DAC2 L ch analog output pin
44	NC	–	No connect pin No internal bonding / This pin should be opened
45	ROUT2	O	DAC2 R ch analog output pin
46	NC	–	No connect pin No internal bonding / This pin should be opened
47	LOUT1	O	DAC1 L ch analog output pin
48	NC	–	No connect pin No internal bonding / This pin should be opened
49	ROUT1	O	DAC1 R ch analog output pin
50	NC	–	No connect pin No internal bonding / This pin should be opened
51	LIN	I	L ch analog input pin
52	RIN	I	R ch analog input pin
53	VCOM	–	Common voltage output pin 2.2 F capacitor should be connected to AVSS externally
54	VREFH	–	Positive voltage reference input pin, AVDD
55	AVDD	–	Analog power supply pin, 4.5 V to 4.5 V
56	AVSS	–	Analog ground pin, 0 V
57	RX0	I	Receiver channel 0 pin (Internal biased pin / Internally biased at PVDD/2)
58	NC	–	No connect pin No internal bonding / This pin should be connected to PVSS
59	RX1	I	Receiver channel 1 pin (Internal biased pin / Internally biased at PVDD/2)
60	TEST1	I	Test 1 pin This pin should be connected to PVSS
61	RX2	I	Receiver channel 2 pin (Internal biased pin / Internally biased at PVDD/2)
62	NC	–	No connect pin No internal bonding / This pin should be connected to PVSS
63	RX3	I	Receiver channel 3 pin (Internal biased pin / Internally biased at PVDD/2)
64	PVSS	–	PLL ground pin
65	R	–	External resistor pin 12 k-ohms +/-1 % resistor should be connected to PVSS externally
66	PVDD	–	PLL power supply pin, 4.5 V to 4.5 V
67	RX4	I	Receiver channel 4 pin (Internal biased pin / Internally biased at PVDD/2)
68	TEST2	I	Test 2 pin This pin should be connected to PVSS
69	RX5	I	Receiver channel 5 pin (Internal biased pin / Internally biased at PVDD/2)
70	CAD0	I	Chip address 0 pin (ADC/DAC part)
71	RX6	I	Receiver channel 6 pin (Internal biased pin / Internally biased at PVDD/2)
72	CAD1	I	Chip address 1 pin (ADC/DAC part)
73	RX7	I	Receiver channel 7 pin (Internal biased pin / Internally biased at PVDD/2)
74	I2C	I	Control mode select pin “L”: 4-wire serial, “H”: I2C bus
75	DAUX2	I	Auxiliary audio data input pin (DIR/DIT part)
76	VIN	I	V-bit input pin for transmitter output
77	MCLK	I	Master clock input pin
78	TX0	O	Transmit channel (through data) output 0 pin
79	TX1	O	Transmit channel output 1 pin When TX bit = “0”, transmit channel (through data) output 1 pin. When TX bit = “1”, transmit channel (DAUX2 data) output pin (default)
80	INT0	O	Interrupt 0 pin

Note: All input pins except internal biased pins and internal pull-down pin should not be left floating.

IC161: R2A15215FP (MAIN P.C.B.)
 8-channel electronic volume with 11 input selector and tone control

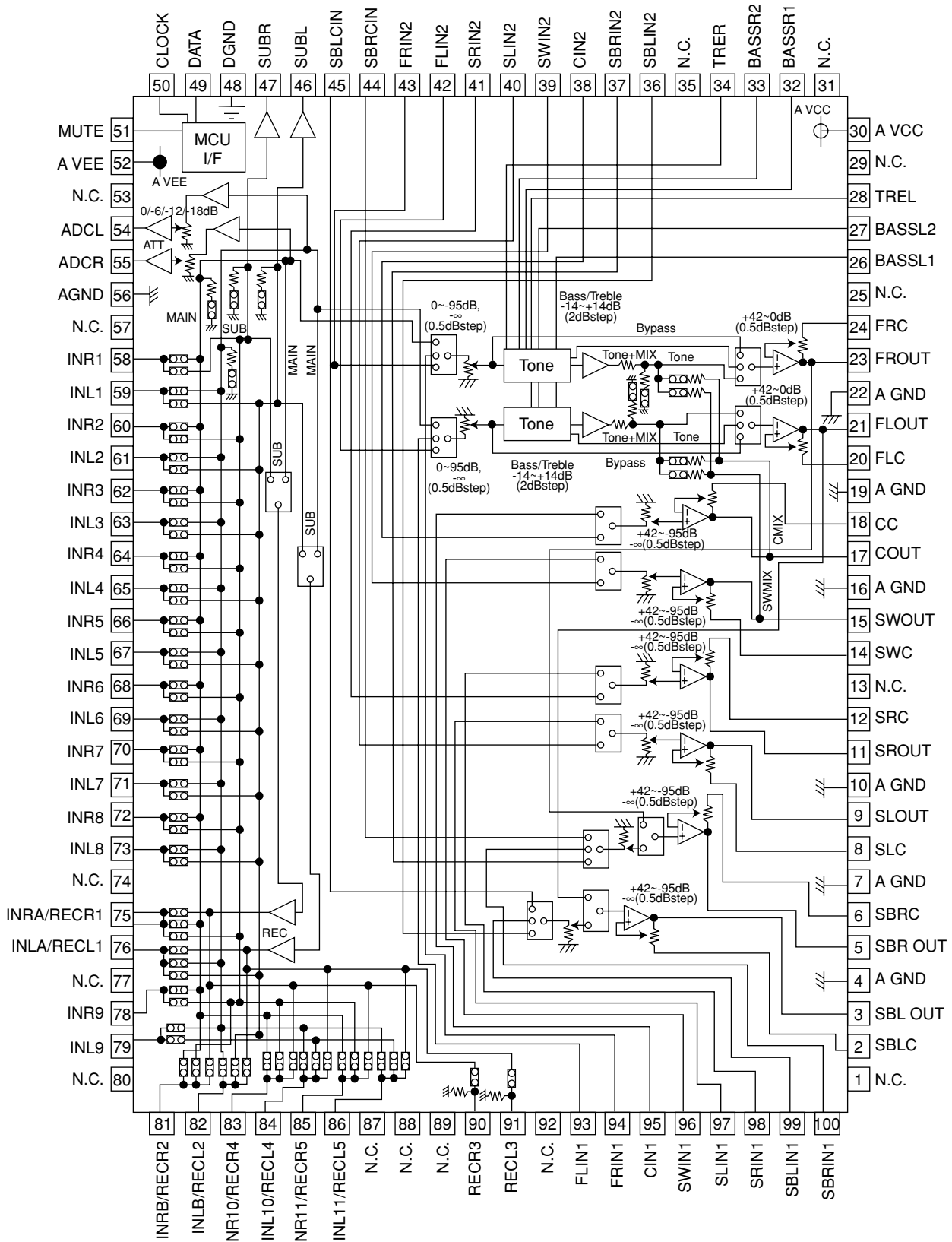

Pin No.	Function Name	Detail of Function
1	N.C.	No connected
2	SBLC	L/R/C/SW/SL/SR/SBL/SBR ch terminal to connect capacitor to reduce noise from changing the volume
3	SBLOUT	FL/FR/C/SW/SL/SR/SBL/SBR ch output terminal
4	AGND	Analog GND terminal
5	SBROUT	FL/FR/C/SW/SL/SR/SBL/SBR ch output terminal
6	SBRC	L/R/C/SW/SL/SR/SBL/SBR ch terminal to connect capacitor to reduce noise from changing the volume
7	AGND	Analog GND terminal
8	SLC	L/R/C/SW/SL/SR/SBL/SBR ch terminal to connect capacitor to reduce noise from changing the volume
9	SLOUT	FL/FR/C/SW/SL/SR/SBL/SBR ch output terminal
10	AGND	Analog GND terminal
11	SROUT	FL/FR/C/SW/SL/SR/SBL/SBR ch output terminal
12	SRC	L/R/C/SW/SL/SR/SBL/SBR ch terminal to connect capacitor to reduce noise from changing the volume
13	N.C.	No connected
14	SWC	L/R/C/SW/SL/SR/SBL/SBR ch terminal to connect capacitor to reduce noise from changing the volume
15	SWOUT	FL/FR/C/SW/SL/SR/SBL/SBR ch output terminal
16	AGND	Analog GND terminal
17	COUT	FL/FR/C/SW/SL/SR/SBL/SBR ch output terminal
18	CC	L/R/C/SW/SL/SR/SBL/SBR ch terminal to connect capacitor to reduce noise from changing the volume
19	AGND	Analog GND terminal
20	FLC	L/R/C/SW/SL/SR/SBL/SBR ch terminal to connect capacitor to reduce noise from changing the volume
21	FLOUT	FL/FR/C/SW/SL/SR/SBL/SBR ch output terminal
22	AGND	Analog GND terminal
23	FROUT	FL/FR/C/SW/SL/SR/SBL/SBR ch output terminal
24	FRC	L/R/C/SW/SL/SR/SBL/SBR ch terminal to connect capacitor to reduce noise from changing the volume
25	N.C.	No connected
26	BASSL1	L/R ch tone control (Bass) terminal for setting frequency characteristics
27	BASSL2	L/R ch tone control (Bass) terminal for setting frequency characteristics
28	TREL	L/R ch tone control (Treble) terminal for setting frequency characteristics
29	N.C.	No connected
30	AVCC	Positive side power terminal
31	N.C.	No connected
32	BASSR1	L/R ch tone control (Bass) terminal for setting frequency characteristics
33	BASSR2	L/R ch tone control (Bass) terminal for setting frequency characteristics
34	TRER	L/R ch tone control (Treble) terminal for setting frequency characteristics
35	N.C.	No connected
36	SBLIN2	L/R/C/SW/SL/SR/SBL/SBR ch input terminal (multi input 1/2)
37	SBRIN2	L/R/C/SW/SL/SR/SBL/SBR ch input terminal (multi input 1/2)
38	CIN2	L/R/C/SW/SL/SR/SBL/SBR ch input terminal (multi input 1/2)
39	SWIN2	L/R/C/SW/SL/SR/SBL/SBR ch input terminal (multi input 1/2)
40	SLIN2	L/R/C/SW/SL/SR/SBL/SBR ch input terminal (multi input 1/2)
41	SRIN2	L/R/C/SW/SL/SR/SBL/SBR ch input terminal (multi input 1/2)
42	FLIN2	L/R/C/SW/SL/SR/SBL/SBR ch input terminal (multi input 1/2)
43	FRIN2	L/R/C/SW/SL/SR/SBL/SBR ch input terminal (multi input 1/2)
44	SBRCIN	SBL/SBR ch volume input terminal
45	SBLCIN	SBL/SBR ch volume input terminal
46	SUBL	L/R ch SUB output terminal
47	SUBR	L/R ch SUB output terminal
48	DGND	Digital GND terminal
49	DATA	Control data input terminal
50	CLOCK	Control data input terminal
51	MUTE	External Mute Control terminal
52	AVEE	Negative side power terminal
53	N.C.	No connected
54	ADCL	L/R ch ADC output terminal
55	ADCR	L/R ch ADC output terminal

Pin No.	Function Name	Detail of Function
56	AGND	Analog GND terminal
57	N.C.	No connected
58	INR1	L/R ch input terminal (input selector)
59	INL1	L/R ch input terminal (input selector)
60	INR2	L/R ch input terminal (input selector)
61	INL2	L/R ch input terminal (input selector)
62	INR3	L/R ch input terminal (input selector)
63	INL3	L/R ch input terminal (input selector)
64	INR4	L/R ch input terminal (input selector)
65	INL4	L/R ch input terminal (input selector)
66	INR5	L/R ch input terminal (input selector)
67	INL5	L/R ch input terminal (input selector)
68	INR6	L/R ch input terminal (input selector)
69	INL6	L/R ch input terminal (input selector)
70	INR7	L/R ch input terminal (input selector)
71	INL7	L/R ch input terminal (input selector)
72	INR8	L/R ch input terminal (input selector)
73	INL8	L/R ch input terminal (input selector)
74	N.C.	No connected
75	INRA/RECR1	L/R ch input terminal (input selector) / L/R ch REC output terminal
76	INLA/RECL1	L/R ch input terminal (input selector) / L/R ch REC output terminal
77	N.C.	No connected
78	INR9	L/R ch input terminal (input selector)
79	INL9	L/R ch input terminal (input selector)
80	N.C.	No connected
81	INRB/RECR2	L/R ch input terminal (input selector) / L/R ch REC output terminal
82	INLB/RECL2	L/R ch input terminal (input selector) / L/R ch REC output terminal
83	INR10/RECR4	L/R ch input terminal (input selector) / L/R ch REC output terminal
84	INL10/RECL4	L/R ch input terminal (input selector) / L/R ch REC output terminal
85	INR11/RECR5	L/R ch input terminal (input selector) / L/R ch REC output terminal
86	INL11/RECL5	L/R ch input terminal (input selector) / L/R ch REC output terminal
87	N.C.	No connected
88	N.C.	No connected
89	N.C.	No connected
90	RECR3	L/R ch REC output terminal
91	RECL3	L/R ch REC output terminal
92	N.C.	No connected
93	FLIN1	L/R/C/SW/SL/SR/SBL/SBR ch input terminal (multi input 1/2)
94	FRIN1	L/R/C/SW/SL/SR/SBL/SBR ch input terminal (multi input 1/2)
95	CIN1	L/R/C/SW/SL/SR/SBL/SBR ch input terminal (multi input 1/2)
96	SWIN1	L/R/C/SW/SL/SR/SBL/SBR ch input terminal (multi input 1/2)
97	SLIN1	L/R/C/SW/SL/SR/SBL/SBR ch input terminal (multi input 1/2)
98	SRIN1	L/R/C/SW/SL/SR/SBL/SBR ch input terminal (multi input 1/2)
99	SBLIN1	L/R/C/SW/SL/SR/SBL/SBR ch input terminal (multi input 1/2)
100	SBRIN1	L/R/C/SW/SL/SR/SBL/SBR ch input terminal (multi input 1/2)

IC201: M66003-0131FP-R (OPERATION P.C.B.)
 18 digit 5x7 segment VFD controller/driver

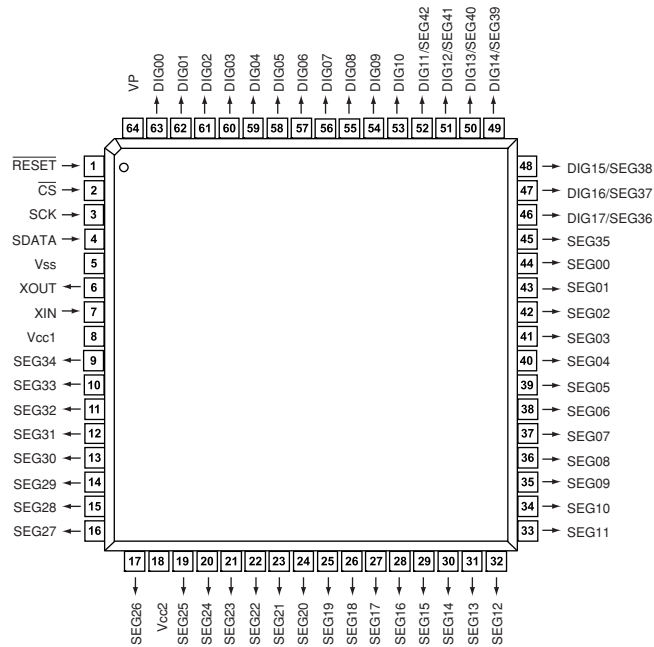
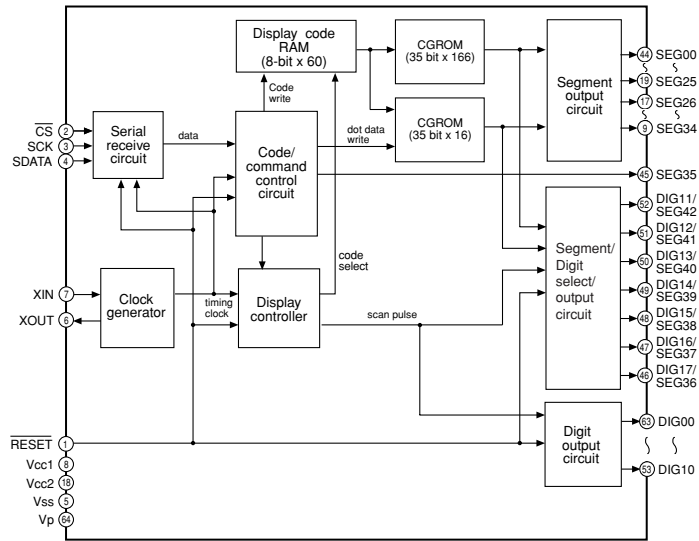

Pin No.	Port Name	Function Name	I/O	Detail of Function
1	Reset	/RESET	Reset input	When "L", M66003 is initialized
2	CS	/CEFL	Chip select input	When "L", communication with the MCU is possible When "H", any instruction from the MCU is neglected
3	SCK	CKFL	Shift clock input	Serial input data is taken and shifted by the positive edge of SCK
4	SDATA	DTFL	Serial data input	
5	Vss	VSS		GND (0V)
6	XOUT	XOUT	Clock output	When use as a CR oscillator, connect external resistor and capacitor / When use an external clock, input external clock to XIN, and XOUT must be opened
7	XIN	XIN	Clock input	
8	Vcc1	VDD		Positive power supply for internal logic
9	SEG34	P11	Segment output	Positive power supply for DIG and SEG outputs
10	SEG33	P2	Segment output	
11	SEG32	P3	Segment output	
12	SEG31	P4	Segment output	
13	SEG30	P5	Segment output	
14	SEG29	P6	Segment output	
15	SEG28	P7	Segment output	
16	SEG27	P8	Segment output	
17	SEG26	P9	Segment output	
18	Vcc2	VDD		
19	SEG25	P10	Segment output	Connect to segment (anode) pins of VFD
20	SEG24	P11	Segment output	
21	SEG23	P12	Segment output	
22	SEG22	P13	Segment output	
23	SEG21	P14	Segment output	
24	SEG20	P15	Segment output	
25	SEG19	P16	Segment output	
26	SEG18	P17	Segment output	
27	SEG17	P18l	Segment output	
28	SEG16	P19	Segment output	
29	SEG15	P20	Segment output	
30	SEG14	P21	Segment output	
31	SEG13	P22	Segment output	
32	SEG12	P23	Segment output	
33	SEG11	P24	Segment output	
34	SEG10	P25	Segment output	
35	SEG09	P26	Segment output	
36	SEG08	P27	Segment output	
37	SEG07	P28	Segment output	
38	SEG06	P29	Segment output	
39	SEG05	P30	Segment output	
40	SEG04	P31	Segment output	
41	SEG03	P32	Segment output	
42	SEG02	P33	Segment output	
43	SEG01	P34	Segment output	
44	SEG00	P35	Segment output	
45	SEG35	P36	Segment output	
46	DIG17/SEG36	P37	Segment output	Connect to digit (grid) pins of VFD
47	DIG16/SEG37	G17l	Digit output	
48	DIG15/SEG38	G16l	Digit output	
49	DIG14/SEG39	G15l	Digit output	
50	DIG13/SEG40	G14	Digit output	
51	DIG12/SEG41	G13	Digit output	
52	DIG11/SEG42	G12	Digit output	
53	DIG10	G11	Digit output	
54	DIG09	G10	Digit output	
55	DIG08	G9	Digit output	
56	DIG07	G8	Digit output	
57	DIG06	G7	Digit output	
58	DIG05	G6	Digit output	
59	DIG04	G5	Digit output	
60	DIG03	G4	Digit output	
61	DIG02	G3	Digit output	
62	DIG01	G2	Digit output	
63	DIG00	G1	Digit output	
64	Vp	VP		

BLOCK DIAGRAMS

Video, Audio and Power Supply Sections

MAIN U, C, R, T, K, A, B, G, E, L models
• See page 78, 79 → SCHEMATIC DIAGRAM

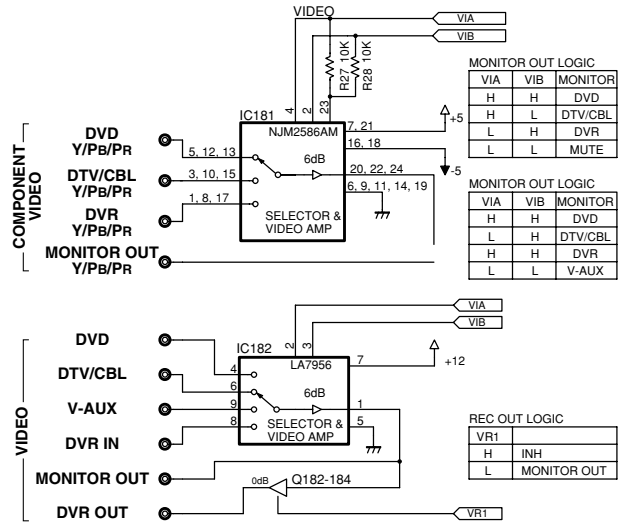

D-VIDEO J model
• See page 80 → SCHEMATIC DIAGRAM

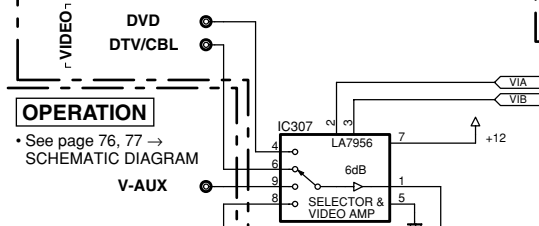

OPERATION
• See page 76, 77 → SCHEMATIC DIAGRAM

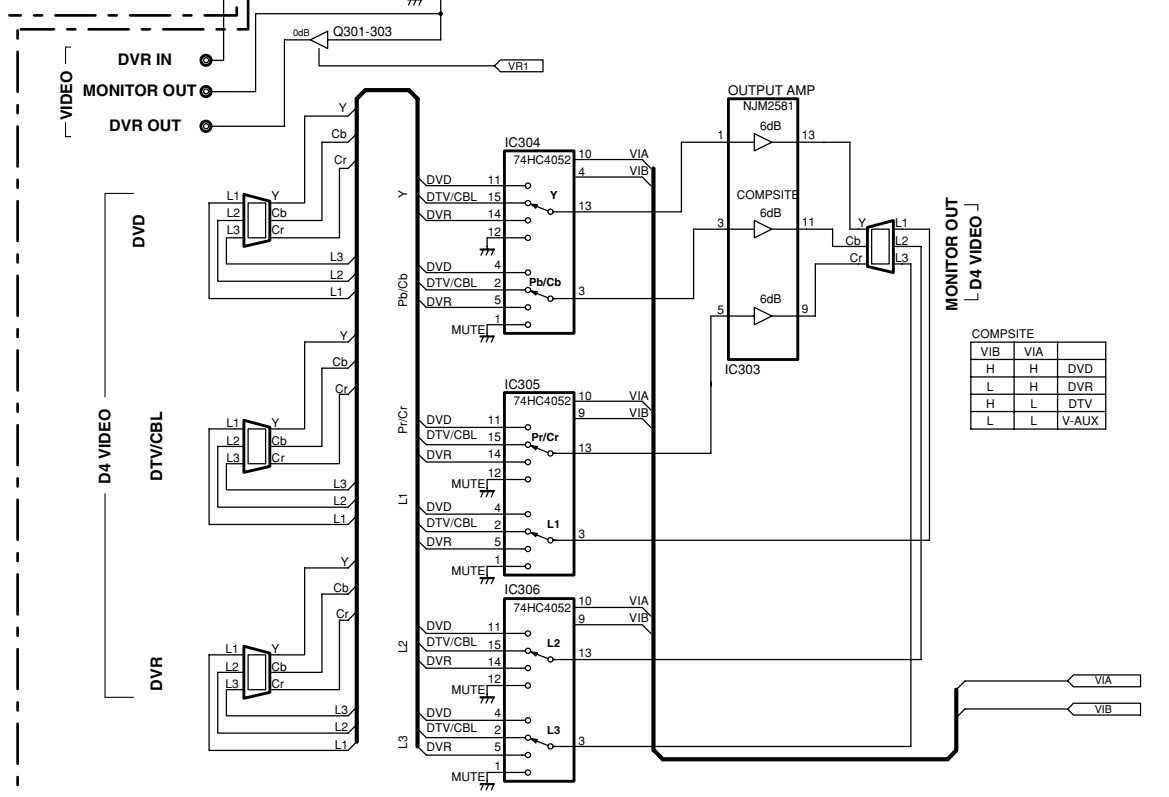

DSP • See page 71-75 → SCHEMATIC DIAGRAM

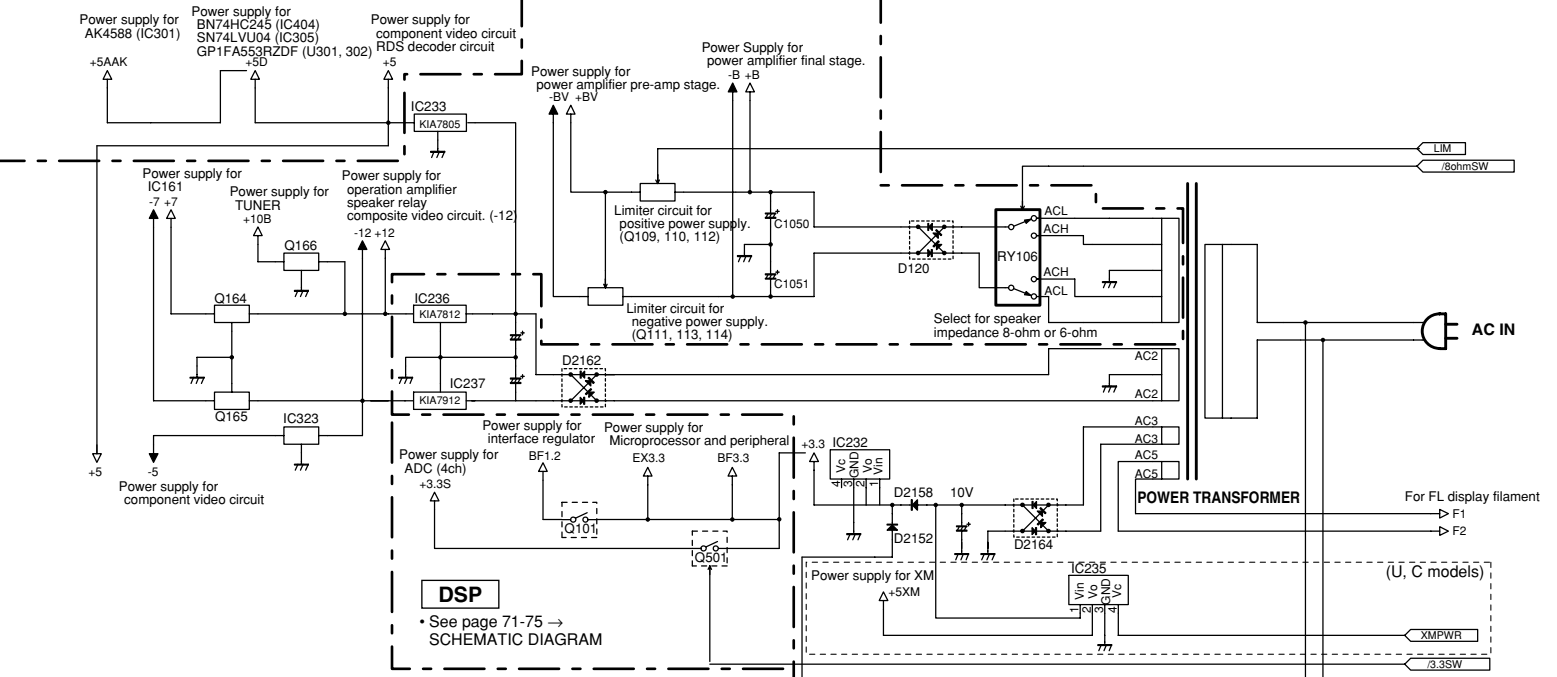

OPERATION
• See page 76, 77 → SCHEMATIC DIAGRAM

DSP
• See page 71-75 → SCHEMATIC DIAGRAM

MAIN • See page 78, 79 → SCHEMATIC DIAGRAM

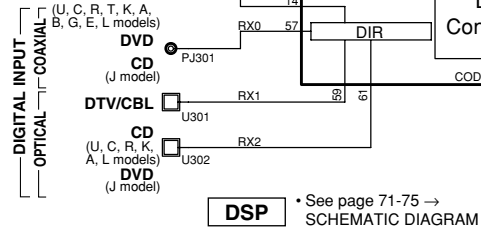
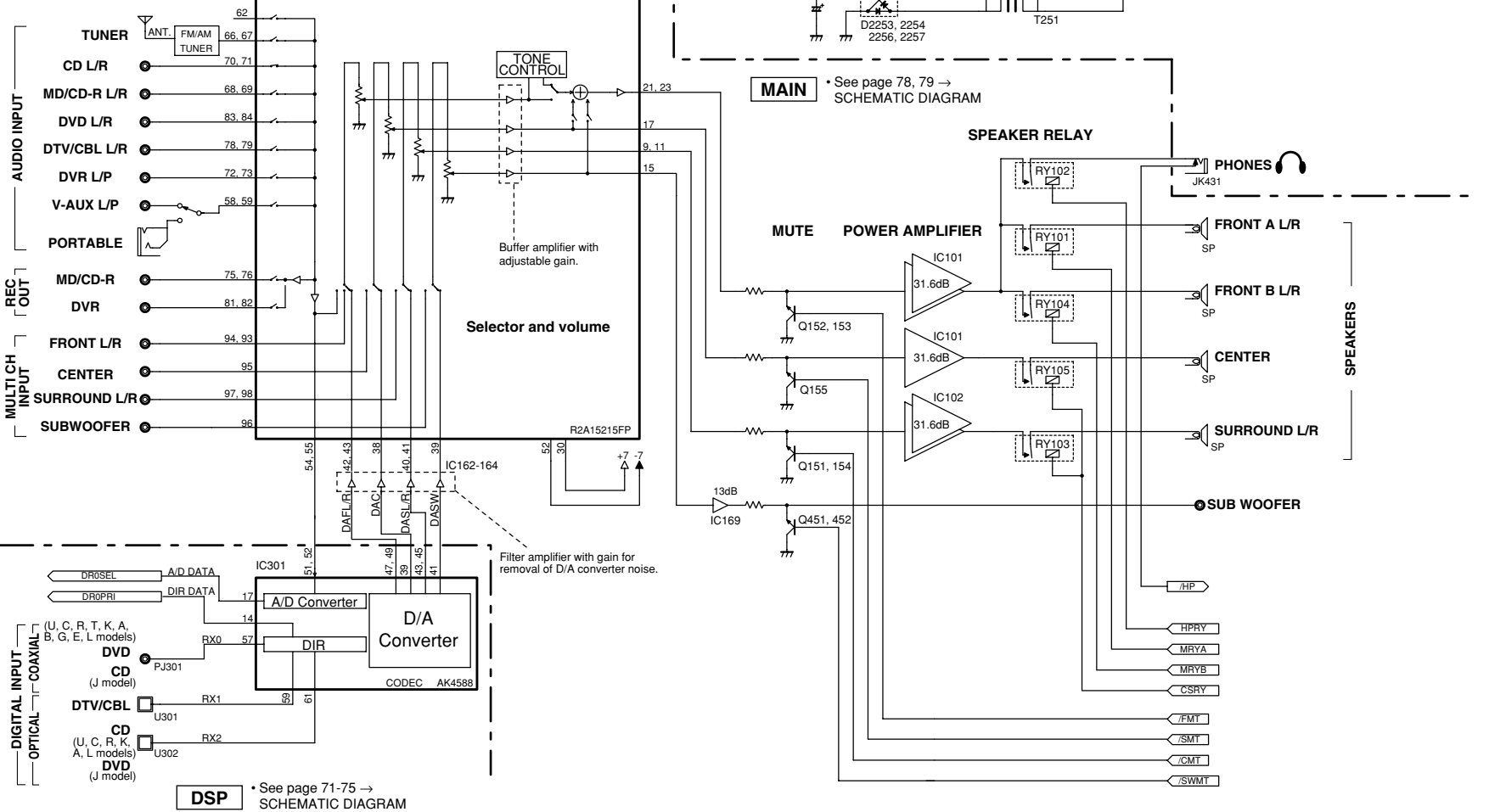

DSP • See page 71-75 → SCHEMATIC DIAGRAM

Control Section

OPERATION • See page 76, 77 → SCHEMATIC DIAGRAM

DSP

• See page 71-75 → SCHEMATIC DIAGRAM

CONTROL LIST	
Input select	VIA, VIB, /VR1, SSEL1-3
Control bus	SPISSEL3-5, /CCBE, /IC_AK
A/D select	ADSELO-2
Speaker relay control	MRYA, MRVB, CSRY, HPRY
Mute control	/FMT, /CMT, /SMT, /SWMT
Power control	PRY, /BohmSW, /3.3SW
XM control (U, C models)	CLKSEL
RDS control (B, G, E models)	RDS_RST

INPUT LIST	
Protection	PDET, PRD, PRV, PLDET, THM
Keypad	KEY0, KEY1
Hi or Lo	PRI, /HP, /ST, TUNED, ANT_REV, XM_MUTE, LINKACTIVE
else	DEST

(U, C models)

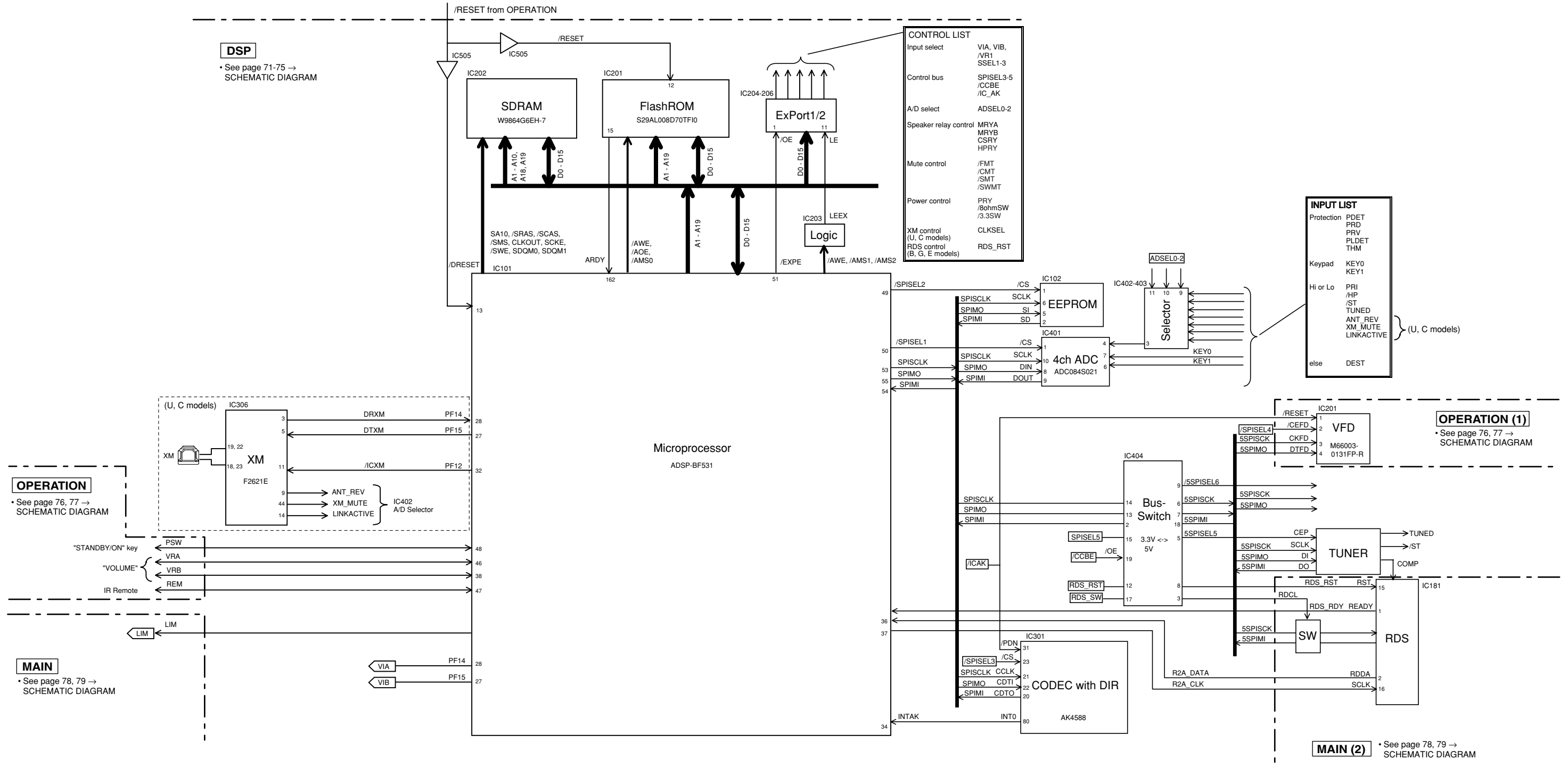

OPERATION • See page 76, 77 → SCHEMATIC DIAGRAM

MAIN • See page 78, 79 → SCHEMATIC DIAGRAM

MAIN (2) • See page 78, 79 → SCHEMATIC DIAGRAM

PIN CONNECTION DIAGRAMS

ICs

<p>ADC084S021 CIMM</p>	<p>ADSP-BF531 CPU</p>	<p>AK4588VQ</p>	<p>AZ4580MTR-E1</p>
<p>BR25L320F-W EEPROM</p>	<p>F2621E-01-TR</p>	<p>KIA7805API KIA7812API</p>	<p>KIA79M05PI KIA7912PI</p>
<p>LM61CIZ</p>	<p>LA7956</p>	<p>LC72725KM</p>	<p>M66003-0131FP-R</p>
<p>NJM2586AM</p>	<p>NJM2388F05 NJM2388F33</p> <p>1. VIN 2. VOUT 3. GND 4. ON/OFF CONTROL</p>	<p>NJM2581M</p>	<p>R2A15215FP</p>
<p>S29AL008D70TFI0</p>	<p>SN74AHC02PWR SN74AHC08PWR SN74LV08APWR SN74LVU04APWR</p>	<p>SN74AHCT245PWR SN74LV573APWR</p>	<p>SN74LV157APWR SN74LV4051APWR</p>
<p>STK433-130-E</p>	<p>STK433-330-E</p>	<p>TC74HC4052AF</p>	<p>W9864G6EH</p>

Diodes

<p>1SS133, 176 1SS270A 1T2 MTZJ4.7A</p>	<p>RB160L-40 TE25</p>	<p>MA8075-H MA8100-H</p>	<p>KDS160-RTK</p>
<p>KBP103G 1.0A 200V</p>	<p>1SS355 RB500V-40 UDZ3.6BTE-17 UDZ5.1B UDZS3.3BTE-17 UDZS5.6BTE-17 UDZS9.1B</p>	<p>RS403M</p>	<p>TS6P03G 6.0A 200V</p>

Transistors

<p>2SA1015 2N5401C 2N5551C</p>	<p>2SA1037K 2SC2412K 2SC3326 2SD1938F</p>	<p>2SA1708</p>	<p>2SB1274</p>	<p>2SC1740S</p>
<p>2SC1815 2SC2705</p>	<p>KRC102M-AT</p> <p>1. COMMON 2. OUT (COLLECTOR) 3. IN (BASE)</p>	<p>KRA102S-RTK/P KRA104S-RTK KRC102S-RTK KRC104S-RTK</p>	<p>RTQ040P02</p> <p>1. Drain 2. Drain 3. Gate 4. Source 5. Drain 6. Drain</p>	

PRINTED CIRCUIT BOARDS

DSP P.C.B. (Side A)

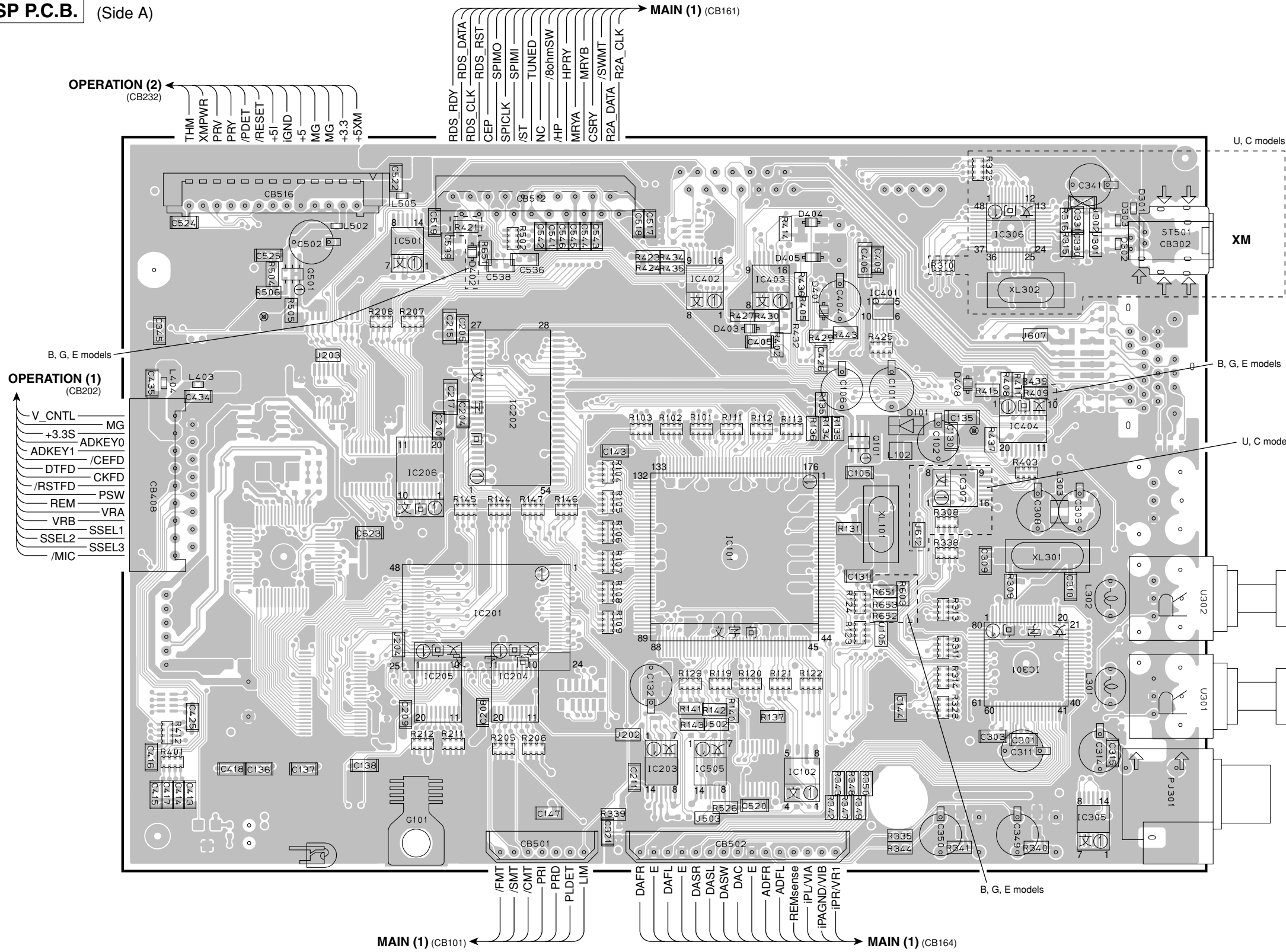

Semiconductor Location

Ref no.	Location	Ref no.	Location
D101	G4	IC204	D5
D301	H3	IC205	D5
D302	H3	IC206	D4
D303	H3	IC301	G5
D401	F3	IC305	H6
D402	D3	IC306	G3
D403	F3	IC307	G4
D404	F3	IC401	F3
D405	F3	IC402	E3
D408	G4	IC403	F3
IC101	F5	IC404	G4
IC102	F6	IC501	D3
IC201	D5	IC505	E6
IC202	D4	Q101	F4
IC203	E6	Q501	C3

DSP P.C.B. (Side B)

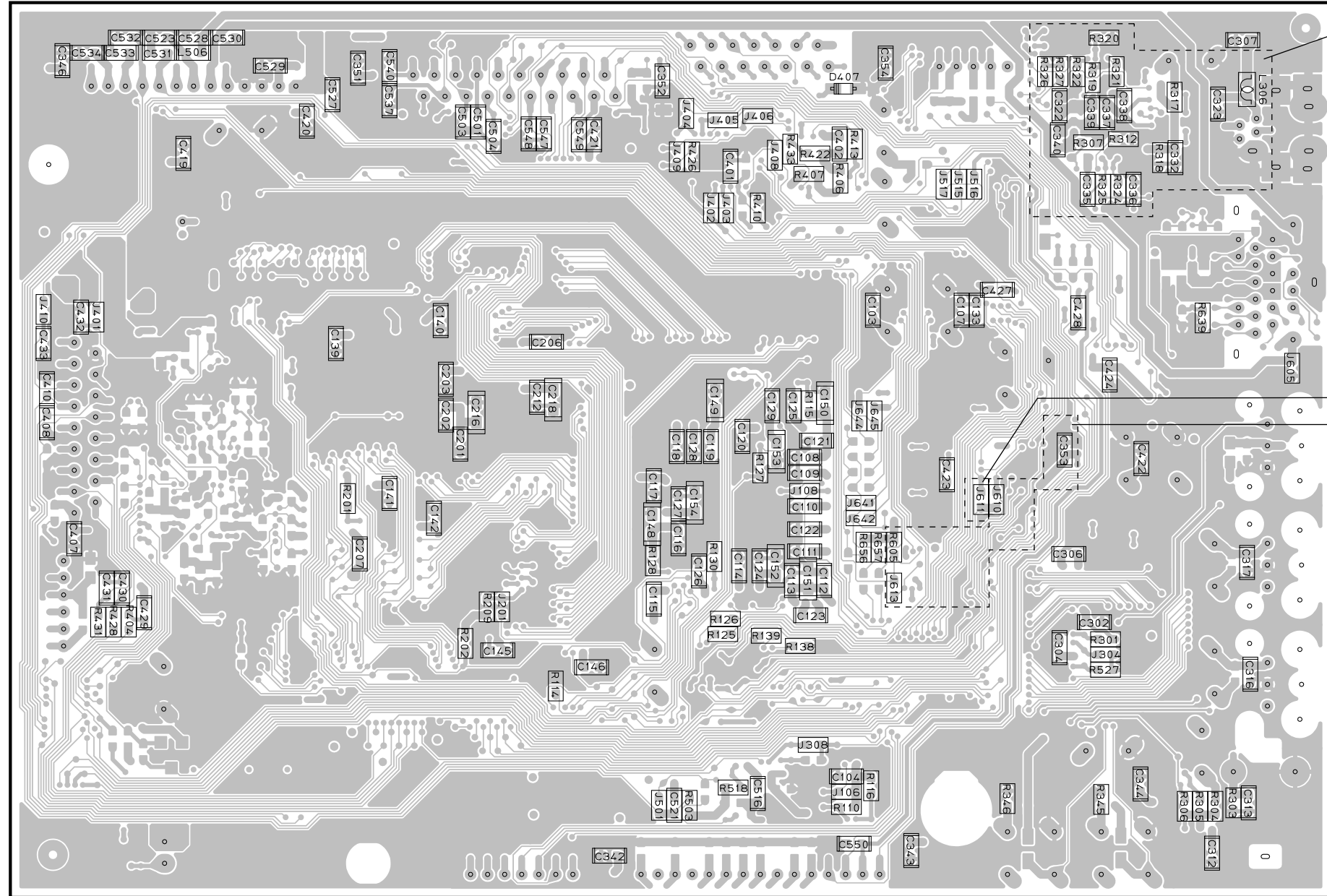

U, C models

B, G, E models
U, C models

• **Semiconductor Location**

Ref no.	Location
D407	F3

1
2
3
4
5
6
7

OPERATION (1) P.C.B. (Side A)

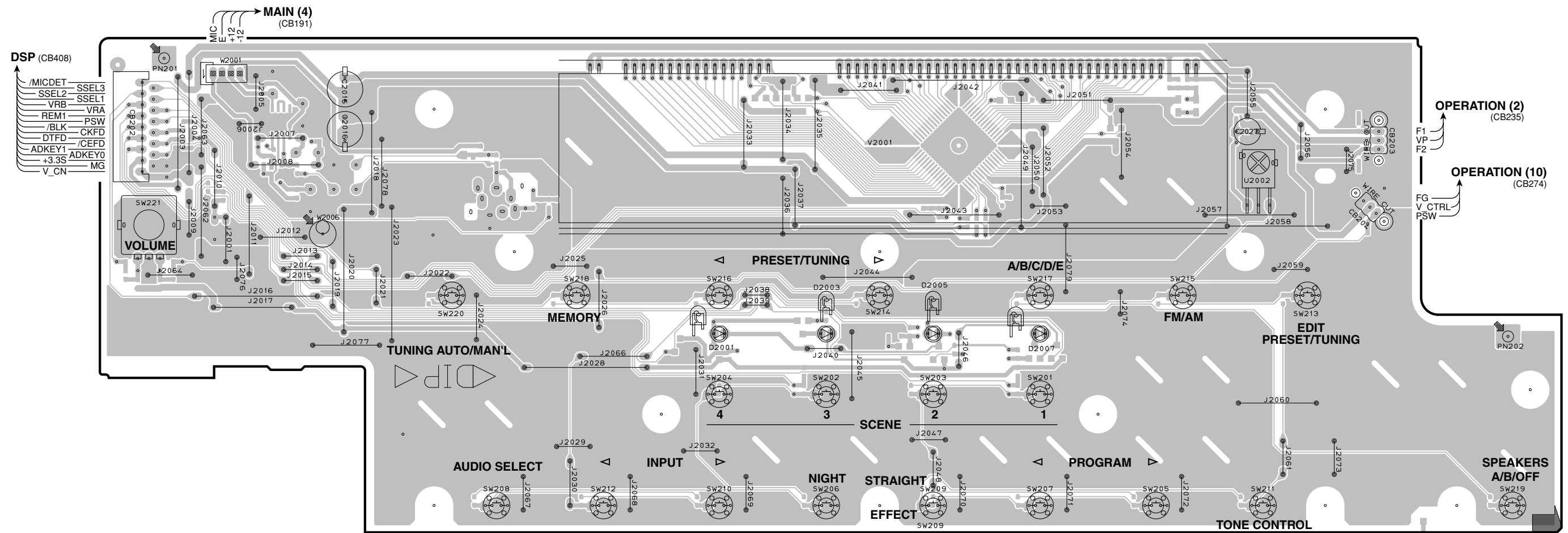

OPERATION (2)
(CB235)

OPERATION (10)
(CB274)

F1
VP
F2
FG
V CTRL
PSW

• **Semiconductor Location**

Ref no.	Location
D2001	E4
D2003	F4
D2005	F4
D2007	G4

OPERATION (1) P.C.B. (Side B)

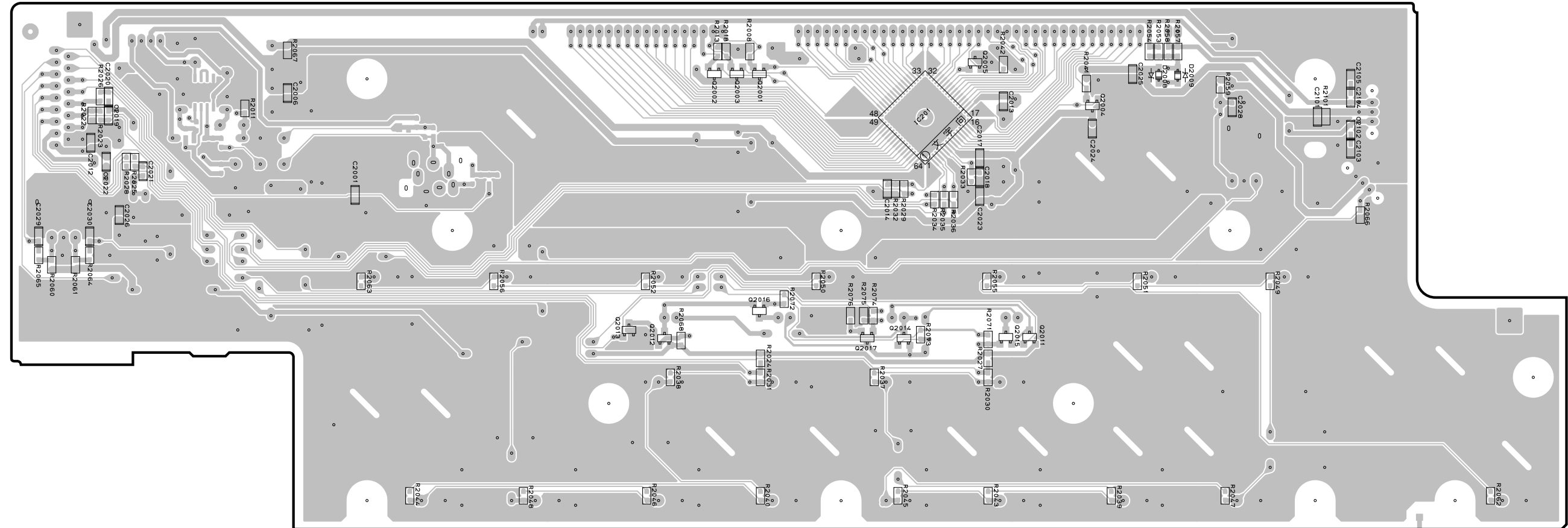

• **Semiconductor Location**

Ref no.	Location	Ref no.	Location
D2008	H3	Q2011	G4
D2009	H3	Q2012	E4
IC201	G3	Q2013	E4
Q2001	F3	Q2014	G4
Q2002	F3	Q2015	G4
Q2003	F3	Q2016	F4
Q2004	H3	Q2017	F4
Q2005	G3		

OPERATION (2) P.C.B. (Side A)

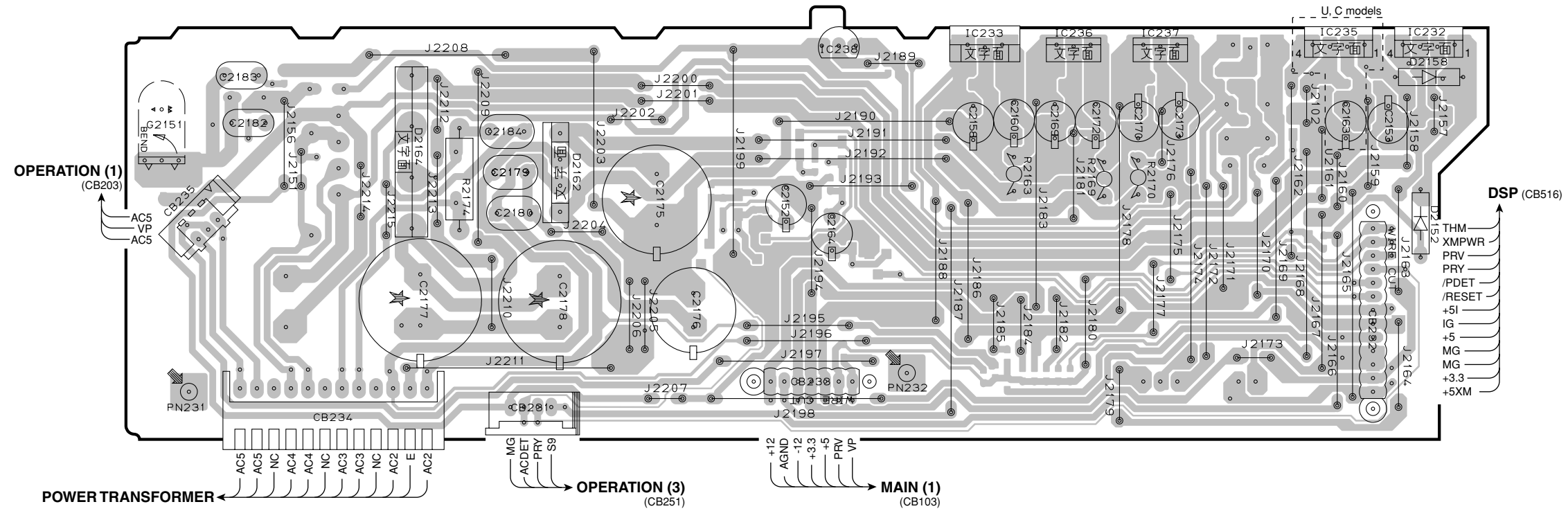

• Semiconductor Location

Ref no.	Location
D2152	H4
D2158	H3
D2162	D3
D2164	C3
IC232	H3
IC233	F3
IC235	H3
IC236	F3
IC237	G3
IC238	E3

Circuit No.	U, C	R, T, K, A, B, G, E, L, J
C2177	O	X
J2102	X	O

X : NOT USED
O : USED/APPLICABLE

OPERATION (2) P.C.B. (Side B)

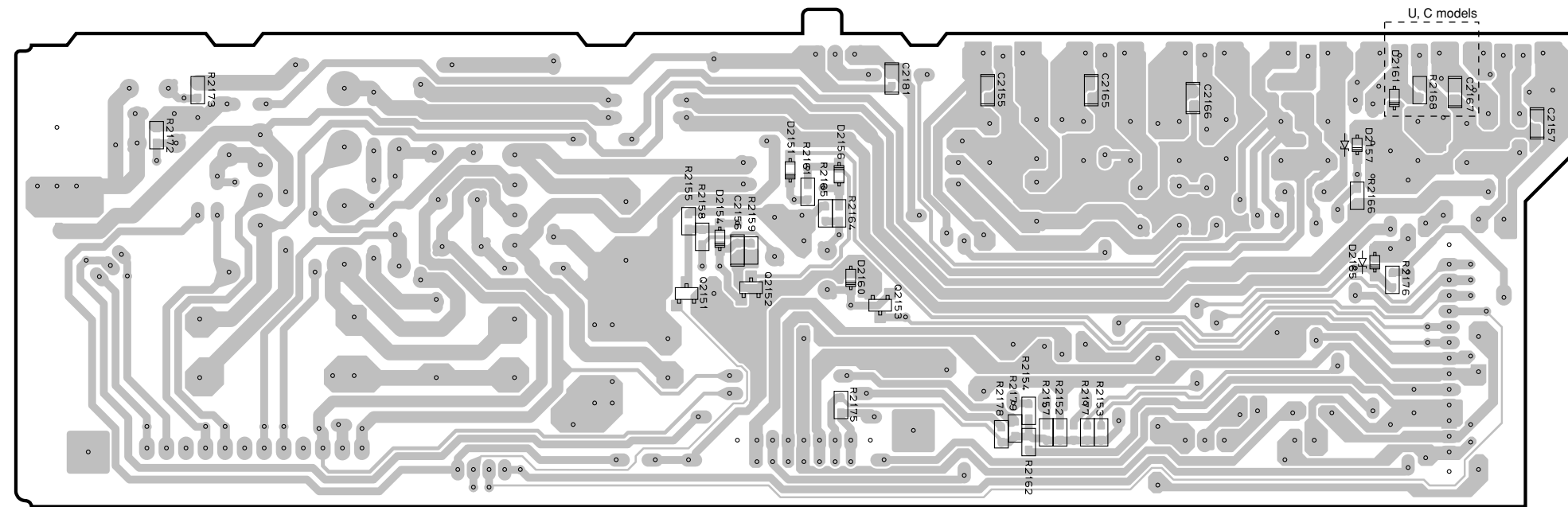

• Semiconductor Location

Ref no.	Location
D2151	E3
D2154	E4
D2156	E3
D2157	G3
D2160	E4
D2161	H3
D2165	G4
Q2151	E4
Q2152	E4
Q2153	E4

OPERATION (3) P.C.B. (Side A)

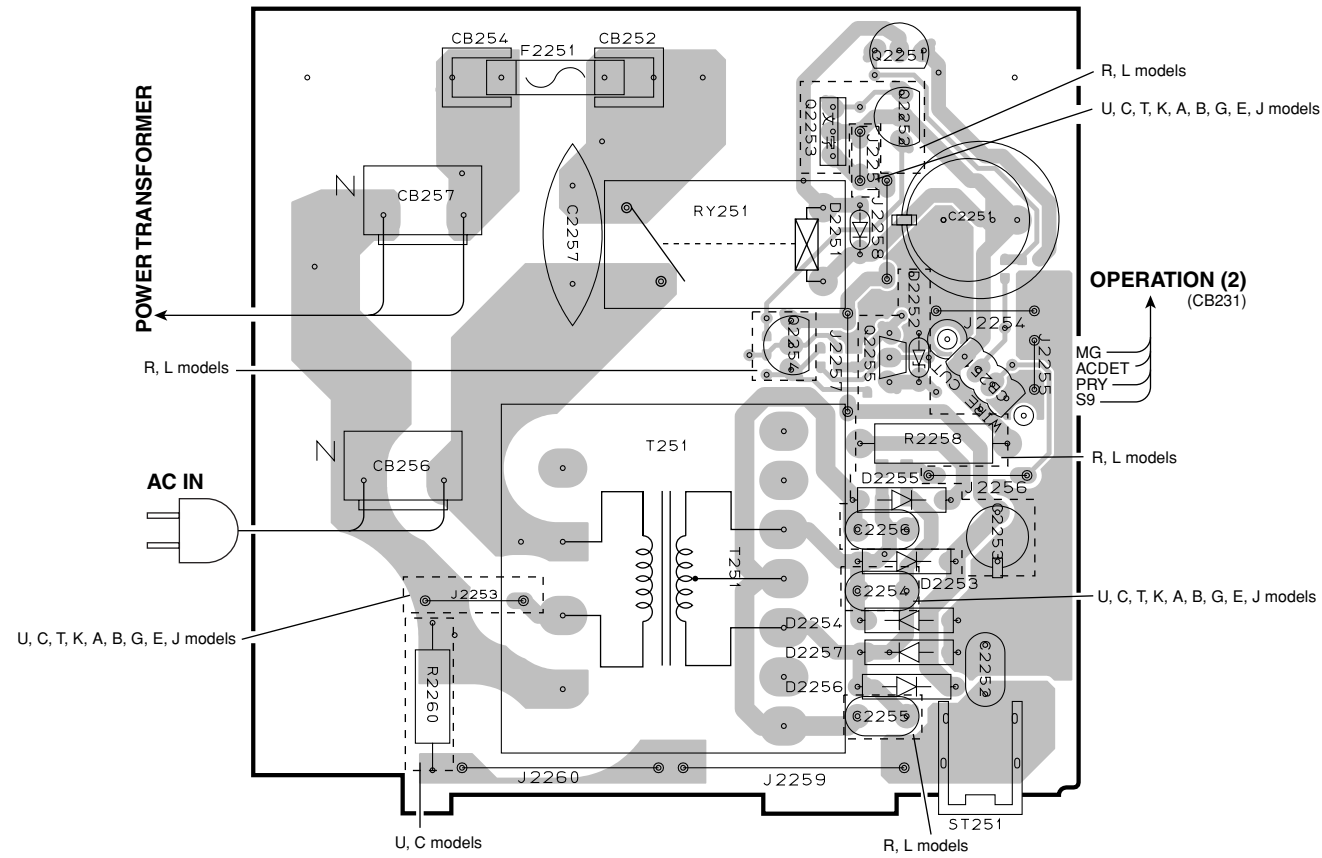

OPERATION (3) P.C.B. (Side B)

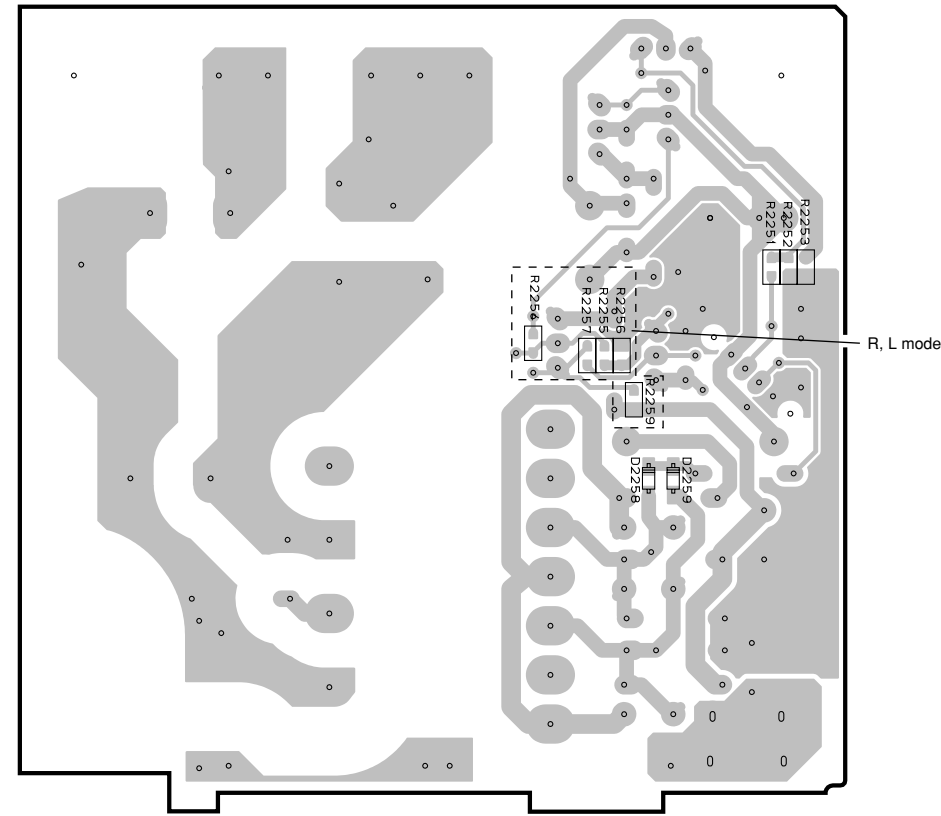

• **Semiconductor Location**

Ref no.	Location
D2251	D2
D2252	D3
D2253	D3
D2254	D4
D2255	D3
D2256	D4
D2257	D4
D2258	H3
D2259	H3
D2301	I6
D2302	I6
D2303	I6
Q2251	D2
Q2252	D2
Q2253	D2
Q2254	C3
Q2255	D3

OPERATION (5) P.C.B. (Side A)

R, L models

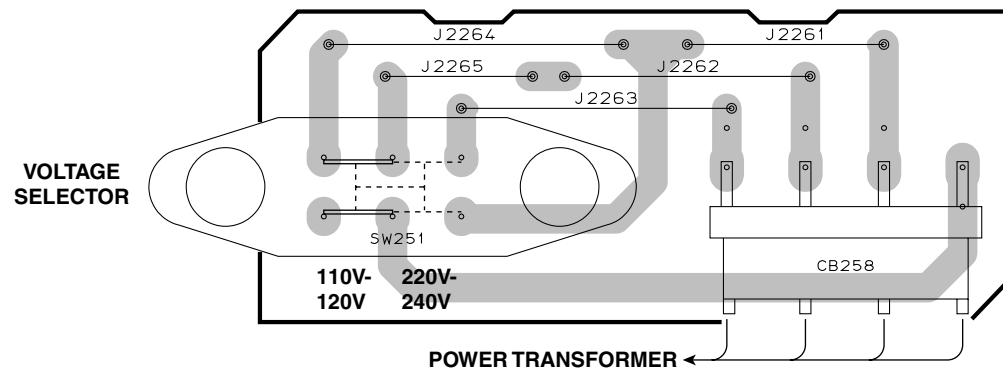

OPERATION (6) P.C.B. (Side A)

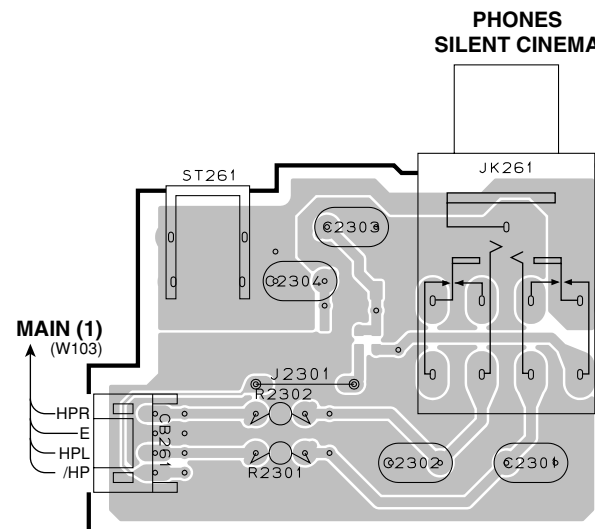

OPERATION (6) P.C.B. (Side B)

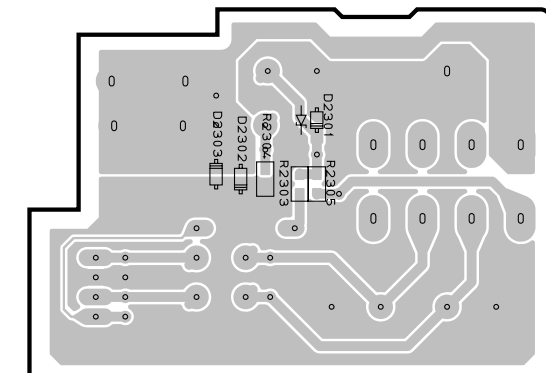

1
2
3
4
5
6
7

OPERATION (7) P.C.B. (Side A)

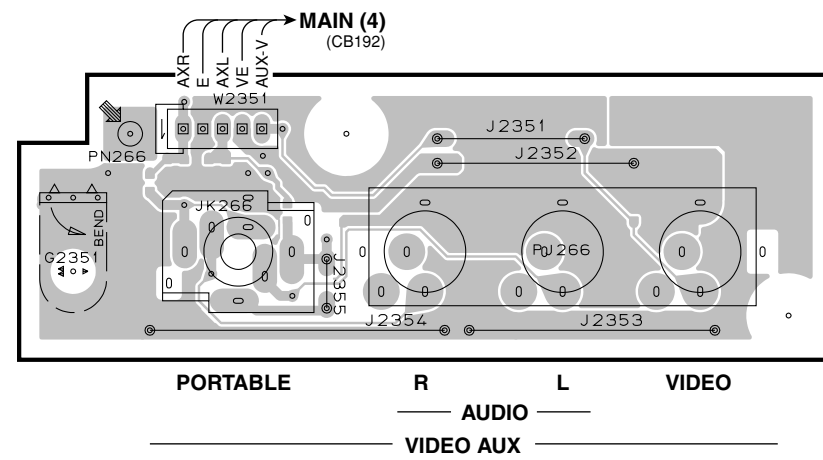

OPERATION (10) P.C.B. (Side A)

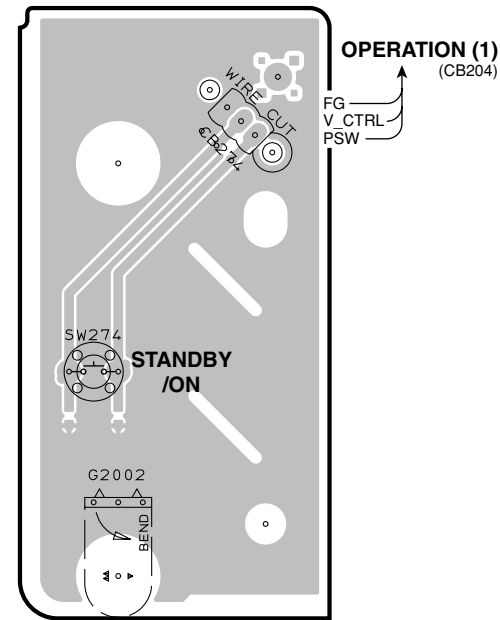

• **Semiconductor Location**

Ref no.	Location
D2351	D6
D2352	D6
D2353	C6
D2354	C6

OPERATION (7) P.C.B. (Side B)

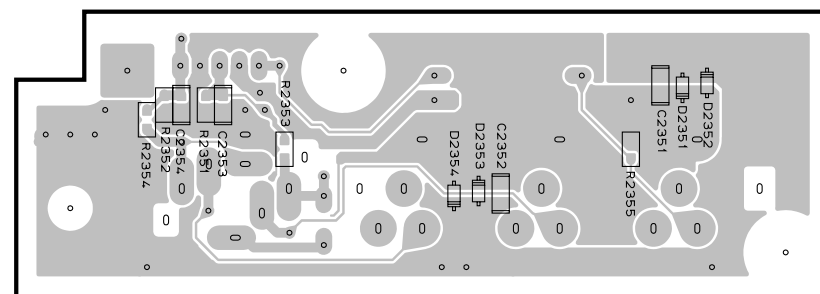

OPERATION (11) P.C.B. (Side A)

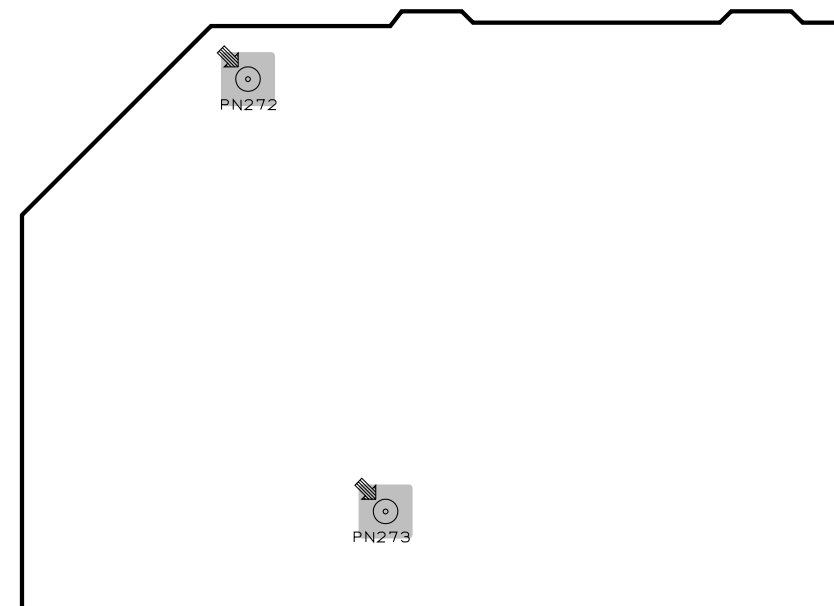

MAIN (1) P.C.B. (Side A)

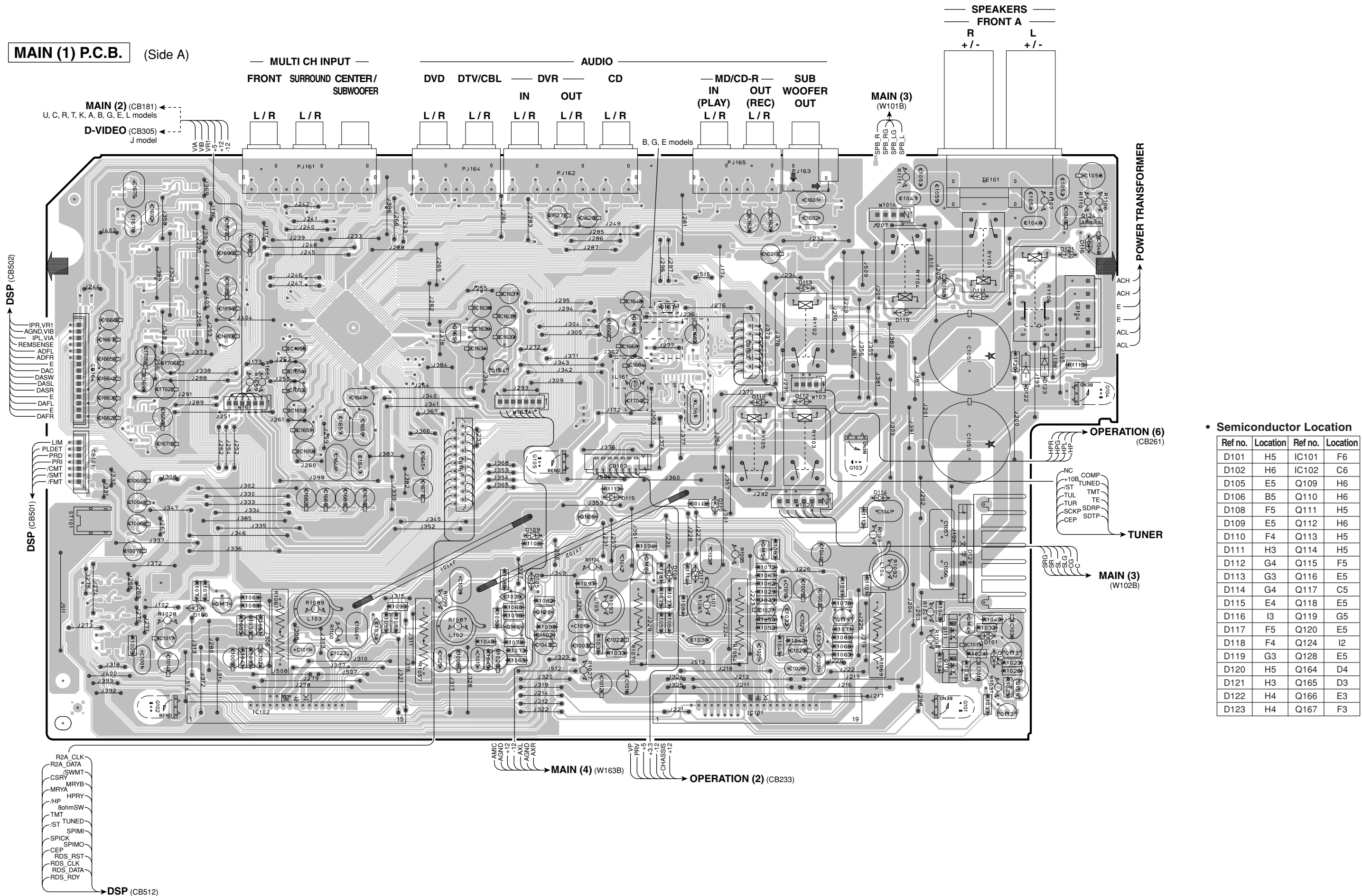

• Semiconductor Location

Ref no.	Location	Ref no.	Location
D101	H5	IC101	F6
D102	H6	IC102	C6
D105	E5	Q109	H6
D106	B5	Q110	H6
D108	F5	Q111	H5
D109	E5	Q112	H6
D110	F4	Q113	H5
D111	H3	Q114	H5
D112	G4	Q115	F5
D113	G3	Q116	E5
D114	G4	Q117	C5
D115	E4	Q118	E5
D116	I3	Q119	G5
D117	F5	Q120	E5
D118	F4	Q124	I2
D119	G3	Q128	E5
D120	H5	Q164	D4
D121	H3	Q165	D3
D122	H4	Q166	E3
D123	H4	Q167	F3

MAIN (1) P.C.B. (Side B)

B, G, E models

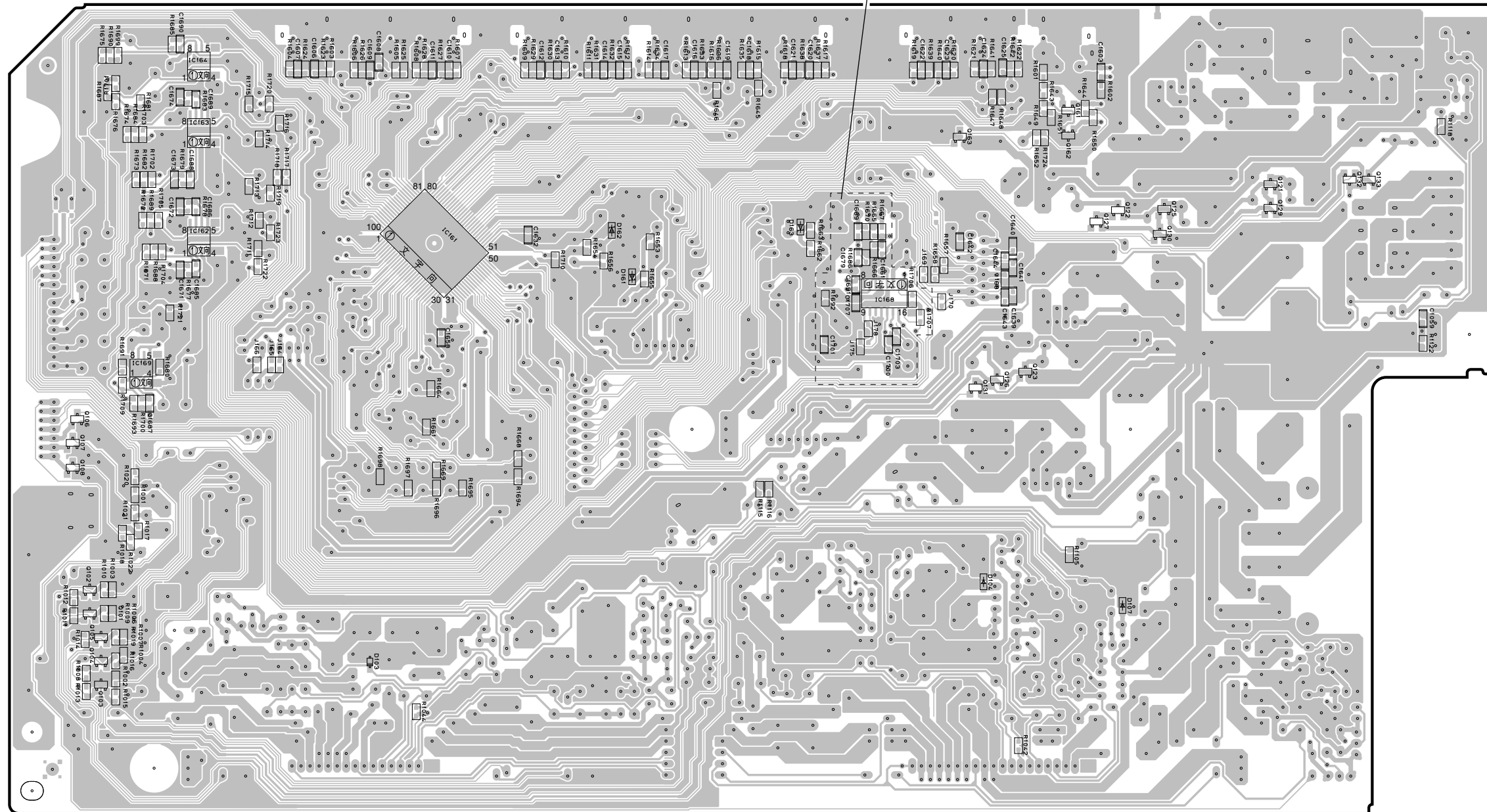

• **Semiconductor Location**

Ref no.	Location	Ref no.	Location
D103	C5	Q106	B4
D104	F5	Q107	B4
D107	G5	Q108	B4
D161	D3	Q121	H3
D162	D3	Q122	G3
D163	E3	Q123	F4
IC161	C3	Q125	G3
IC162	B3	Q126	F4
IC163	B3	Q127	G3
IC164	B2	Q129	H3
IC168	F3	Q130	G3
IC169	B4	Q131	F4
Q101	B5	Q132	H3
Q102	B5	Q133	H3
Q103	B5	Q161	G3
Q104	B5	Q162	G3
Q105	B5	Q163	F3

MAIN (2) P.C.B. (Side A) U, C, R, T, K, A, B, G, E, L models

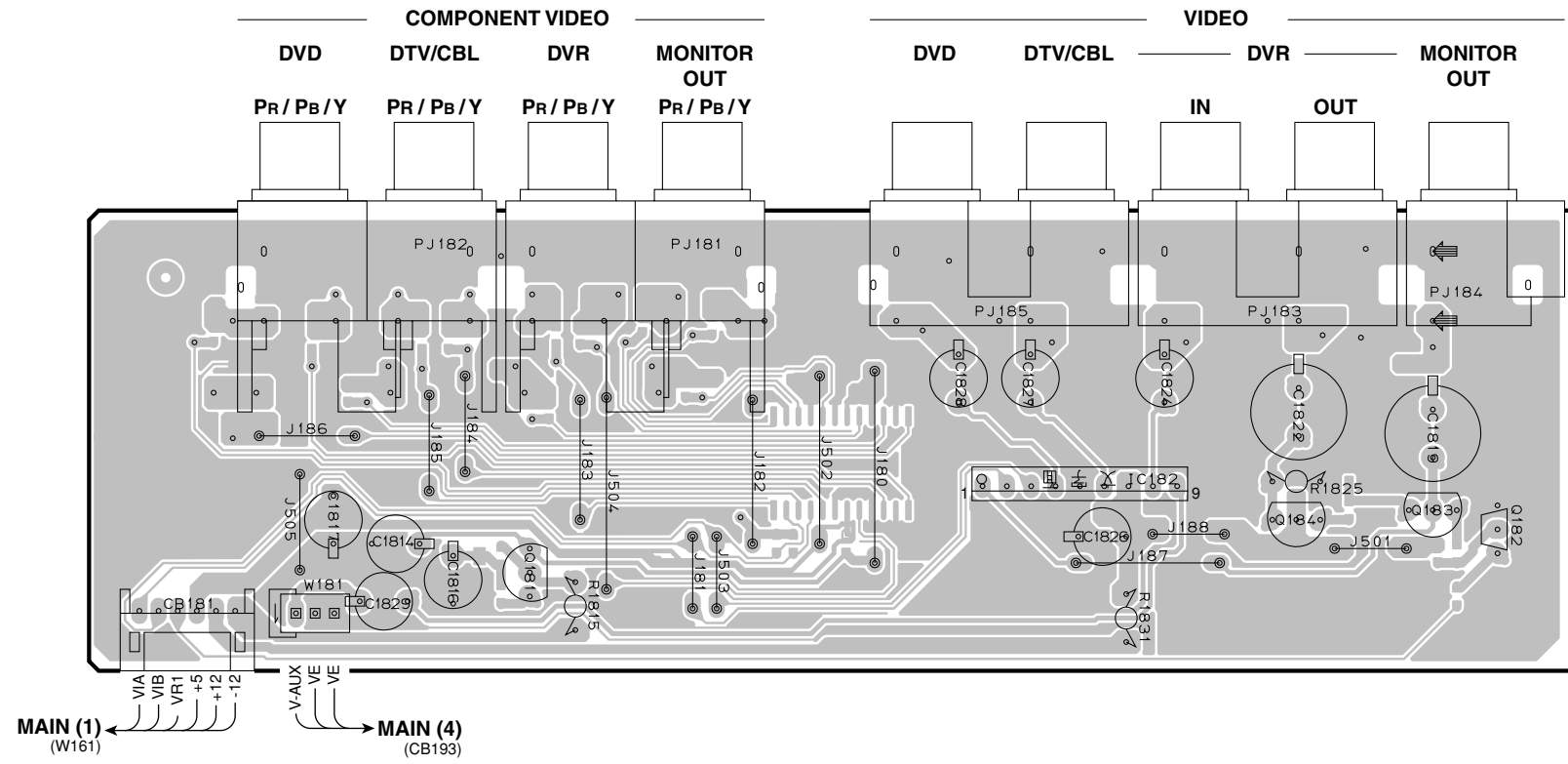

MAIN (2) P.C.B. (Side B) U, C, R, T, K, A, B, G, E, L models

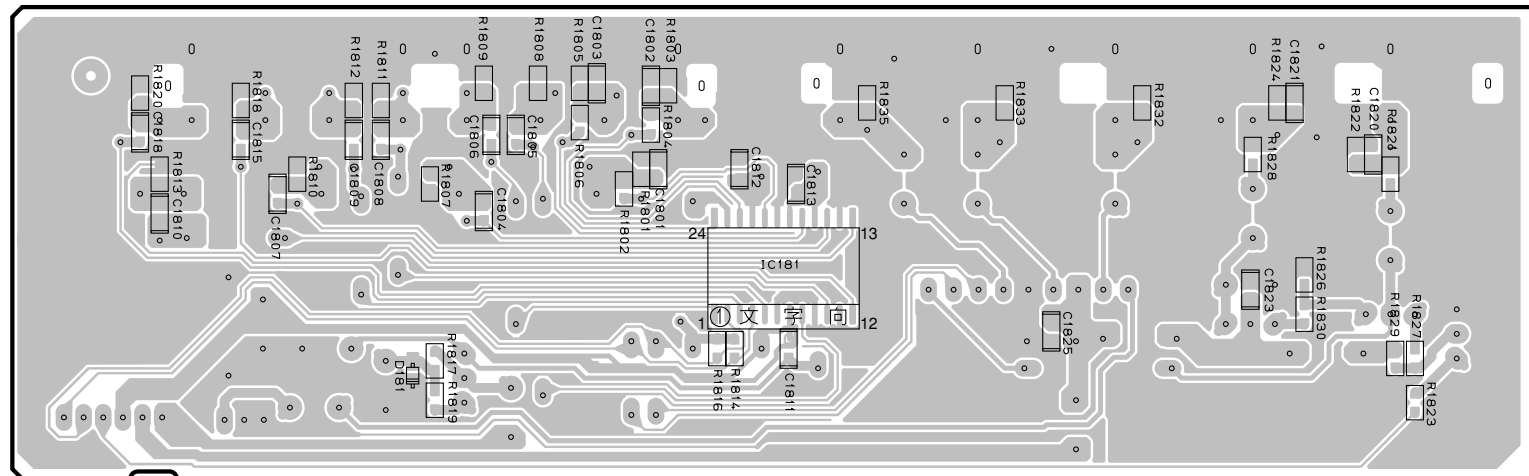

• **Semiconductor Location**

Ref no.	Location
D181	C7
IC181	D6
IC182	E4
Q181	C4
Q182	G4
Q183	G4
Q184	F4

1
2
3
4
5
6
7

MAIN (3) P.C.B. (Side A)

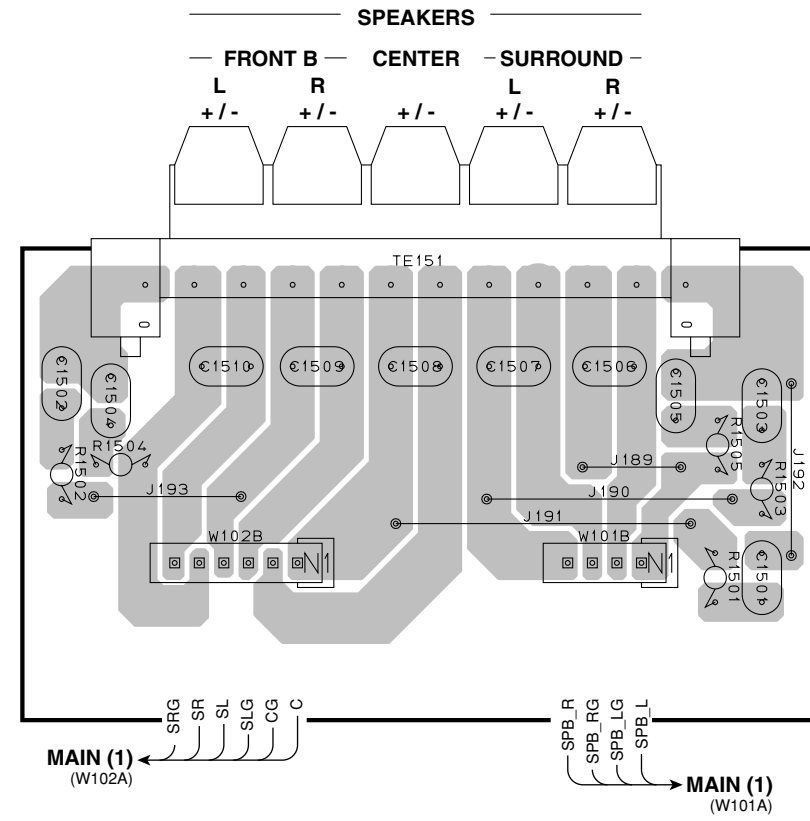

MAIN (4) P.C.B. (Side A)

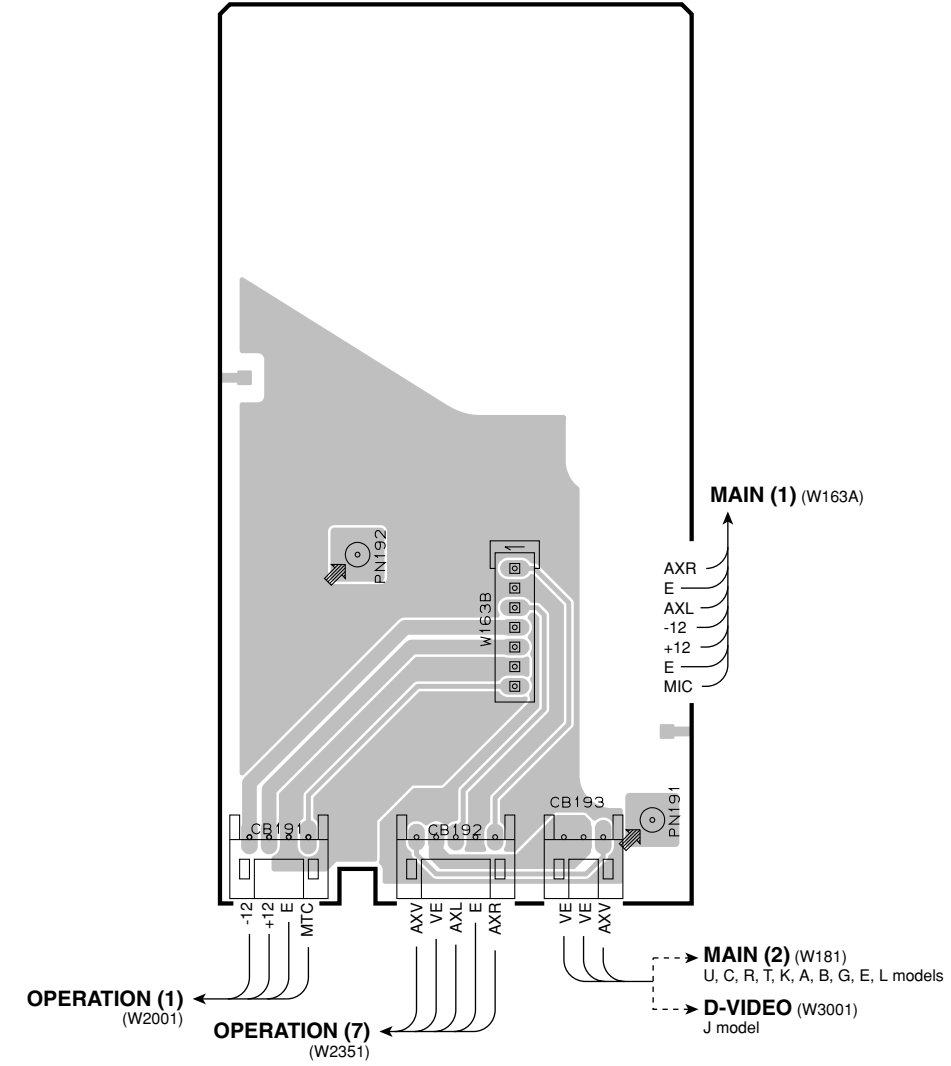

SCHEMATIC DIAGRAMS
DSP 1/5

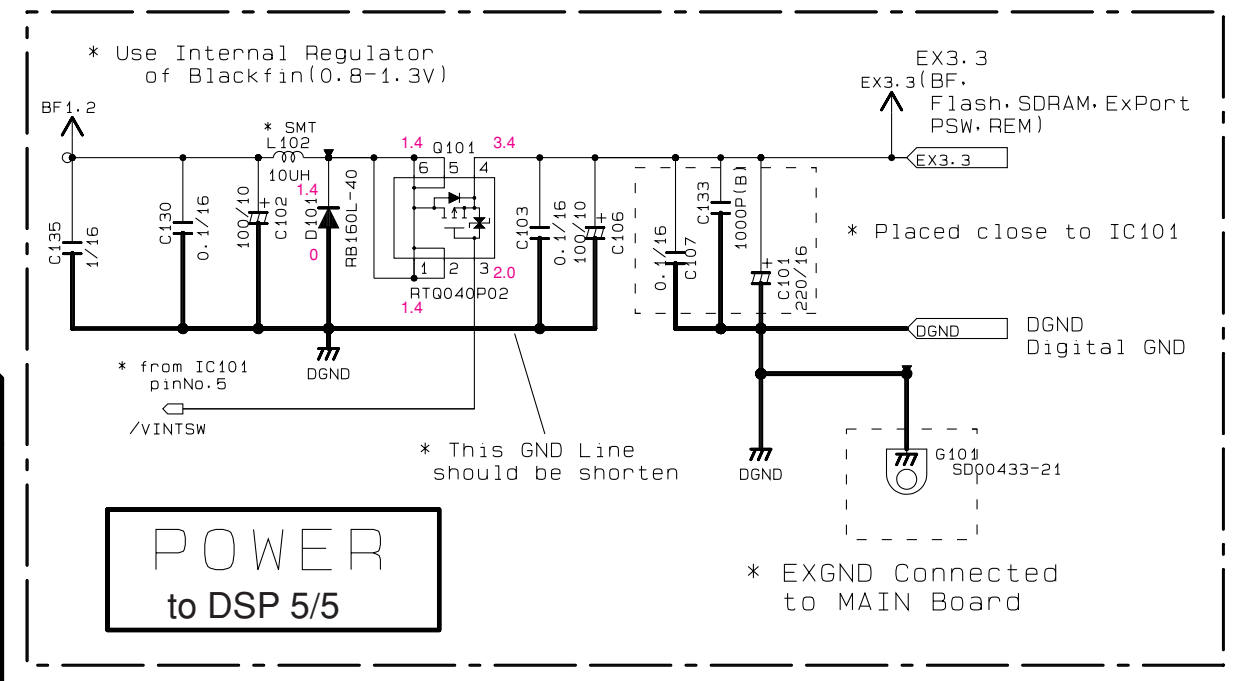
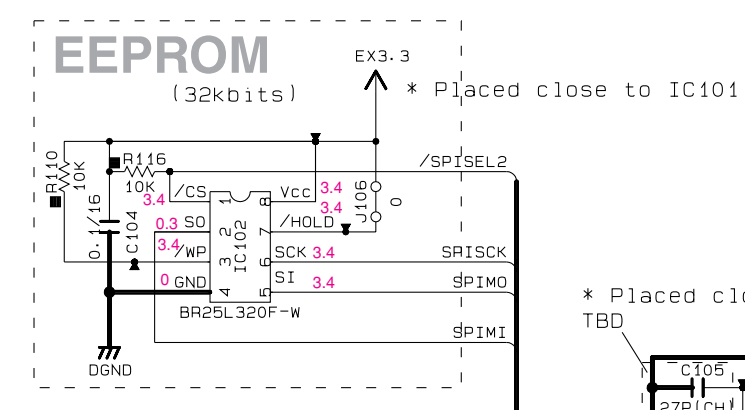
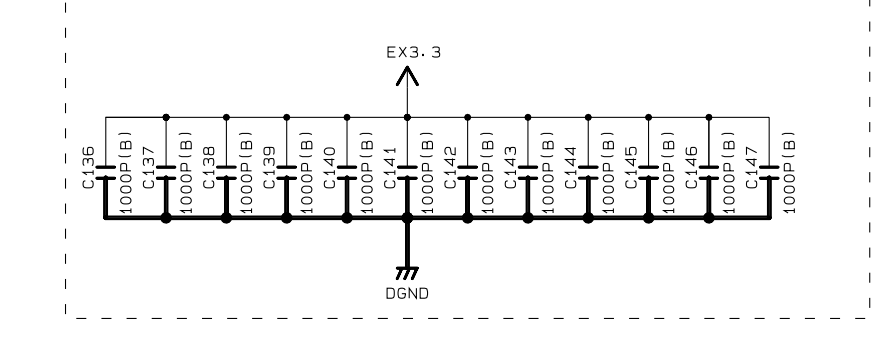
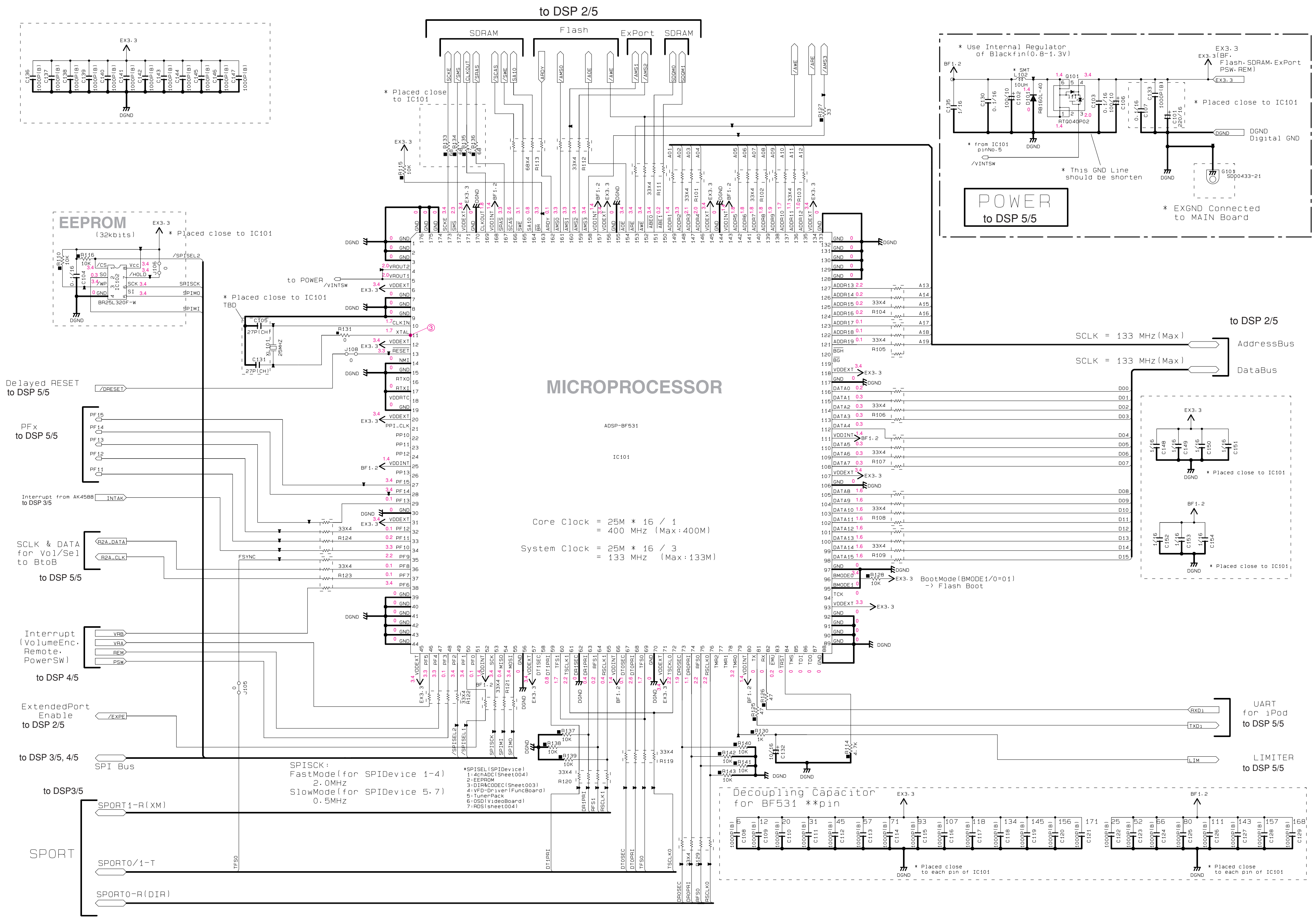

MICROPROCESSOR

ADSP-BF531
IC101

Core Clock = $25\text{M} \times 16 / 1$
= 400 MHz (Max:400M)

System Clock = $25\text{M} \times 16 / 3$
= 133 MHz (Max:133M)

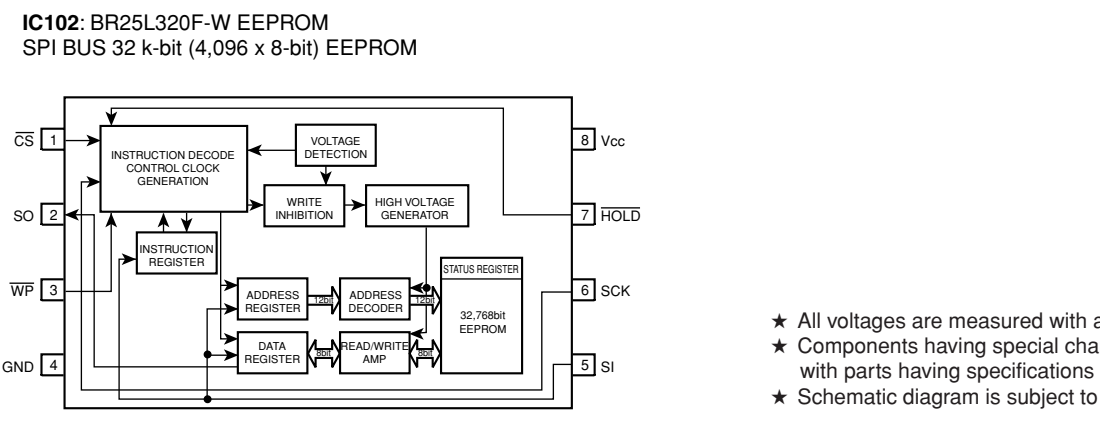
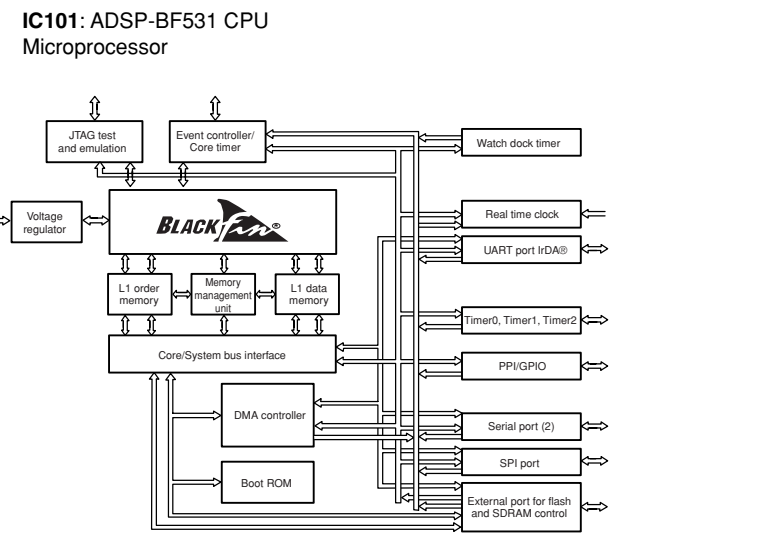

NOTICE (mode1)

(J)..... JAPAN
(U)..... U.S.A
(C)..... CANADA
(T)..... CHINA
(K)..... KOREA
(A)..... AUSTRALIA
(B)..... BRITISH
(L)..... SINGAPORE
(E)..... SOUTH EUROPE
(V)..... TAIWAN

* All voltages are measured with a 10MΩ/V DC electronic voltmeter.
* Components having special characteristics are marked Δ and must be replaced with parts having specifications equal to those originally installed.
* Schematic diagram is subject to change without notice.

● 電圧は、内部抵抗10MΩの電圧計で測定したものです。
● Δ 印のある部品は、安全性確保部品を示しています。部品の交換が必要な場合、パーツリストに記載されている部品を使用してください。
● 本回路図は標準回路図です。改良のため予告なく変更することがございます。

DSP 4/5

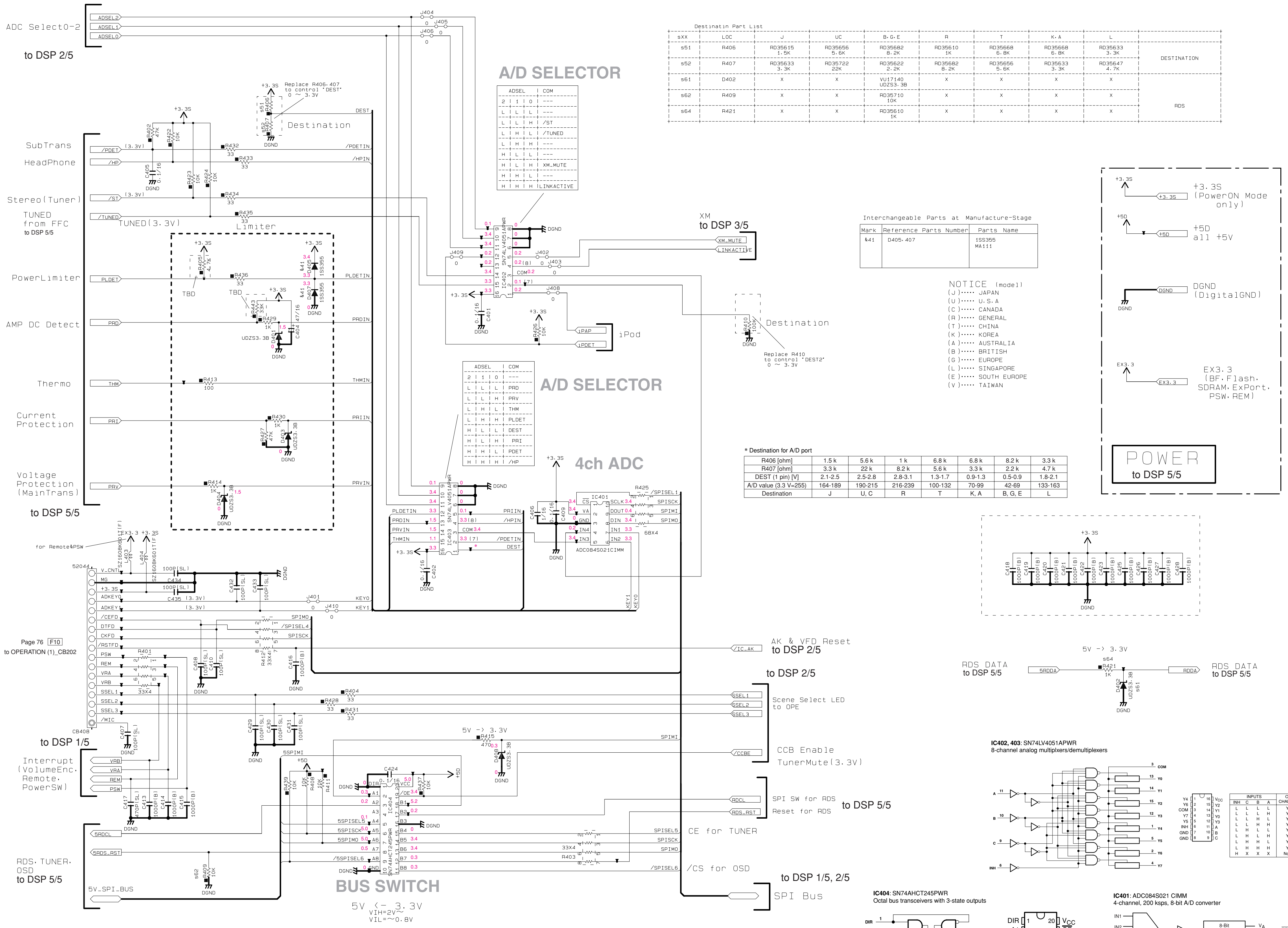

Destination Part List

sXX	LOC	J	UC	B, G, E	R	T	K, A	L	DESTINATION
s51	R405	RD35615 1.5k	RD35655 5.6k	RD35682 8.2k	RD35610 1k	RD35668 6.8k	RD35668 6.8k	RD35633 3.3k	
s52	R407	RD35633 3.3k	RD35722 22k	RD35622 2.2k	RD35682 8.2k	RD35656 5.6k	RD35633 3.3k	RD35647 4.7k	
s61	D402	X	X	VU17140 UDZ53.3B	X	X	X	X	
s62	R409	X	X	RD35710 10k	X	X	X	X	RDS
s64	R421	X	X	RD35610 1k	X	X	X	X	

Interchangeable Parts at Manufacture-Stage

Mark	Reference Parts Number	Parts Name
)	D405-407	1SS395 M4111

NOTICE (model1)
 (J)..... JAPAN
 (U)..... U.S.A
 (C)..... CANADA
 (R)..... GENERAL
 (T)..... CHINA
 (K)..... KOREA
 (A)..... AUSTRALIA
 (B)..... BRITISH
 (G)..... EUROPE
 (L)..... SINGAPORE
 (E)..... SOUTH EUROPE
 (V)..... TAIWAN

* Destination for A/D port

R406 [ohm]	1.5 k	5.6 k	1 k	6.8 k	6.8 k	8.2 k	3.3 k
R407 [ohm]	3.3 k	22 k	8.2 k	5.6 k	3.3 k	2.2 k	4.7 k
DEST (1 pin) [V]	2.1-2.5	2.5-2.8	2.8-3.1	1.3-1.7	0.9-1.3	0.5-0.9	1.8-2.1
A/D value (3.3 V=255)	164-189	190-215	216-239	100-132	70-99	42-69	133-163
Destination	J	U, C	R	T	K, A	B, G, E	L

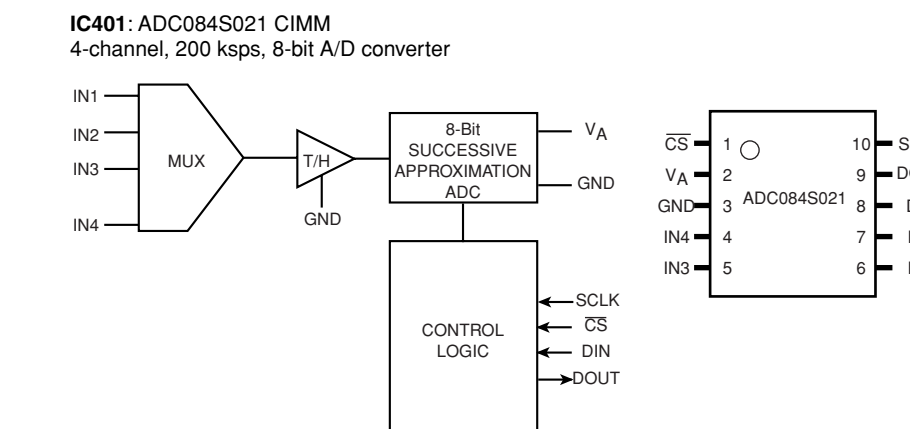
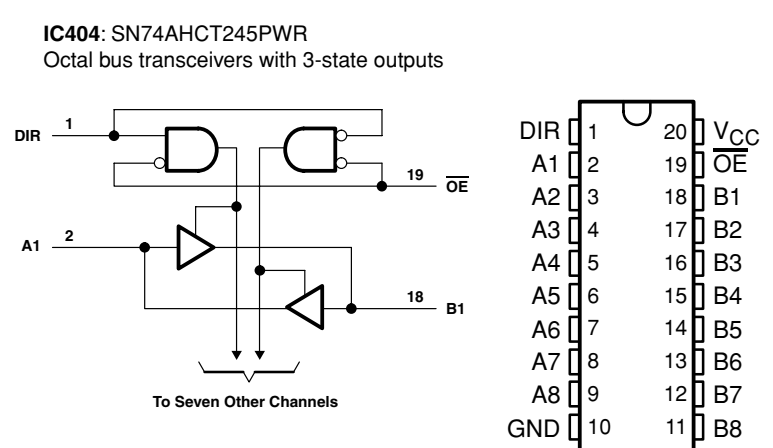
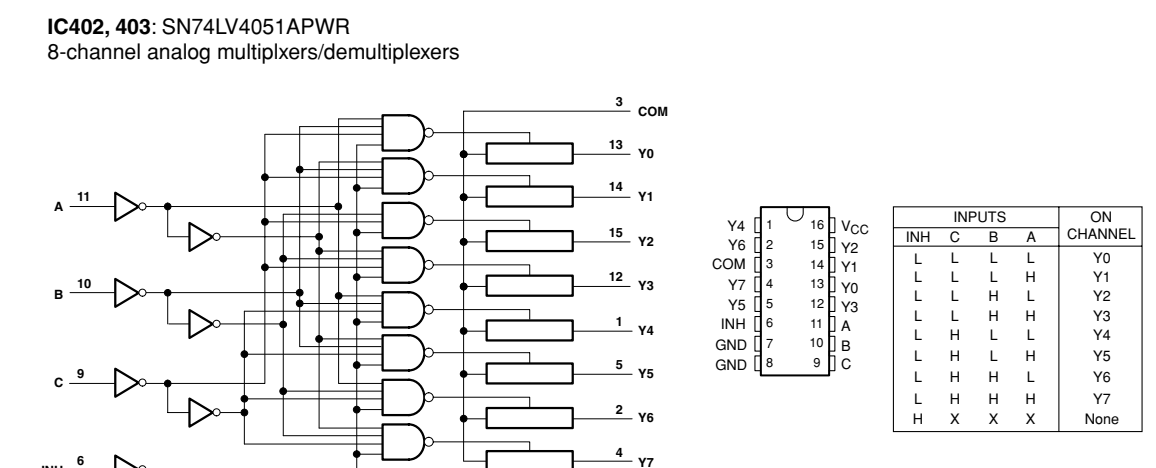
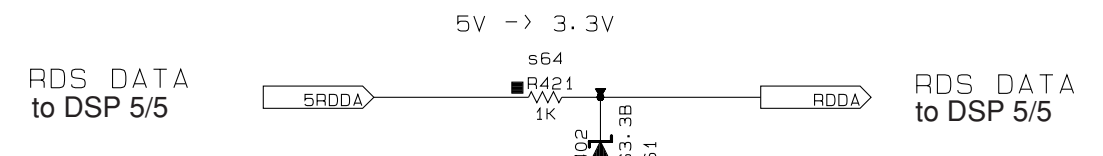
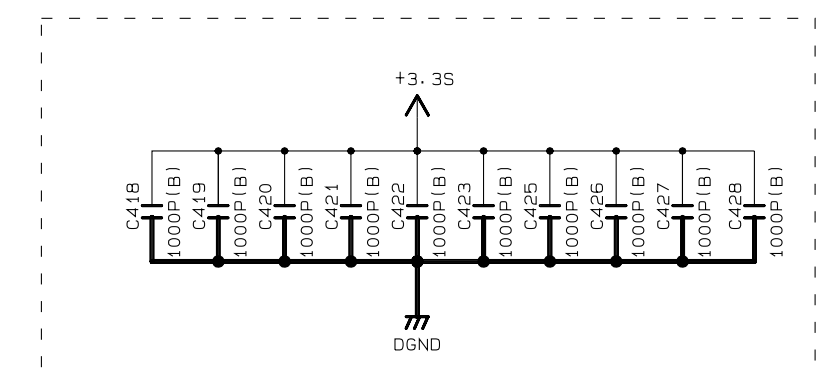
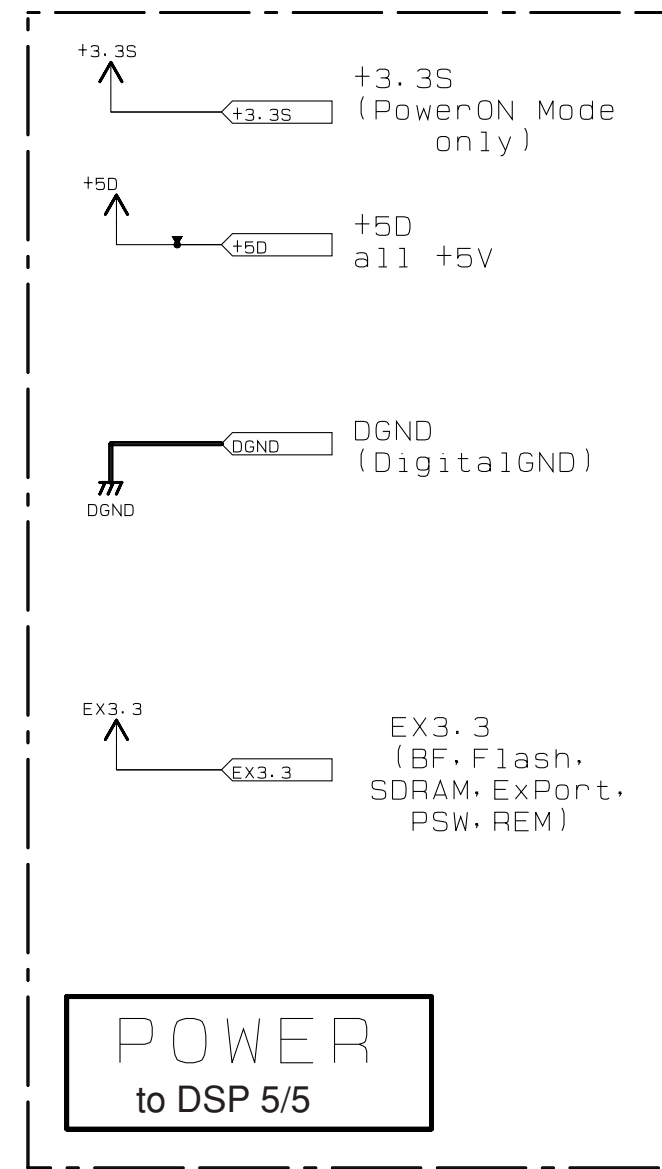

* All voltages are measured with a 10MΩ/V DC electronic voltmeter.
 * Components having special characteristics are marked 1 and must be replaced with parts having specifications equal to those originally installed.
 * Schematic diagram is subject to change without notice.

● 電圧は、内部抵抗10MΩの電圧計で測定したものです。
 ● 1印のある部品は、安全性確保部品を示しています。部品の交換が必要な場合、パーツリストに記載されている部品を使用してください。
 ● 本回路図は標準回路図です。改良のため予告なく変更することがございます。

DSP 5/5

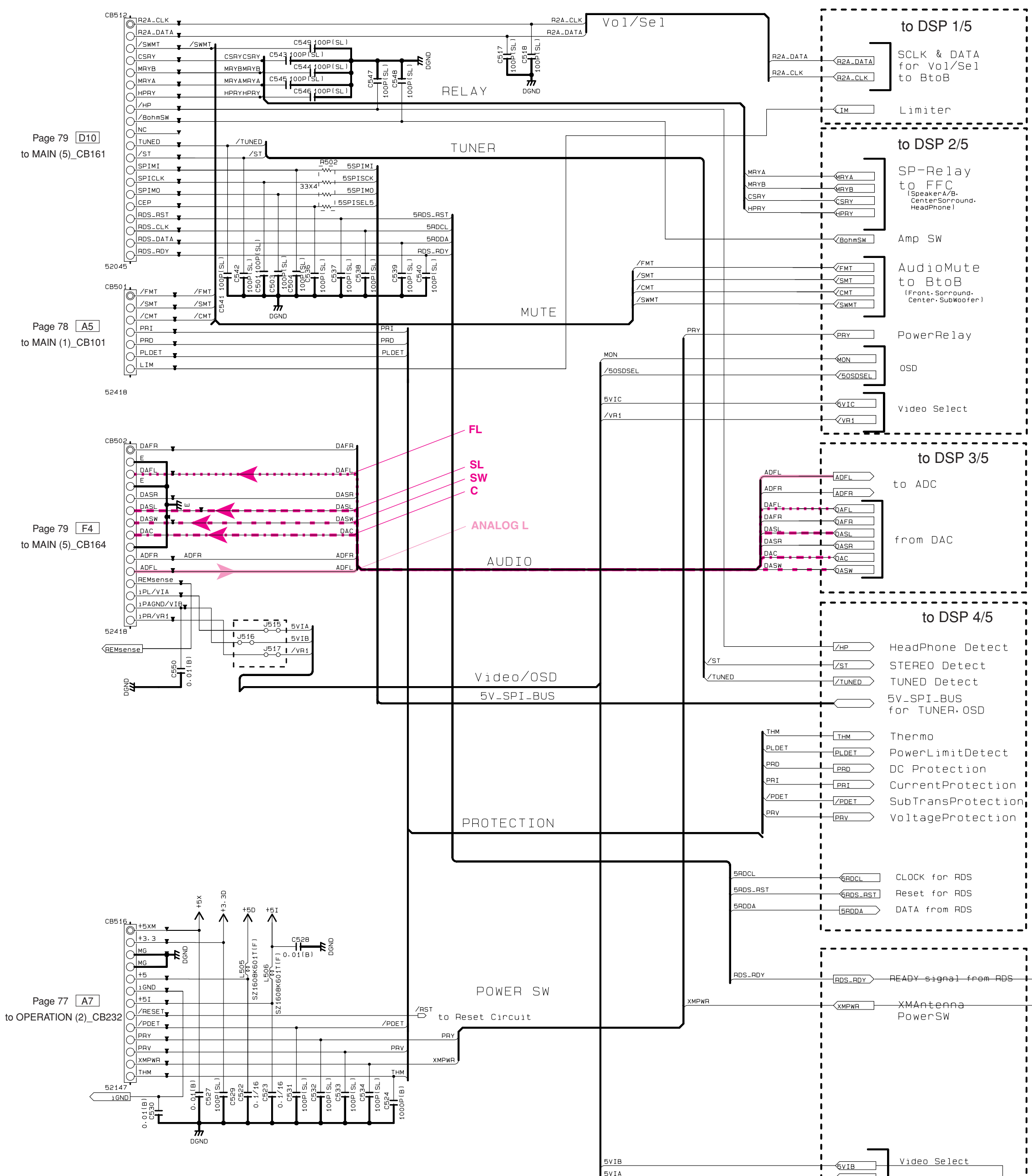

Page 79 [D10]
to MAIN (5)_CB161

Page 78 [A5]
to MAIN (1)_CB101

Page 79 [F4]
to MAIN (5)_CB164

Page 77 [A7]
to OPERATION (2)_CB232

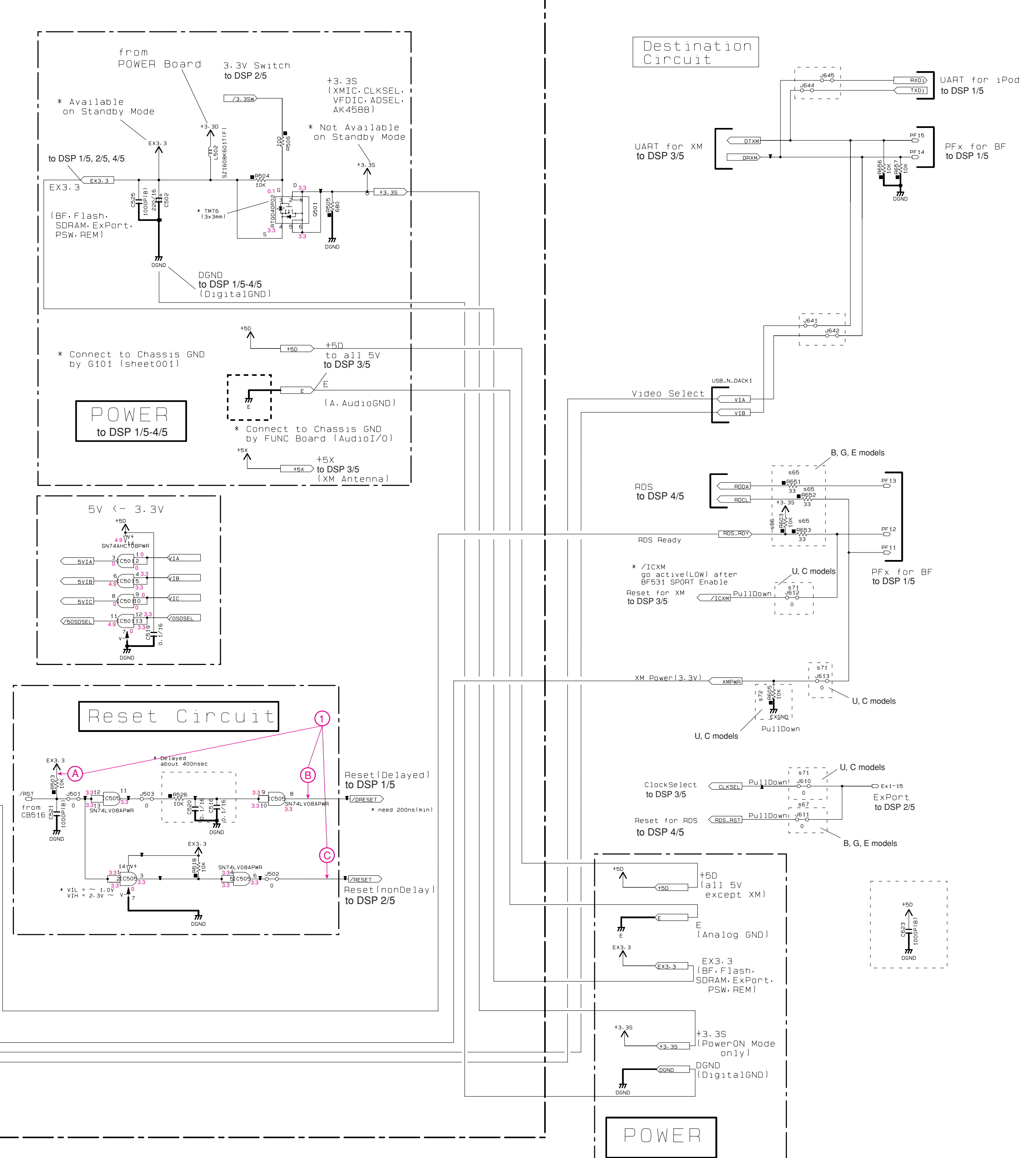

Destination Part List

SXX	LOC	J	UC	B-G-E	R	T	K-A	L
855	R651 R652 R653	X	X	R035433 33	X	X	X	
856	R603	X	X	R036710 10K	X	X	X	
867	J611	X	X	R035000	X	X	X	
871	J612 J613 J610	X	X	R035000	X	X	X	
872	R605	X	X	R036710 10K	X	X	X	XM

IC501: SN74AHC08PWR
Quadruple 2-input positive-AND gates

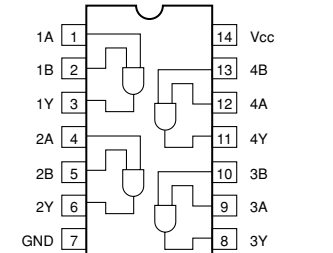

IC505: SN74LV08APWR
Quadruple 2-input positive-AND gate

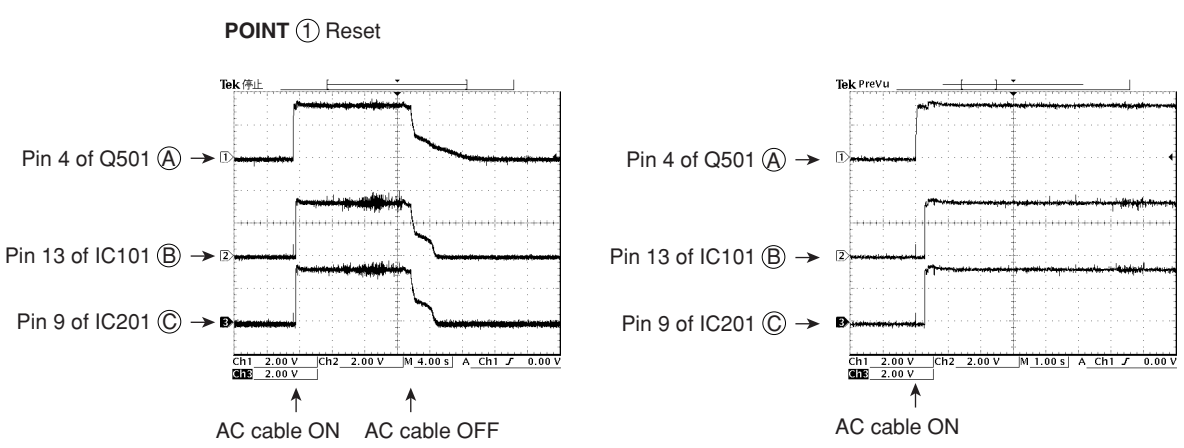
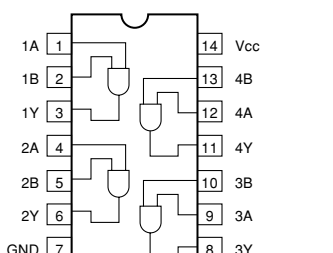

NOTICE [mode1]
(J)..... JAPAN
(U)..... U.S.A
(C)..... CANADA
(R)..... GENERAL
(T)..... CHINA
(K)..... KOREA
(A)..... AUSTRALIA
(B)..... BRITISH
(G)..... EUROPE
(L)..... SINGAPORE
(E)..... SOUTH EUROPE
(V)..... TAIWAN

* All voltages are measured with a 10MΩ/V DC electronic voltmeter.
* Components having special characteristics are marked with a triangle and must be replaced with parts having specifications equal to those originally installed.
* Schematic diagram is subject to change without notice.
● 電圧は、内部抵抗10MΩの電圧計で測定したものです。
● 三角形のある部品は、安全性能確保部品を示しています。部品の交換が必要な場合、パーツリストに記載されている部品を使用してください。
● 本回路図は標準回路図です。改良のため予告なく変更することがございます。

OPERATION 2/2

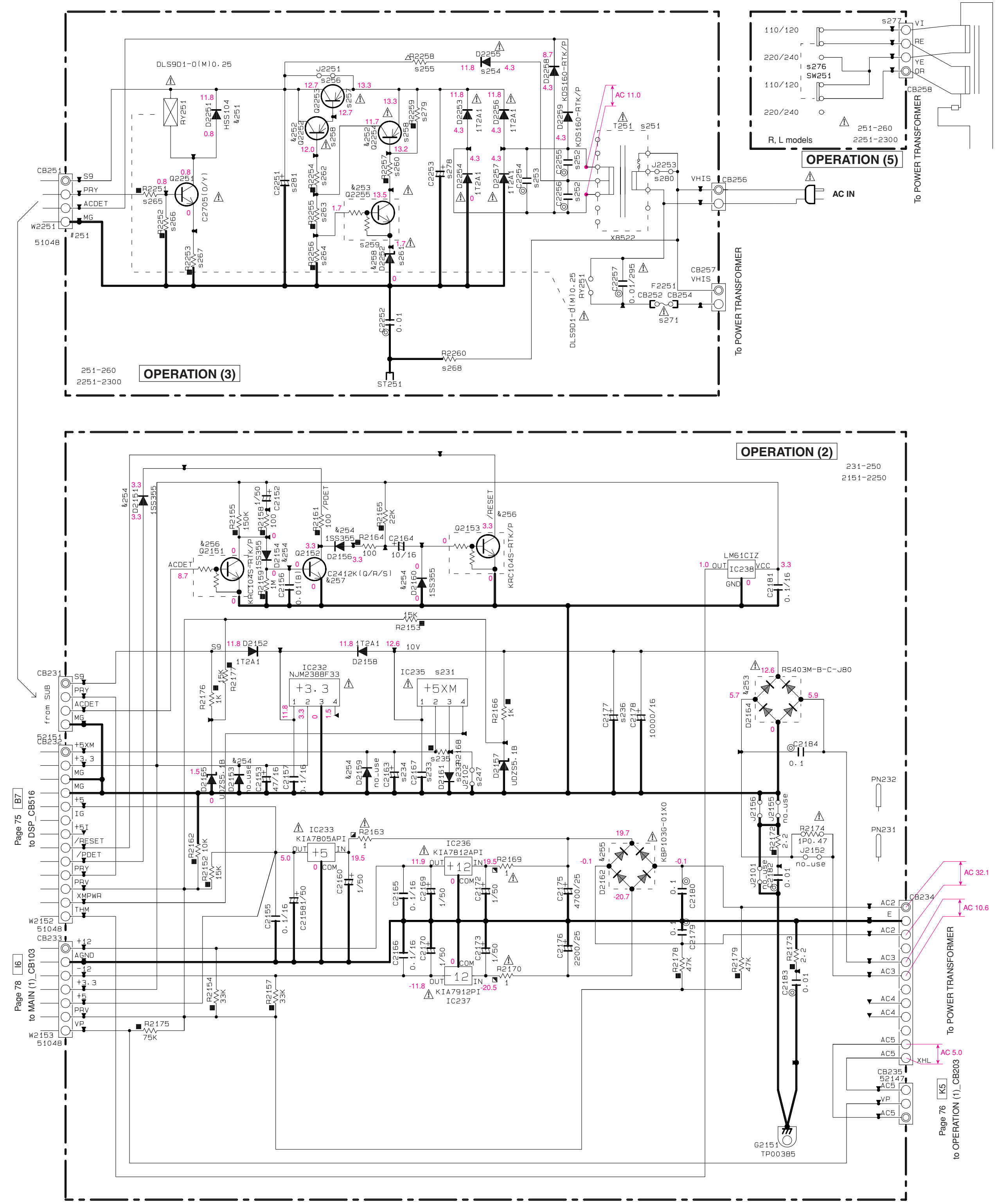

Destination Part List

sXX	LOC	J	UC	R	TKABGE	L
s231	IC235	X	X6143A0 NJM2388F05	X	X	X
s232	D2161	X	V237660 RB50V-40	X	X	X
s233	C2167	X	U519510 0.1/16	X	X	X
s234	C2163	X	UR93747 47/16	X	X	X
s235	R2168	X	RD35610 1K	X	X	X
s236	C2177	X	UR73A10 10000/16	X	X	X
s247	J2102	VN50000	X	VN50000	VN50000	VN50000
s251	T251	X8520A0 X8520	X8521A0 X8521	X8522A0 X8522	X8523A0 X8523	X8522A0 X8522
s252	C2256	X	X	WJ60500 0.01	X	WJ60500 0.01
s253	C2254	WJ60500 0.01	WJ60500 0.01	X	WJ60500 0.01	X
s254	D2255	X	X	V599780 1T2A1	X	V599780 1T2A1
s255	R2258	X	X	VC75790 2P47	X	VC75790 2P47
s256	J2251	VN50000	VN50000	X	VN50000	X
s257	Q2253	X	X	VPB7260 A17081(S/T1)	X	VPB7260 A17081(S/T1)
s258	Q2254 Q2252	X	X	IA10151 A10151(Y)	X	IA10151 A10151(Y)
s259	Q2255	X	X	WC52920 KRC102M-A1/P	X	WC52920 KRC102M-A1/P
s260	R2257	X	X	RD35747 47K	X	RD35747 47K
s261	D2252	X	X	VG43700 MTZJ4.7A	X	VG43700 MTZJ4.7A
s262	R2254	X	X	RD35610 1K	X	RD35610 1K
s263	R2255	X	X	RD35733 33K	X	RD35733 33K
s264	R2256	X	X	RD35656 5.6K	X	RD35656 5.6K
s265	R2251	RD35647 4.7K	RD35647 4.7K	RD35610 1K	RD35647 4.7K	RD35610 1K
s266	R2252	RD35810 100K	RD35810 100K	RD35547 470	RD35810 100K	RD35547 470
s267	R2253	RD35447 47	RD35447 47	RD35368 6.8	RD35447 47	RD35368 6.8
s268	R2260	X	V673000 1/2P2.2M	X	X	X
s271	F2251	WB22120 5.00A125V	WB22120 5.00A125V	WB22120 5.00A125V	VV07170 3.15A250V	WB22120 5.00A125V
s276	SW251	X	X	VZ07550 SL14-22AM5F	X	VZ07550 SL14-22AM5F
s277	CB258	X	X	V937790 B4P75-VH	X	V937790 B4P75-VH
s278	C2253	X	X	UR97110 10/100	X	UR97110 10/100
s279	R2259	X	X	RD35810 100K	X	RD35810 100K
s280	J2253	VN50000	VN50000	X	VN50000	X
s281	C2251	UR74922 2200/25	UR74922 2200/25	UR75922 2200/35	UR74922 2200/25	UR75922 2200/35

Interchangeable Parts at Manufacture-Stage

Mark	Reference Parts Number	Parts Name
k251	Q2251	HSS104 1SS133 1SS176
k252	Q2252-2254	2SA1015(Y) KT41266(Y)
k253	D2164	RS403M-B-C-J80 TS4B03G-07 X0
k254	D2151-2154-2156-2160	1SS355 MA111
k255	D2162	KBP103G RS103
k256	Q2151-2153	DTC144EKA KRC104S-RTK
k257	Q2152	2SC2412K(IQ/R/S) 2SD601ARL/AGL(IQ/R/S)
k258	D2252	MTZJ4.7A GDZJ4.7A

NOTICE (model)
 (J)..... JAPAN
 (U)..... U.S.A
 (C)..... CANADA
 (R)..... GENERAL
 (T)..... CHINA
 (K)..... KOREA
 (A)..... AUSTRALIA
 (B)..... BRITISH
 (G)..... EUROPE
 (L)..... SINGAPORE
 (E)..... SOUTH EUROPE
 (V)..... TAIWAN

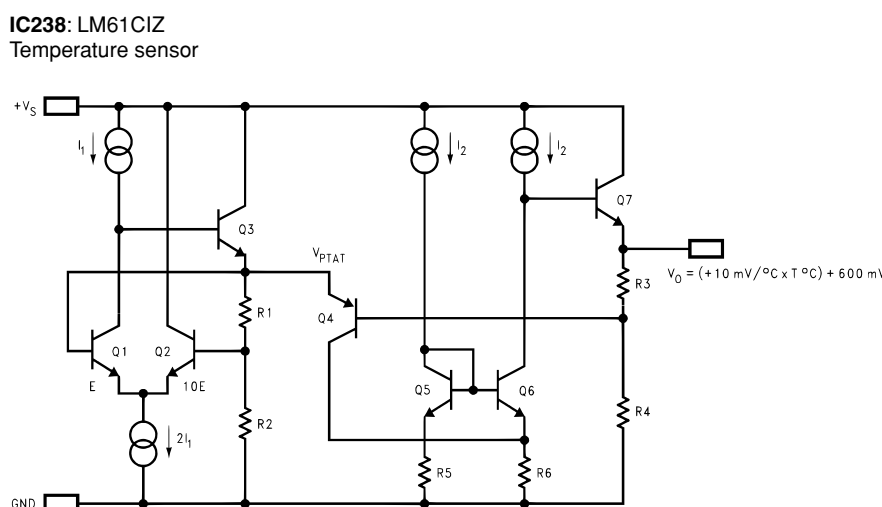
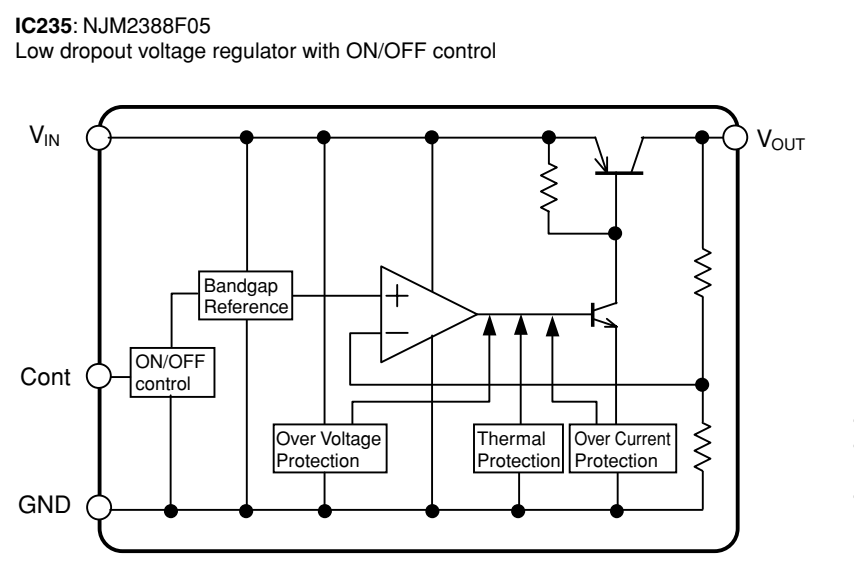
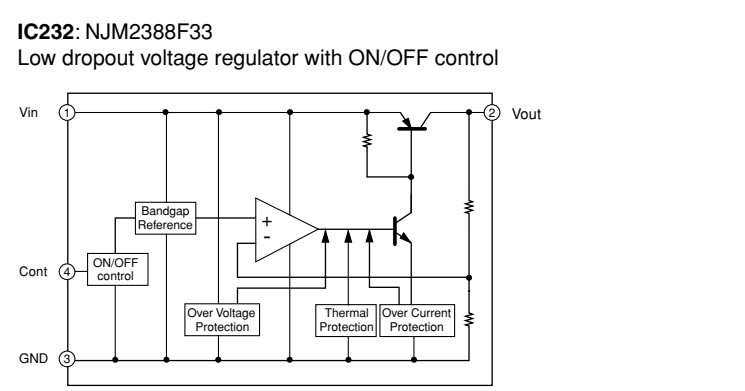
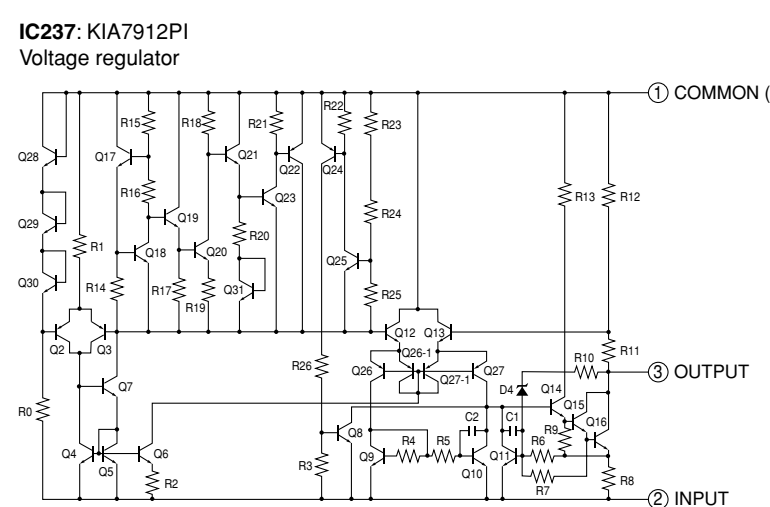
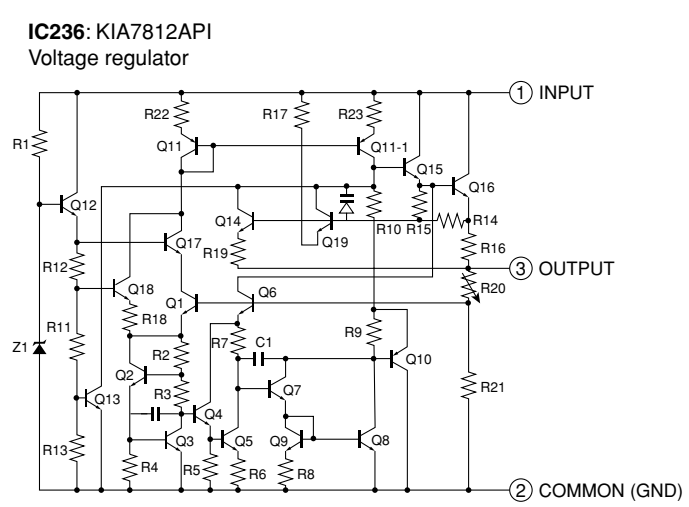
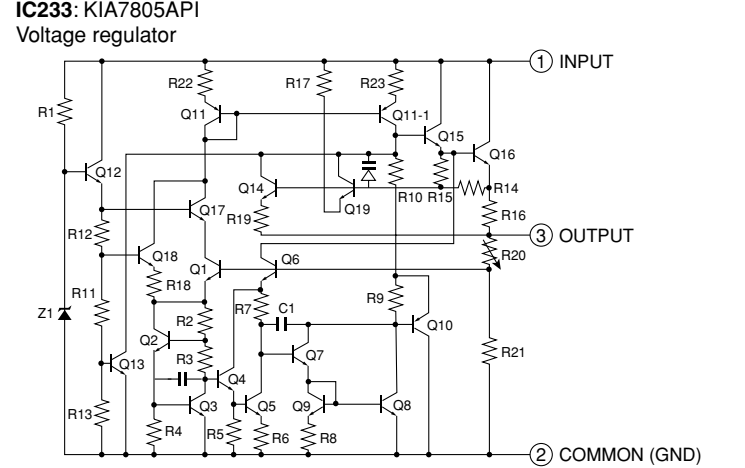

RESISTOR

REMARKS	PARTS NAME
NO MARK	CARBON FILM RESISTOR (P=5)
□	CARBON FILM RESISTOR (P=10)
△	METAL OXIDE FILM RESISTOR
▲	METAL FILM RESISTOR
⊠	METAL PLATE RESISTOR
⊞	FIRE PROOF CARBON FILM RESISTOR
□	CEMENT MOLDED RESISTOR
⊙	SEMI VARIABLE RESISTOR
■	CHIP RESISTOR

CAPACITOR

REMARKS	PARTS NAME
NO MARK	ELECTROLYTIC CAPACITOR
⊗	TANTALUM CAPACITOR
NO MARK	CERAMIC CAPACITOR
●	CERAMIC TUBULAR CAPACITOR
○	POLYESTER FILM CAPACITOR
○	POLYSTYRENE FILM CAPACITOR
⊖	MICA CAPACITOR
⊕	POLYPROPYLENE FILM CAPACITOR
⊙	SEMICONDUCTIVE CERAMIC CAPACITOR

* All voltages are measured with a 10MΩ/V DC electronic voltmeter.
 * Components having special characteristics are marked △ and must be replaced with parts having specifications equal to those originally installed.
 * Schematic diagram is subject to change without notice.
 ● 電圧は、内部抵抗10MΩの電圧計で測定したものです。
 ● △印のある部品は、安全性確保部品を示しています。部品の交換が必要な場合、パーツリストに記載されている部品を使用してください。
 ● 本回路図は標準回路図です。改良のため予告なく変更することがございます。

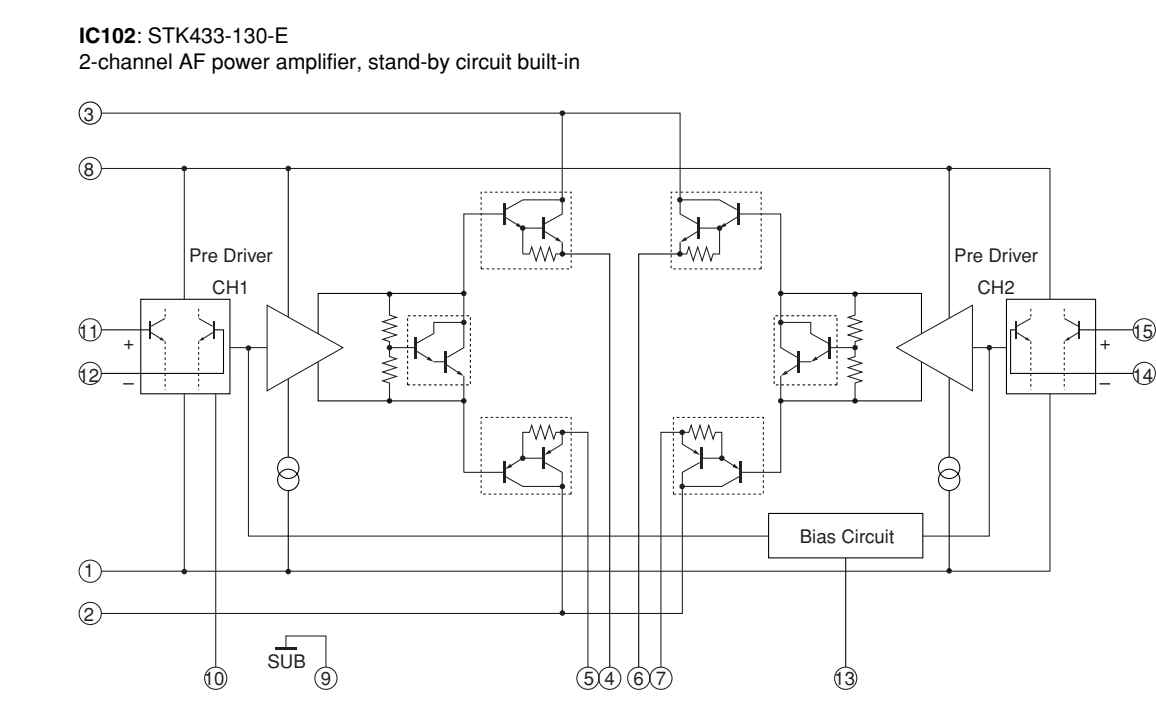
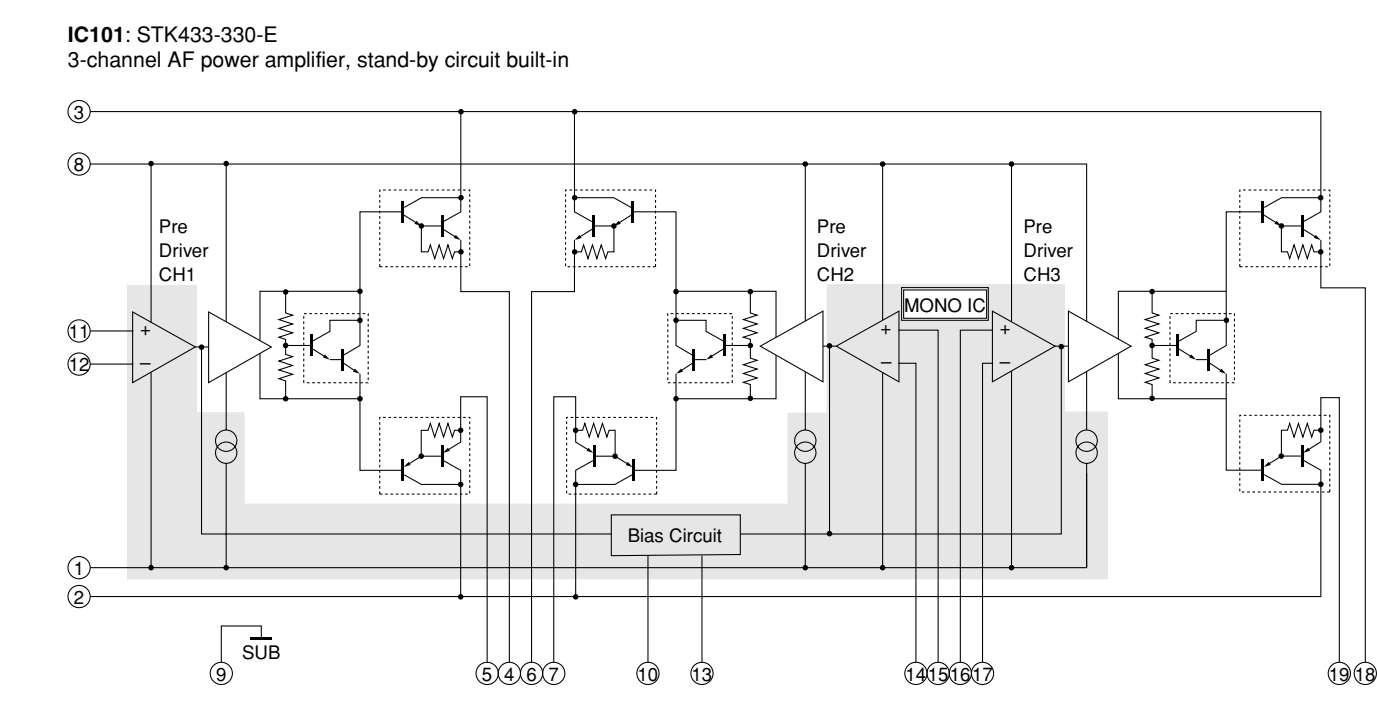
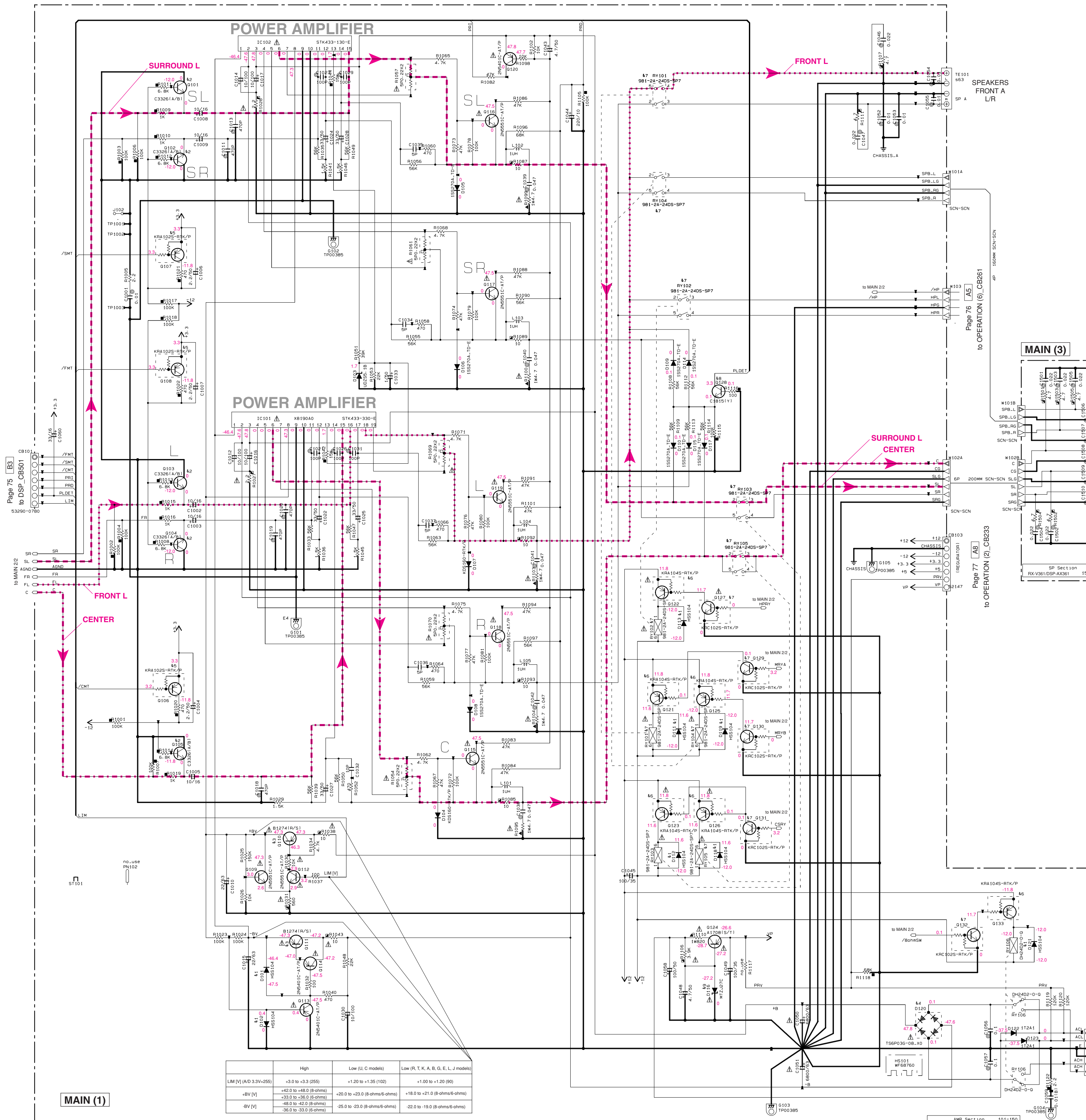

CAPACITOR

REMARKS	PARTS NAME
NO MARK	ELECTROLYTIC CAPACITOR
⊗	TANTALUM CAPACITOR
NO MARK	CERAMIC CAPACITOR
⊙	CERAMIC TUBULAR CAPACITOR
⊖	POLYESTER FILM CAPACITOR
⊕	POLYSTYRENE FILM CAPACITOR
⓪	MICA CAPACITOR
Ⓛ	POLYPROPYLENE FILM CAPACITOR
Ⓜ	SEMICONDUCTIVE CERAMIC CAPACITOR
Ⓢ	POLYPHENYLENE SULFIDE FILM CAPACITOR

RESISTOR

REMARKS	PARTS NAME
NO MARK	CARBON FILM RESISTOR (P=5)
□	CARBON FILM RESISTOR (P=10)
△	METAL OXIDE FILM RESISTOR
⊖	METAL FILM RESISTOR
⊕	METAL PLATE RESISTOR
⊗	FIRE PROOF CARBON FILM RESISTOR
Ⓜ	CEMENT MOLDED RESISTOR
Ⓢ	SEMI-VARIABLE RESISTOR
■	CHIP RESISTOR

NOTICE (model)

(J)..... JAPAN
(U)..... U.S.A
(C)..... CANADA
(R)..... GENERAL
(T)..... CHINA
(K)..... KOREA
(A)..... AUSTRALIA
(B)..... BRITISH
(G)..... EUROPE
(L)..... SINGAPORE
(E)..... SOUTH EUROPE
(V)..... TAIWAN

Interchangeable Parts at Manufacture-Stage

Mark	Reference Parts Number	Parts Name
41	D101-102-111-113	HSS104
	15S133	15S133
	11B-119-121	15S176
42	D101-105	25C3361A/B1
	25C3361B1	25C9938A1A/B1
	25D19381F1S/T	25D1938
43	D110-111	25B12741R/S1
	25B15601E/P1	25B1560
	KT41646-Y/V/P	KT41646
44	D120	T58P035-08-X0
	R5603M-B-C-J80	
45	D106-108	KRA1045-RTK/P
	DT114E4A	
46	D121-123-125-126-133	KRA1045-RTK/P
	DT114E4A	
47	D127-129-132	KRC1025-RTK/P
	DT114E4A	
48	D128	25C18151Y1
	KTC1398 Y-A1	
49	D116	MTZ27C
	GDZ27C	

* All voltages are measured with a 10MΩ/V DC electronic voltmeter.
* Components having special characteristics are marked !, and must be replaced with parts having specifications equal to those originally installed.
* Schematic diagram is subject to change without notice.

●電圧は、内部抵抗10MΩの電圧計で測定したものです。
●!印のある部品は、安全性確保部品を示しています。部品の交換が必要な場合、パーツリストに記載されている部品を使用してください。
●本回路図は標準回路図です。改良のため予告なく変更することがございます。

	High	Low (I, C models)	Low (R, T, K, A, B, G, E, L, J models)
LM [V] (A/D 3.3V-25V)	+3.0 to +3.3 (25V)	+1.20 to +1.35 (10Z)	+1.00 to +1.20 (9Z)
+8V [V]	+42.0 to +48.0 (8-ohms)	+20.0 to +23.0 (8-ohms/6-ohms)	+18.0 to +21.0 (8-ohms/6-ohms)
+5V [V]	+33.0 to +36.0 (8-ohms)	+8.0 to +12.0 (8-ohms/6-ohms)	+8.0 to +12.0 (8-ohms/6-ohms)
-8V [V]	-36.0 to -33.0 (8-ohms)	-25.0 to -23.0 (8-ohms/6-ohms)	-22.0 to -19.0 (8-ohms/6-ohms)

MAIN (1)

MAIN 2/2

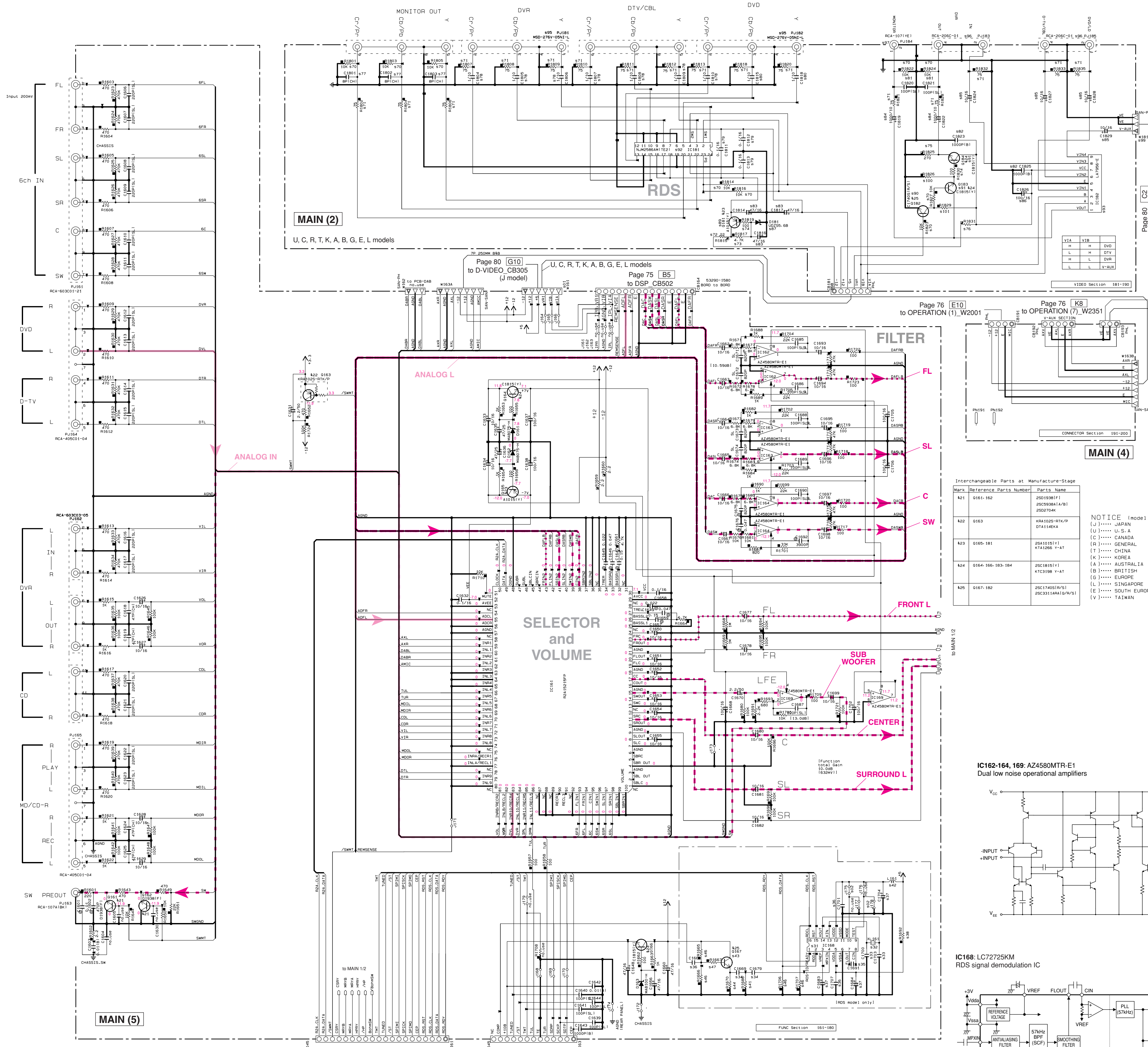

LOC	REF	PARTS	QTY	LOC	REF	PARTS	QTY
51	X1B1	MF40514	1	52	X1B2	MF40514	1
53	IC168	IC168	1	54	IC169	IC169	1
55	IC170	IC170	1	56	IC171	IC171	1
57	IC172	IC172	1	58	IC173	IC173	1
59	IC174	IC174	1	60	IC175	IC175	1
61	IC176	IC176	1	62	IC177	IC177	1
63	IC178	IC178	1	64	IC179	IC179	1
65	IC180	IC180	1	66	IC181	IC181	1
67	IC182	IC182	1	68	IC183	IC183	1
69	IC184	IC184	1	70	IC185	IC185	1
71	IC186	IC186	1	72	IC187	IC187	1
73	IC188	IC188	1	74	IC189	IC189	1
75	IC190	IC190	1	76	IC191	IC191	1
77	IC192	IC192	1	78	IC193	IC193	1
79	IC194	IC194	1	80	IC195	IC195	1
81	IC196	IC196	1	82	IC197	IC197	1
83	IC198	IC198	1	84	IC199	IC199	1
85	IC200	IC200	1	86	IC201	IC201	1
87	IC202	IC202	1	88	IC203	IC203	1
89	IC204	IC204	1	90	IC205	IC205	1
91	IC206	IC206	1	92	IC207	IC207	1
93	IC208	IC208	1	94	IC209	IC209	1
95	IC210	IC210	1	96	IC211	IC211	1
97	IC212	IC212	1	98	IC213	IC213	1
99	IC214	IC214	1	100	IC215	IC215	1
101	IC216	IC216	1	102	IC217	IC217	1
103	IC218	IC218	1	104	IC219	IC219	1
105	IC220	IC220	1	106	IC221	IC221	1
107	IC222	IC222	1	108	IC223	IC223	1
109	IC224	IC224	1	110	IC225	IC225	1
111	IC226	IC226	1	112	IC227	IC227	1
113	IC228	IC228	1	114	IC229	IC229	1
115	IC230	IC230	1	116	IC231	IC231	1
117	IC232	IC232	1	118	IC233	IC233	1
119	IC234	IC234	1	120	IC235	IC235	1
121	IC236	IC236	1	122	IC237	IC237	1
123	IC238	IC238	1	124	IC239	IC239	1
125	IC240	IC240	1	126	IC241	IC241	1
127	IC242	IC242	1	128	IC243	IC243	1
129	IC244	IC244	1	130	IC245	IC245	1
131	IC246	IC246	1	132	IC247	IC247	1
133	IC248	IC248	1	134	IC249	IC249	1
135	IC250	IC250	1	136	IC251	IC251	1
137	IC252	IC252	1	138	IC253	IC253	1
139	IC254	IC254	1	140	IC255	IC255	1
141	IC256	IC256	1	142	IC257	IC257	1
143	IC258	IC258	1	144	IC259	IC259	1
145	IC260	IC260	1	146	IC261	IC261	1
147	IC262	IC262	1	148	IC263	IC263	1
149	IC264	IC264	1	150	IC265	IC265	1
151	IC266	IC266	1	152	IC267	IC267	1
153	IC268	IC268	1	154	IC269	IC269	1
155	IC270	IC270	1	156	IC271	IC271	1
157	IC272	IC272	1	158	IC273	IC273	1
159	IC274	IC274	1	160	IC275	IC275	1
161	IC276	IC276	1	162	IC277	IC277	1
163	IC278	IC278	1	164	IC279	IC279	1
165	IC280	IC280	1	166	IC281	IC281	1
167	IC282	IC282	1	168	IC283	IC283	1
169	IC284	IC284	1	170	IC285	IC285	1
171	IC286	IC286	1	172	IC287	IC287	1
173	IC288	IC288	1	174	IC289	IC289	1
175	IC290	IC290	1	176	IC291	IC291	1
177	IC292	IC292	1	178	IC293	IC293	1
179	IC294	IC294	1	180	IC295	IC295	1
181	IC296	IC296	1	182	IC297	IC297	1
183	IC298	IC298	1	184	IC299	IC299	1
185	IC300	IC300	1	186	IC301	IC301	1
187	IC302	IC302	1	188	IC303	IC303	1
189	IC304	IC304	1	190	IC305	IC305	1
191	IC306	IC306	1	192	IC307	IC307	1
193	IC308	IC308	1	194	IC309	IC309	1
195	IC310	IC310	1	196	IC311	IC311	1
197	IC312	IC312	1	198	IC313	IC313	1
199	IC314	IC314	1	200	IC315	IC315	1
201	IC316	IC316	1	202	IC317	IC317	1
203	IC318	IC318	1	204	IC319	IC319	1
205	IC320	IC320	1	206	IC321	IC321	1
207	IC322	IC322	1	208	IC323	IC323	1
209	IC324	IC324	1	210	IC325	IC325	1
211	IC326	IC326	1	212	IC327	IC327	1
213	IC328	IC328	1	214	IC329	IC329	1
215	IC330	IC330	1	216	IC331	IC331	1
217	IC332	IC332	1	218	IC333	IC333	1
219	IC334	IC334	1	220	IC335	IC335	1
221	IC336	IC336	1	222	IC337	IC337	1
223	IC338	IC338	1	224	IC339	IC339	1
225	IC340	IC340	1	226	IC341	IC341	1
227	IC342	IC342	1	228	IC343	IC343	1
229	IC344	IC344	1	230	IC345	IC345	1
231	IC346	IC346	1	232	IC347	IC347	1
233	IC348	IC348	1	234	IC349	IC349	1
235	IC350	IC350	1	236	IC351	IC351	1
237	IC352	IC352	1	238	IC353	IC353	1
239	IC354	IC354	1	240	IC355	IC355	1
241	IC356	IC356	1	242	IC357	IC357	1
243	IC358	IC358	1	244	IC359	IC359	1
245	IC360	IC360	1	246	IC361	IC361	1
247	IC362	IC362	1	248	IC363	IC363	1
249	IC364	IC364	1	250	IC365	IC365	1
251	IC366	IC366	1	252	IC367	IC367	1
253	IC368	IC368	1	254	IC369	IC369	1
255	IC370	IC370	1	256	IC371	IC371	1
257	IC372	IC372	1	258	IC373	IC373	1
259	IC374	IC374	1	260	IC375	IC375	1
261	IC376	IC376	1	262	IC377	IC377	1
263	IC378	IC378	1	264	IC379	IC379	1
265	IC380	IC380	1	266	IC381	IC381	1
267	IC382	IC382	1	268	IC383	IC383	1
269	IC384	IC384	1	270	IC385	IC385	1
271	IC386	IC386	1	272	IC387	IC387	1
273	IC388	IC388	1	274	IC389	IC389	1
275	IC390	IC390	1	276	IC391	IC391	1
277	IC392	IC392	1	278	IC393	IC393	1
279	IC394	IC394	1	280	IC395	IC395	1
281	IC396	IC396	1	282	IC397	IC397	1
283	IC398	IC398	1	284	IC399	IC399	1
285	IC400	IC400	1	286	IC401	IC401	1
287	IC402	IC402	1	288	IC403	IC403	1
289	IC404	IC404	1	290	IC405	IC405	1
291	IC406	IC406	1	292	IC407	IC407	1
293	IC408	IC408	1	294	IC409	IC409	1
295	IC410	IC410	1	296	IC411	IC411	1
297	IC412	IC412	1	298	IC413	IC413	1
299	IC414	IC414	1	300	IC415	IC415	1
301	IC416	IC416	1	302	IC417	IC417	1
303	IC418	IC418	1	304	IC419	IC419	1
305	IC420	IC420	1	306	IC421	IC421	1
307	IC422	IC422	1	308	IC423	IC423	1
309	IC424	IC424	1	310	IC425	IC425	1
311	IC426	IC426	1	312	IC427	IC427	1
313	IC428	IC428	1	314	IC429	IC429	1
315	IC430	IC430	1	316	IC431	IC431	1
317	IC432	IC432	1	318	IC433	IC433	1
319	IC434	IC434	1	320	IC435	IC435	1
321	IC436	IC436	1	322	IC437	IC437	1
323	IC438	IC438	1	324	IC439	IC439	1
325	IC440	IC440	1	326	IC441	IC441	1
327	IC442	IC442	1	328	IC443	IC443	1
329	IC444	IC444	1	330	IC445	IC445	1
331	IC446	IC446	1	332	IC447	IC447	1
333	IC448	IC448	1	334	IC449	IC449	1
335	IC450	IC450	1	336	IC451	IC451	1
337	IC452	IC452	1	338	IC453	IC453	1
339	IC454	IC454	1	340	IC455	IC455	1
341	IC456	IC456	1	342	IC457	IC457	1
343	IC458	IC458	1	344	IC459	IC459	1
345	IC460	IC460	1	346	IC461	IC461	1
347	IC462	IC462	1	348	IC463	IC463	1
349	IC464	IC464	1	350	IC465	IC465	1
351	IC466	IC466	1	352	IC467	IC467	1
353	IC468	IC468					

D-VIDEO (J model)

Page 79 J4
to MAIN (4)_CB193

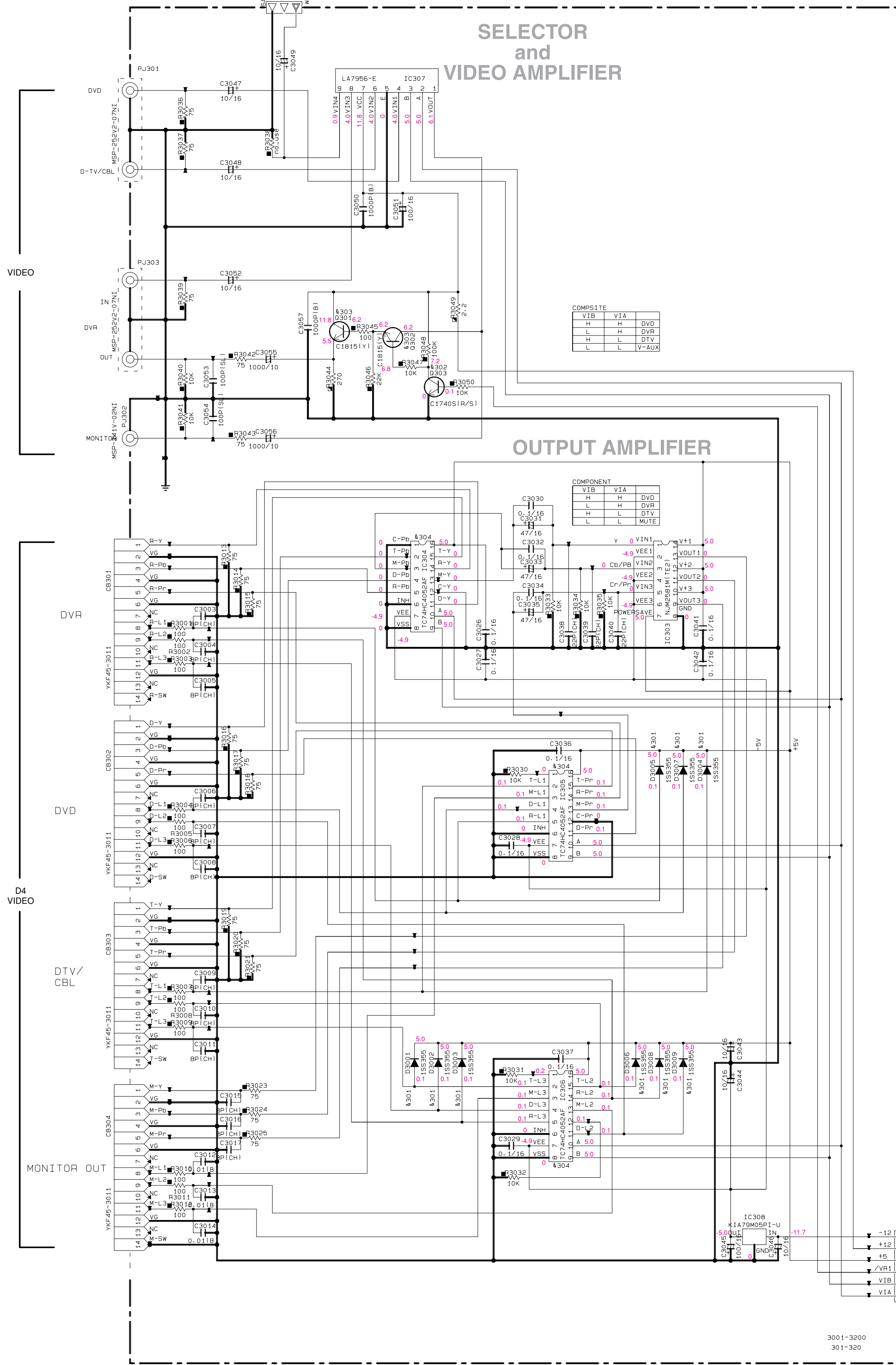

CAPACITOR

REMARKS	PARTS NAME
NO MARK	ELECTROLYTIC CAPACITOR
⊗	TANTALUM CAPACITOR
NO MARK	CERAMIC CAPACITOR
●	CERAMIC TUBULAR CAPACITOR
○	POLYESTER FILM CAPACITOR
○	POLYSTYRENE FILM CAPACITOR
⊖	MICA CAPACITOR
⊕	POLYPROPYLENE FILM CAPACITOR
⊙	SEMICONDUCTIVE CERAMIC CAPACITOR

RESISTOR

REMARKS	PARTS NAME
NO MARK	CARBON FILM RESISTOR (P=5)
□	CARBON FILM RESISTOR (P=10)
△	METAL OXIDE FILM RESISTOR
△	METAL FILM RESISTOR
⊠	METAL PLATE RESISTOR
⊠	FIRE PROOF CARBON FILM RESISTOR
□	CEMENT MOLDED RESISTOR
⊖	SEMI VARIABLE RESISTOR
⊠	CHIP RESISTOR

NOTICE (mode1)
(J)..... JAPAN
(U)..... U.S.A
(C)..... CANADA
(R)..... GENERAL
(T)..... CHINA
(K)..... KOREA
(A)..... AUSTRALIA
(B)..... BRITISH
(G)..... EUROPE
(L)..... SINGAPORE
(E)..... SOUTH EUROPE
(V)..... TAIWAN

Interchangeable Parts at Manufacture-Stage

Mark	Reference Parts Number	Parts Name
Ⓚ301	D3001-3009	1S5355 MA111
Ⓚ302	0303	25C1740S1R/S1 25C3311A1G/R/S1
Ⓚ303	D301-302	25C1815V1 KTC31981V1
Ⓚ304	IC304-306	TC74HC4052AF MM74HC4052SJK_NL

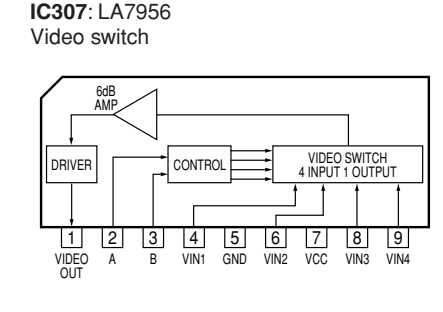
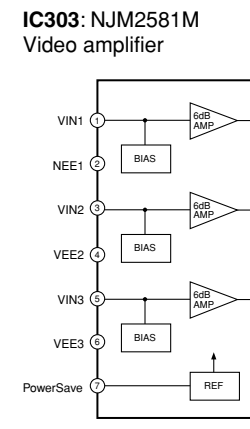
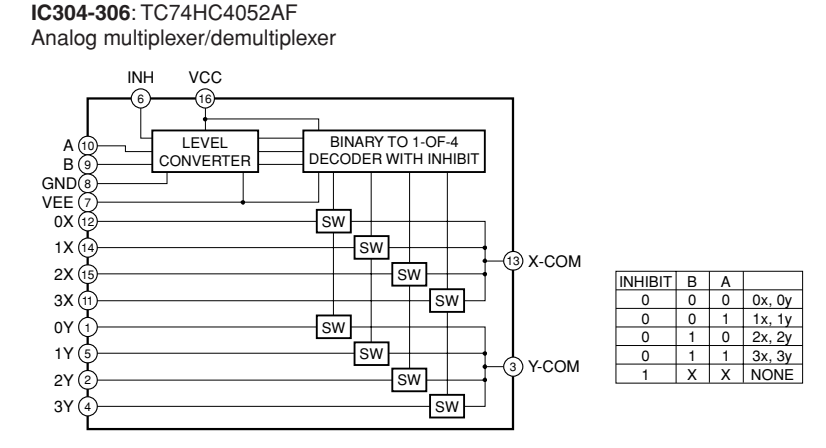
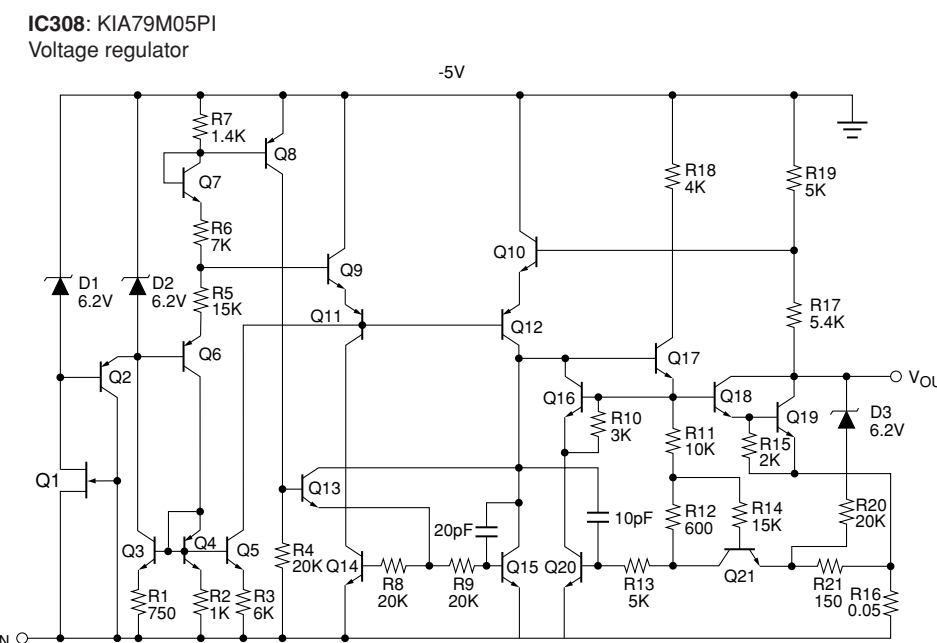

Page 79 E4
to MAIN (5)_W161

★ All voltages are measured with a 10MΩ/2V DC electronic voltmeter.
★ Components having special characteristics are marked with a triangle and must be replaced with parts having specifications equal to those originally installed.
★ Schematic diagram is subject to change without notice.
● 電圧は、内部抵抗10MΩの電圧計で測定したものです。
● 印のある部品は、安全性確保部品を示しています。部品の交換が必要な場合、パーツリストに記載されている部品を使用してください。
● 本回路図は標準回路図です。改良のため予告なく変更することがございます。

■ REPLACEMENT PARTS LIST

• ELECTRICAL COMPONENT PARTS

WARNING

- Components having special characteristics are marked \triangle and must be replaced with parts having specifications equal to those originally installed.
- The chip resistor is not supplied as a replacement part.
 - * When a chip resistor is necessary, use the following part.
AAX60720: CHIP RESISTOR SAMPLE BOOK
- \triangle 印のある部分は、安全確保部品を示しています。部品の交換が必要な場合、パーツリストに記載されている部品を使用してください。
- 部品価格ランクは、予告なく変更することがあります。
- チップ抵抗はサービス部品として供給しません。
 - ※ チップ抵抗が必要な場合は、下記の部品をご利用ください。
AAX60720: CHIP RESISTOR SAMPLE BOOK

ABBREVIATIONS IN THIS LIST ARE AS FOLLOWS:

C.A.EL.CHP	: CHIP ALUMI.ELECTROLYTIC CAP	L.EMIT	: LIGHT EMITTING MODULE
C.CE	: CERAMIC CAP	LED.DSPLY	: LED DISPLAY
C.CE.ARRAY	: CERAMIC CAP ARRAY	LED.INFRD	: LED,INFRARED
C.CE.CHP	: CHIP CERAMIC CAP	MODUL.RF	: MODULATOR,RF
C.CE.ML	: MULTILAYER CERAMIC CAP	PHOT.CPL	: PHOTO COUPLER
C.CE.M.CHP	: CHIP MULTILAYER CERAMIC CAP	PHOT.INTR	: PHOTO INTERRUPTER
C.CE.SAFTY	: RECOGNIZED CERAMIC CAP	PHOT.RFLCT	: PHOTO REFLECTOR
C.CE.TUBLR	: CERAMIC TUBULAR CAP	PIN.TEST	: PIN,TEST POINT
C.CE.SMI	: SEMI CONDUCTIVE CERAMIC CAP	PLST.RIVET	: PLASTIC RIVET
C.EL	: ELECTROLYTIC CAP	R.ARRAY	: RESISTOR ARRAY
C.MICA	: MICA CAP	R.CAR.	: CARBON RESISTOR
C.ML.FLM	: MULTILAYER FILM CAP	R.CAR.CHP	: CHIP RESISTOR
C.MP	: METALLIZED PAPER CAP	R.CAR.FP	: FLAME PROOF CARBON RESISTOR
C.MYLAR	: MYLAR FILM CAP	R.FUS	: FUSABLE RESISTOR
C.MYLAR.ML	: MULTILAYER MYLAR FILM CAP	R.MTL.CHP	: CHIP METAL FILM RESISTOR
C.PAPER	: PAPER CAPACITOR	R.MTL.FLM	: METAL FILM RESISTOR
C.PLS	: POLYSTYRENE FILM CAP	R.MTL.OXD	: METAL OXIDE FILM RESISTOR
C.POL	: POLYESTER FILM CAP	R.MTL.PLAT	: METAL PLATE RESISTOR
C.POLY	: POLYETHYLENE FILM CAP	RSNR.CE	: CERAMIC RESONATOR
C.PP	: POLYPROPYLENE FILM CAP	RSNR.CRYS	: CRYSTAL RESONATOR
C.TNTL	: TANTALUM CAP	R.TW.CEM	: TWIN CEMENT FIXED RESISTOR
C.TNTL.CHP	: CHIP TANTALUM CAP	R.CEMENT	: CEMENT RESISTOR
C.TRIM	: TRIMMER CAP	SCR.BND.HD	: BIND HEAD B-TIGHT SCREW
CN	: CONNECTOR	SCR.BW.HD	: BW HEAD TAPPING SCREW
CN.BS.PIN	: CONNECTOR,BASE PIN	SCR.CUP	: CUP TIGHT SCREW
CN.CANNON	: CONNECTOR,CANNON	SCR.TERM	: SCREW TERMINAL
CN.DIN	: CONNECTOR,DIN	SCR.TR	: SCREW,TRANSISTOR
CN.FLAT	: CONNECTOR,FLAT CABLE	SUPRT.PCB	: SUPPORT,P.C.B.
CN.POST	: CONNECTOR,BASE POST	SURG.PRTCT	: SURGE PROTECTOR
COIL.MX.AM	: COIL,AM MIX	SW.TACT	: TACT SWITCH
COIL.AT.FM	: COIL,FM ANTENNA	SW.LEAF	: LEAF SWITCH
COIL.DT.FM	: COIL,FM DETECT	SW.LEVER	: LEVER SWITCH
COIL.MX.FM	: COIL,FM MIX	SW.MICRO	: MICRO SWITCH
COIL.OUTPT	: OUTPUT COIL	SW.PUSH	: PUSH SWITCH
DIOD.ARRAY	: DIODE ARRAY	SW.RT.ENC	: ROTARY ENCODER
DIODE.BRG	: DIODE BRIDGE	SW.RT.MTR	: ROTARY SWITCH WITH MOTOR
DIODE.CHP	: CHIP DIODE	SW.RT	: ROTARY SWITCH
DIODE.VAR	: VARACTOR DIODE	SW.SLIDE	: SLIDE SWITCH
DIOD.Z.CHP	: CHIP ZENER DIODE	TERM.SP	: SPEAKER TERMINAL
DIODE.ZENR	: ZENER DIODE	TERM.WRAP	: WRAPPING TERMINAL
DSCR.CE	: CERAMIC DISCRIMINATOR	THRMST.CHP	: CHIP THERMISTOR
FER.BEAD	: FERRITE BEADS	TR.CHP	: CHIP TRANSISTOR
FER.CORE	: FERRITE CORE	TR.DGT	: DIGITAL TRANSISTOR
FET.CHP	: CHIP FET	TR.DGT.CHP	: CHIP DIGITAL TRANSISTOR
FL.DSPLY	: FLUORESCENT DISPLAY	TRANS	: TRANSFORMER
FLTR.CE	: CERAMIC FILTER	TRANS.PULS	: PULSE TRANSFORMER
FLTR.COMB	: COMB FILTER MODULE	TRANS.PWR	: POWER TRANSFORMER ASS'Y
FLTR.LC.RF	: LC FILTER,EMI	TUNER.AM	: TUNER PACK,AM
GND.MTL	: GROUND PLATE	TUNER.FM	: TUNER PACK,FM
GND.TERM	: GROUND TERMINAL	TUNER.PK	: FRONT-ENDTUNER PACK
HOLDER.FUS	: FUSE HOLDER	VR	: ROTARY POTENTIOMETER
IC.PRTCT	: IC PROTECTOR	VR.MTR	: POTENTIOMETER WITH MOTOR
JUMPER.CN	: JUMPER CONNECTOR	VR.SW	: POTENTIOMETER WITH ROTARY SW
JUMPER.TST	: JUMPER,TEST POINT	VR.SLIDE	: SLIDE POTENTIOMETER
L.DTCT	: LIGHT DETECTING MODULE	VR.TRIM	: TRIMMER POTENTIOMETER

P.C.B. DSP

Ref No.	Part No.	Description	Remarks	Markets	部 品 名	ランク	
	WJ641900	P. C. B.	DSP		J	P C B D S P	
	WJ642000	P. C. B.	DSP		UC	P C B D S P	
	WJ642100	P. C. B.	DSP		R	P C B D S P	
	WJ642200	P. C. B.	DSP		T	P C B D S P	
	WJ642300	P. C. B.	DSP		KA	P C B D S P	
	WJ642400	P. C. B.	DSP		BGE	P C B D S P	
	WJ642500	P. C. B.	DSP		L	P C B D S P	
	CB302	WJ458700	CN. XM	4P	UC	X Mコネクタ	
	CB408	VF982300	CN. BS. PIN	17P		F F Cコネクタ	01
	CB501	VQ961000	CN. BS. PIN	7P		ハウジング	02
	CB502	VQ961800	CN. BS. PIN	15P		ハウジング	01
	CB512	VQ047500	CN. BS. PIN	20P		F F Cコネクタ	01
	CB516	VK025700	CN. BS. PIN	13P		ワイヤートラップ	01
	C101	UR838220	C. EL	220uF 16V		ケミコン	01
	C102	WH771300	C. EL	100uF 10V		ケミコン	01
	C103-104	US135100	C. CE. CHP	0.1uF 16V		チップセラコン	01
	C105	US061270	C. CE. CHP	27pF 50V B		チップセラコン	01
	C106	WH771300	C. EL	100uF 10V		ケミコン	01
	C107	US135100	C. CE. CHP	0.1uF 16V		チップセラコン	01
	C108-129	US063100	C. CE. CHP	1000pF 50V B		チップセラコン	01
	C130	US135100	C. CE. CHP	0.1uF 16V		チップセラコン	01
	C131	US061270	C. CE. CHP	27pF 50V B		チップセラコン	01
	C132	UR837100	C. EL	10uF 16V		ケミコン	01
	C133	US063100	C. CE. CHP	1000pF 50V B		チップセラコン	01
	C135	UB446100	C. CE. CHP	1uF 16V		チップセラコン	01
	C136-147	US063100	C. CE. CHP	1000pF 50V B		チップセラコン	01
	C148-154	UB446100	C. CE. CHP	1uF 16V		チップセラコン	01
	C201-206	US063100	C. CE. CHP	1000pF 50V B		チップセラコン	01
	C207-211	US135100	C. CE. CHP	0.1uF 16V		チップセラコン	01
	C212	US063100	C. CE. CHP	1000pF 50V B		チップセラコン	01
	C215-218	UB446100	C. CE. CHP	1uF 16V		チップセラコン	01
	C301-304	US135100	C. CE. CHP	0.1uF 16V		チップセラコン	01
	C305	UR837470	C. EL	47uF 16V		ケミコン	01
	C306	US135100	C. CE. CHP	0.1uF 16V		チップセラコン	01
	C307	US063100	C. CE. CHP	1000pF 50V B		チップセラコン	01
	C308	UR837100	C. EL	10uF 16V		ケミコン	01
	C309-310	US061270	C. CE. CHP	27pF 50V B		チップセラコン	01
	C311	UR866220	C. EL	2.2uF 50V		ケミコン	01
	C312	US135100	C. CE. CHP	0.1uF 16V		チップセラコン	01
	C313	US061220	C. CE. CHP	22pF 50V B		チップセラコン	01
	C314	UR847220	C. EL	22uF 25V		ケミコン	01
	C315-317	US135100	C. CE. CHP	0.1uF 16V		チップセラコン	01
	C321	US135100	C. CE. CHP	0.1uF 16V		チップセラコン	01
	C322-323	US135100	C. CE. CHP	0.1uF 16V	UC	チップセラコン	01
	C330-332	US135100	C. CE. CHP	0.1uF 16V	UC	チップセラコン	01
	C335-336	US061100	C. CE. CHP	10pF 50V B	UC	チップセラコン	01
	C337-340	US135100	C. CE. CHP	0.1uF 16V	UC	チップセラコン	01
	C341	UR837470	C. EL	47uF 16V	UC	ケミコン	01
	C342-346	US063100	C. CE. CHP	1000pF 50V B		チップセラコン	01
	C349-350	UR837100	C. EL	10uF 16V		ケミコン	01
	C351-352	US063100	C. CE. CHP	1000pF 50V B		チップセラコン	01
	C353	US135100	C. CE. CHP	0.1uF 16V	UC	チップセラコン	01
	C354	US063100	C. CE. CHP	1000pF 50V B		チップセラコン	01
	C401-402	US135100	C. CE. CHP	0.1uF 16V		チップセラコン	01
	C404	UR837470	C. EL	47uF 16V		ケミコン	01

* New Parts * 新規部品

P.C.B. DSP

Ref No.	Part No.	Description	Remarks	Markets	部 品 名	ランク
C405	US135100	C. CE. CHP	0.1uF 16V		チップセラコン	01
C406	UB446100	C. CE. CHP	1uF 16V		チップセラコン	01
C407-408	US062100	C. CE. CHP	100pF 50V B		チップセラコン	01
C409	US135100	C. CE. CHP	0.1uF 16V		チップセラコン	01
C410	US062100	C. CE. CHP	100pF 50V B		チップセラコン	01
C413-416	US063100	C. CE. CHP	1000pF 50V B		チップセラコン	01
C417	US062470	C. CE. CHP	470pF 50V B		チップセラコン	01
C418-423	US063100	C. CE. CHP	1000pF 50V B		チップセラコン	01
C424	US135100	C. CE. CHP	0.1uF 16V		チップセラコン	01
C425-428	US063100	C. CE. CHP	1000pF 50V B		チップセラコン	01
C429-435	US062100	C. CE. CHP	100pF 50V B		チップセラコン	01
C501	US062100	C. CE. CHP	100pF 50V B		チップセラコン	01
C502	UR838220	C. EL	220uF 16V		ケミコン	01
C503-504	US062100	C. CE. CHP	100pF 50V B		チップセラコン	01
C516	US035100	C. CE. CHP	0.1uF 16V B		チップセラコン	01
C517-518	US062100	C. CE. CHP	100pF 50V B		チップセラコン	01
C519	US135100	C. CE. CHP	0.1uF 16V		チップセラコン	01
C520	US035100	C. CE. CHP	0.1uF 16V B		チップセラコン	01
C521	US063100	C. CE. CHP	1000pF 50V B		チップセラコン	01
C522-523	US135100	C. CE. CHP	0.1uF 16V		チップセラコン	01
C524-525	US063100	C. CE. CHP	1000pF 50V B		チップセラコン	01
C527-528	US064100	C. CE. CHP	0.01uF 50V B		チップセラコン	01
C529	US062100	C. CE. CHP	100pF 50V B		チップセラコン	01
C530	US064100	C. CE. CHP	0.01uF 50V B		チップセラコン	01
C531-534	US062100	C. CE. CHP	100pF 50V B		チップセラコン	01
C536-549	US062100	C. CE. CHP	100pF 50V B		チップセラコン	01
C550	US064100	C. CE. CHP	0.01uF 50V B		チップセラコン	01
C623	US063100	C. CE. CHP	1000pF 50V B		チップセラコン	01
D101	VS597600	DIODE. CHP	RB160L-40 TE25		チップダイオード	01
D301-303	WE674800	DIODE	AVRL161A1R1NTB	UC	チップバリスタ	01
D401	VU171400	DIODE. ZENR	UDZS3.3BTE-17 3.3V	BGE	ツェナーダイオード	
D402	VU171400	DIODE. ZENR	UDZS3.3BTE-17 3.3V		ツェナーダイオード	
D403-404	VU171400	DIODE. ZENR	UDZS3.3BTE-17 3.3V		ツェナーダイオード	
D405	VT332900	DIODE	1SS355		ダイオード	01
D407	VT332900	DIODE	1SS355		ダイオード	01
D408	VU171400	DIODE. ZENR	UDZS3.3BTE-17 3.3V		ツェナーダイオード	
G101	WB438000	TERM. GND	M4 SD00433-21		アース端子	
* IC101	X7534A00	IC. CPU	ADSP-BF531 CPU		CPU IC	
* IC102	X8653A00	IC	BR25L320F-W EEPROM		メモリ IC	
* IC201	X8655C00	IC	S29AL008D70TFI020	boot only	メモリ IC	
IC202	XZ414C00	IC	W9864G6EH-7 SDRAM		メモリ IC 64M	07
IC203	X4201A00	IC	SN74AHC02PWR		ロジック IC	01
IC204-206	X4285A00	IC	SN74LV573APWR		ロジック IC	02
* IC301	X7919A00	IC	AK4588VQ		IC CODEC	
IC305	X3936A00	IC	SN74LVU04APWR		ロジック IC	
* IC306	X8192A00	IC	F2621E-01-TR	UC	IC	
IC307	X6123A00	IC	SN74LV157APWR	UC	ロジック IC	02
IC401	X6905A00	IC	ADC084S021CIMM		ADコンバーター	04
IC402-403	X5875A00	IC	SN74LV4051APWR		ロジック IC	01
IC404	X2709A00	IC	SN74AHCT245PWR		ロジック IC	02
IC501	X3824A00	IC	SN74AHCT08PWR		ロジック IC	01
IC505	X4463A00	IC	SN74LV08APWR		ロジック IC	01
* PJ301	V8795700	JACK. PIN	1P		ピンジャック	
Q101	WE736300	FET	RTQ040P02		FET	01
Q501	WE736300	FET	RTQ040P02		FET	01

* New Parts * 新規部品

P.C.B. DSP and P.C.B. OPERATION
--

Ref No.	Part No.	Description	Remarks	Markets	部 品 名	ランク	
* XL101	U301-302 WJ625100	CN. PHOTO. R	1P JSR1151-D			光ファイバー受信器	03
* XL301	VZ540700	RSNR. CRYST	25MHz SMD-49			水晶振動子	
* XL302	WJ625200	RSNR. CRYST	24.576MHz			水晶振動子	
	WH455300	RSNR. CRYST	45.1584MHz	UC		水晶振動子	
* * * * *	WJ643600 WJ643700 WJ643800 WJ643900 WJ644000		OPERATION OPERATION OPERATION OPERATION OPERATION	J UC R TKABGE L	P C B オペレーション P C B オペレーション P C B オペレーション P C B オペレーション P C B オペレーション		
	CB202	VF982300	CN. BS. PIN	17P		F F Cコネクタ	01
	CB231	VK026300	CN. BS. PIN	4P		ワイヤートラップ	01
	CB234	LB919120	CN. BS. PIN	12P		ベースツキポスト	02
	CB235	VK024700	CN. BS. PIN	3P		ワイヤートラップ	01
	CB252	WC050700	CL. IP. FUSE	EYF-52BCY		ヒューズクリップ	01
	CB254	WC050700	CL. IP. FUSE	EYF-52BCY		ヒューズクリップ	01
	CB256-257	VG879900	CN. BS. PIN	2P		ベースピン	01
* CB258	V9377900	CN. BS. PIN	4P	RL		ベース付ポスト	
	CB261	VB858300	CN. BS. PIN	4P		コネクタベースポスト	01
	C2001	US035100	C. CE. CHP	0.1uF 16V B		チップセラコン	01
	C2006	US135100	C. CE. CHP	0.1uF 16V		チップセラコン	01
	C2012	US065100	C. CE. CHP	0.1uF 50V B		チップセラコン	
	C2013-2014	US135100	C. CE. CHP	0.1uF 16V		チップセラコン	01
	C2015	UR868100	C. EL	100uF 50V		ケミコン	01
	C2016	UM388330	C. EL	330uF 6.3V		ケミコン	01
	C2017	US135100	C. CE. CHP	0.1uF 16V		チップセラコン	01
	C2018	US061680	C. CE. CHP	68pF 50V		チップセラコン	01
	C2019-2020	US062100	C. CE. CHP	100pF 50V B		チップセラコン	01
	C2021	US061100	C. CE. CHP	10pF 50V B		チップセラコン	01
	C2022-2024	US135100	C. CE. CHP	0.1uF 16V		チップセラコン	01
	C2025	US064100	C. CE. CHP	0.01uF 50V B		チップセラコン	01
	C2026	US135100	C. CE. CHP	0.1uF 16V		チップセラコン	01
	C2027	UM397100	C. EL	10uF 16V		ケミコン	01
	C2028	US135100	C. CE. CHP	0.1uF 16V		チップセラコン	01
	C2029-2030	US063100	C. CE. CHP	1000pF 50V B		チップセラコン	01
	C2101	US064100	C. CE. CHP	0.01uF 50V B		チップセラコン	01
	C2102-2105	US044220	C. CE. CHP	0.022uF 25V B		チップセラコン	01
	C2152	UR866100	C. EL	1uF 50V		ケミコン	01
	C2153	UR837470	C. EL	47uF 16V		ケミコン	01
	C2155	US135100	C. CE. CHP	0.1uF 16V		チップセラコン	01
	C2156	US064100	C. CE. CHP	0.01uF 50V B		チップセラコン	01
	C2157	US135100	C. CE. CHP	0.1uF 16V		チップセラコン	01
	C2158	UR866100	C. EL	1uF 50V		ケミコン	01
	C2160	UR866100	C. EL	1uF 50V		ケミコン	01
	C2163	UR837470	C. EL	47uF 16V	UC	ケミコン	01
	C2164	UR837100	C. EL	10uF 16V		ケミコン	01
	C2165-2166	US135100	C. CE. CHP	0.1uF 16V		チップセラコン	01
	C2167	US135100	C. CE. CHP	0.1uF 16V	UC	チップセラコン	01
	C2169-2170	UR866100	C. EL	1uF 50V		ケミコン	01
	C2172-2173	UR866100	C. EL	1uF 50V		ケミコン	01

* New Parts * 新規部品

P.C.B. OPERATION

Ref No.	Part No.	Description	Remarks	Markets	部 品 名	ランク	
	C2175	UR749470 C. EL	4700uF 25V		ケミコン	05	
	C2176	UR749220 C. EL	2200uF 25V		ケミコン	03	
	C2177	UR73A100 C. EL	10000uF 16V	UC	ケミコン	03	
	C2178	UR73A100 C. EL	10000uF 16V		ケミコン	03	
	C2179-2180	VE326000 C. MYLAR	0.1uF 50V		マイラーコン	01	
	C2181	US135100 C. CE. CHP	0.1uF 16V		チップセラコン	01	
*	C2182-2183	WJ605000 C. MYLAR	0.01uF 50V J		マイラーコン		
	C2184	VE326000 C. MYLAR	0.1uF 50V		マイラーコン	01	
	C2251	UR749220 C. EL	2200uF 25V	JUICKABGE	ケミコン	03	
	C2251	UR759220 C. EL	2200uF 35V	RL	ケミコン	02	
*	C2252	WJ605000 C. MYLAR	0.01uF 50V J		マイラーコン		
	C2253	UR897100 C. EL	10uF 100V	RL	ケミコン	01	
*	C2254	WJ605000 C. MYLAR	0.01uF 50V J	JUICKABGE	マイラーコン		
*	C2255-2256	WJ605000 C. MYLAR	0.01uF 50V J	RL	マイラーコン		
△	C2257	WB121400 C. CE. SAFTY	0.01uF 295V		規格認定コン		
*	C2301-2304	WJ605000 C. MYLAR	0.01uF 50V J		マイラーコン		
	C2351-2352	US135100 C. CE. CHP	0.1uF 16V		チップセラコン	01	
	C2353-2354	US062220 C. CE. CHP	220pF 50V B		チップセラコン	01	
*	D2001	WJ249600 LED	ORANGE		L E D		
*	D2003	WJ249600 LED	ORANGE		L E D		
*	D2005	WJ249600 LED	ORANGE		L E D		
*	D2007	WJ249600 LED	ORANGE		L E D		
	D2008-2009	VU171500 DIODE. ZENR	UDZ 3.6BTE-17 3.6V		ツェナーダイオード	01	
	D2151	VT332900 DIODE	1SS355		ダイオード	01	
	D2152	VS997800 DIODE	1T2		ダイオード	01	
	D2154	VT332900 DIODE	1SS355		ダイオード	01	
	D2156	VT332900 DIODE	1SS355		ダイオード	01	
	D2157	VU171900 DIODE. ZENR	UDZ5.1B 5.1V		ツェナーダイオード	01	
	D2158	VS997800 DIODE	1T2		ダイオード	01	
	D2160	VT332900 DIODE	1SS355		ダイオード	01	
	D2161	V2376600 DIODE. SHOT	RB500V-40	UC	ショットキーダイオード	01	
△	D2162	WA653100 DIODE. BRG	KBP103G 1A 200V		ダイオードブリッジ	02	
*	△	D2164	WJ286700 DIODE. BRG	RS403M 4A 140V		ダイオードブリッジ	
	D2165	VU171900 DIODE. ZENR	UDZ5.1B 5.1V		ツェナーダイオード	01	
	D2251	VD631600 DIODE	1SS133, 176		ダイオード	01	
△	D2252	VG437000 DIODE. ZENR	MTZJ4.7A 4.7V	RL	ツェナーダイオード	01	
△	D2253-2254	VS997800 DIODE	1T2		ダイオード	01	
△	D2255	VS997800 DIODE	1T2	RL	ダイオード	01	
△	D2256-2257	VS997800 DIODE	1T2		ダイオード	01	
	D2258-2259	WC398800 DIODE	KDS160-RTK		ダイオード	01	
	D2301	VU172500 DIODE. ZENR	UDZS9.1B		ツェナーダイオード	01	
	D2302-2303	VT332900 DIODE	1SS355		ダイオード	01	
	D2351-2354	VT332900 DIODE	1SS355		ダイオード	01	
△	F2251	WB221200 FUSE	T6A 125V	JUCRL	ヒューズ	01	
△	F2251	VV071700 FUSE	3.15A 250V	TKABGE	ヒューズ	01	
	IC201	X6386A00 IC	M66003-0131FP		I C	07	
△	IC232	X6248A00 IC	NJM2388F33		電源 I C	04	
△	IC233	X4928A00 IC	KIA7805API 5V		電源 I C	02	
△	IC235	X6143A00 IC	NJM2388F05 5.0V	UC	電源 I C	04	
△	IC236	X4153A00 IC	KIA7812API		電源 I C	02	
△	IC237	X4154A00 IC	KIA7912PI		電源 I C		
	IC238	X0515A00 IC	LM61CIZ THERMAL		電源 I C	03	
	JK261	V9408200 JACK. PHONE	MSJ-064-05B GR		ホーンジャック	03	
*	JK266	WJ117400 JACK. MNI	OPTIMIZER MIC		ミニジャック		
*	PJ266	WJ117500 CN	3P		ピンコネクター		

* New Parts * 新規部品

P.C.B. OPERATION and P.C.B. MAIN

Ref No.	Part No.	Description	Remarks	Markets	部 品 名	ランク
PN201-202	V9637500	PIN	L=70 #18		スタイルピン	
PN231-232	V9637500	PIN	L=70 #18		スタイルピン	
PN266	V9637500	PIN	L=70 #18		スタイルピン	
PN272-273	V9637500	PIN	L=70 #18		スタイルピン	
Q2001-2005	VV556400	TR	2SC2412K Q, R, S		トランジスタ	01
Q2011-2012	WC434800	TR. DGT	KRA102S-RTK/P		デジタルトランジスタ	01
Q2013	WC435000	TR. DGT	KRC102S-RTK		デジタルトランジスタ	01
Q2014	VV556400	TR	2SC2412K Q, R, S		トランジスタ	01
Q2015-2016	VV556500	TR	2SA1037K Q, R, S		トランジスタ	01
Q2017	VV556400	TR	2SC2412K Q, R, S		トランジスタ	01
Q2151	WC435100	TR. DGT	KRC104S-RTK		デジタルトランジスタ	01
Q2152	VV556400	TR	2SC2412K Q, R, S		トランジスタ	01
Q2153	WC435100	TR. DGT	KRC104S-RTK		デジタルトランジスタ	01
△ Q2251	VE198800	TR	2SC2705 O, Y		トランジスタ	01
△ Q2252	iA101510	TR	2SA1015 Y	RL	トランジスタ	01
△ Q2253	VP872600	TR	2SA1708 S, T	RL	トランジスタ	01
△ Q2254	iA101510	TR	2SA1015 Y	RL	トランジスタ	01
* △ Q2255	WC529200	TR. DGT	KRC102M-AT	RL	デジタルトランジスタ	01
△ R2163	HV753100	R. CAR. FP	1Ω 1/4W		不燃化カーボン抵抗	01
△ R2169-2170	HV753100	R. CAR. FP	1Ω 1/4W		不燃化カーボン抵抗	01
△ R2174	WH819500	R. FUSE	0.47Ω 1W		ヒューズ抵抗	01
R2258	VC757900	R. MTL. OXD	47Ω 2W	RL	酸化金属被膜抵抗	01
R2260	V6730000	R. CAR.	2.2MΩ 1/2W	UC	放電抵抗	01
* R2301-2302	WJ685600	R. MTL. FLM	470Ω 1W J		金属被膜抵抗	
△ RY251	V9366900	RELAY	DLS9D1-0(M)0.25W		リレー 9V TV-8	05
* ST251	WA789600	SCR. TERM	M3		スクリューターミナル	
* ST261	WA789700	SCR. TERM			スクリューターミナル	01
SW201-220	WD483100	SW. TACT	SKRGAAD010		タクト SW	01
SW221	V9597100	SW. RT. ENC	EC12E2460802		ロータリーエンコーダ	04
△ SW251	VZ075500	SW. SLIDE	SL14-22AM5F	RL	スライドSW	03
SW274	WD483100	SW. TACT	SKRGAAD010		タクト SW	01
* △ T251	X8520A00	TRANS. PWR		J	電源トランス	
* △ T251	X8521A00	TRANS. PWR		UC	電源トランス	
* △ T251	X8522A00	TRANS. PWR		RL	電源トランス	
* △ T251	X8523A00	TRANS. PWR		TKABGE	電源トランス	
* U2002	WJ645300	L. DTCT	SM3385UMH6		リモコン受光ユニット	
* V2001	WJ264400	FL. DSPLY	17-BT-29GNK		蛍光表示管	
	WA790900	SPACER	4.6/10/32		スペーサ FL	
* WJ645400	P. C. B.	MAIN		J	P C B メイン	
* WJ645500	P. C. B.	MAIN		UC	P C B メイン	
* WJ645600	P. C. B.	MAIN		RTA	P C B メイン	
* WJ645700	P. C. B.	MAIN		KL	P C B メイン	
* WJ645800	P. C. B.	MAIN		BGE	P C B メイン	
CB101	VQ962800	CN. BS. PIN	7P		ウエハー	02
CB103	VK025100	CN. BS. PIN	7P		ワイヤートラップ	01
CB104	LB932060	CN. BS. PIN	6P		ベースポスト	01
CB161	VQ047500	CN. BS. PIN	20P		F F Cコネクタ	01
CB163	VM923600	CN. BS. PIN	13P		F F Cコネクタ	01
CB164	VQ963600	CN. BS. PIN	15P		ウエハー	01
CB181	VB858500	CN. BS. PIN	6P	UCRTKABGEL	ベースピン	01
CB191	VB858300	CN. BS. PIN	4P		コネクタベースポスト	01
CB192	VB858400	CN. BS. PIN	5P		ベースピン	01

* New Parts * 新規部品

P.C.B. MAIN

Ref No.	Part No.	Description	Remarks	Markets	部 品 名	ランク	
	CB193	VB858200	CN. BS. PIN	3P		ベースピン	01
*	C1001	WJ605000	C. MYLAR	0.01uF 50V J		マイラーコン	
	C1002-1003	UR837100	C. EL	10uF 16V		ケミコン	01
	C1004	UR866220	C. EL	2.2uF 50V		ケミコン	01
	C1005	UR837100	C. EL	10uF 16V		ケミコン	01
	C1006-1007	UR866220	C. EL	2.2uF 50V		ケミコン	01
	C1008-1009	UR837100	C. EL	10uF 16V		ケミコン	01
	C1010	UR877220	C. EL	22uF 63V		ケミコン	01
*	C1011	WJ603300	C. MYLAR	470pF 50V J		マイラーコン	
△	C1012	UR897100	C. EL	10uF 100V		ケミコン	01
*	△ C1013	WJ603300	C. MYLAR	470pF 50V J		マイラーコン	
	C1014	UR897100	C. EL	10uF 100V		ケミコン	01
	C1015	UR877220	C. EL	22uF 63V		ケミコン	01
	C1016-1017	UR897100	C. EL	10uF 100V		ケミコン	01
*	C1018-1020	WJ603300	C. MYLAR	470pF 50V J		マイラーコン	
*	C1021	WJ602900	C. MYLAR	100pF 50V K		マイラーコン	
	C1022	UR867330	C. EL	33uF 50V		ケミコン	01
*	C1023	WJ602900	C. MYLAR	100pF 50V K		マイラーコン	
	C1024-1025	UR867330	C. EL	33uF 50V		ケミコン	01
*	C1026	WJ602900	C. MYLAR	100pF 50V K		マイラーコン	
	C1027-1028	UR867330	C. EL	33uF 50V		ケミコン	01
*	C1029	WJ602900	C. MYLAR	100pF 50V K		マイラーコン	
	C1030	UR897100	C. EL	10uF 100V		ケミコン	01
*	C1031	WJ602900	C. MYLAR	100pF 50V K		マイラーコン	
	C1032	FG651100	C. CE	10pF 50V		セラコン	01
	C1033	UR866100	C. EL	1uF 50V		ケミコン	01
	C1034-1037	FG650500	C. CE	5pF 50V		セラコン	01
*	C1038-1042	WJ605800	C. MYLAR	0.047uF 50V J		マイラーコン	
	C1043	UR866470	C. EL	4.7uF 50V		ケミコン	01
	C1044	UR828220	C. EL	220uF 10V		ケミコン	01
	C1045	UR858100	C. EL	100uF 35V		ケミコン	01
*	C1046-1047	WJ605400	C. MYLAR	0.022uF 50V J		マイラーコン	
	C1048	UR866470	C. EL	4.7uF 50V		ケミコン	01
	C1049	UR858100	C. EL	100uF 35V		ケミコン	01
*	△ C1050-1051	WE514200	C. EL	6800uF 63V		ケミコン	
*	C1052-1055	WJ605000	C. MYLAR	0.01uF 50V J		マイラーコン	
*	C1056-1057	WJ611400	C. MYLAR	0.1uF 100V J		マイラーコン	
	C1058	UR868100	C. EL	100uF 50V		ケミコン	01
	C1059	US064100	C. CE. CHP	0.01uF 50V B		チップセラコン	01
	C1060	UR837330	C. EL	33uF 16V		ケミコン	01
*	C1501-1505	WJ605400	C. MYLAR	0.022uF 50V J		マイラーコン	
*	C1506-1510	WJ605000	C. MYLAR	0.01uF 50V J		マイラーコン	
*	C1601	WJ605000	C. MYLAR	0.01uF 50V J		マイラーコン	
*	C1602	WJ603300	C. MYLAR	470pF 50V J		マイラーコン	
	C1603	US064100	C. CE. CHP	0.01uF 50V B		チップセラコン	01
	C1606-1617	US062220	C. CE. CHP	220pF 50V B		チップセラコン	01
	C1618-1619	US061470	C. CE. CHP	47pF 50V B		チップセラコン	01
	C1620-1623	US062220	C. CE. CHP	220pF 50V B		チップセラコン	01
	C1624-1625	US061470	C. CE. CHP	47pF 50V B		チップセラコン	01
	C1626-1629	UR837100	C. EL	10uF 16V		ケミコン	01
	C1631	UR866220	C. EL	2.2uF 50V		ケミコン	01
	C1632	US135100	C. CE. CHP	0.1uF 16V		チップセラコン	01
	C1633-1634	UR837100	C. EL	10uF 16V		ケミコン	01
	C1635-1636	UR847470	C. EL	47uF 25V		ケミコン	01
	C1637-1638	UR838100	C. EL	100uF 16V		ケミコン	01

* New Parts * 新規部品

P.C.B. MAIN

Ref No.	Part No.	Description	Remarks	Markets	部 品 名	ランク
C1639-1641	US062100	C. CE. CHP	100pF 50V B		チップセラコン	01
C1642	US064100	C. CE. CHP	0.01uF 50V B		チップセラコン	01
C1643	US063100	C. CE. CHP	1000pF 50V B		チップセラコン	01
C1644	US062100	C. CE. CHP	100pF 50V B		チップセラコン	01
* C1645	WJ605400	C. MYLAR	0.022uF 50V J		マイラーコン	
* C1646	WJ605800	C. MYLAR	0.047uF 50V J		マイラーコン	
C1647	VE326200	C. MYLAR	0.15uF 50V		マイラーコン	
C1648	UR837470	C. EL	47uF 16V		ケミコン	01
* C1649	WJ605400	C. MYLAR	0.022uF 50V J		マイラーコン	
C1650-1655	UR837100	C. EL	10uF 16V		ケミコン	01
C1656	UR837470	C. EL	47uF 16V		ケミコン	01
C1657	VE326200	C. MYLAR	0.15uF 50V		マイラーコン	
C1658	US135100	C. CE. CHP	0.1uF 16V		チップセラコン	01
* C1659	WJ605800	C. MYLAR	0.047uF 50V J		マイラーコン	
C1660	UR837470	C. EL	47uF 16V		ケミコン	01
C1661	US135100	C. CE. CHP	0.1uF 16V	BGE	チップセラコン	01
C1662-1667	UR837100	C. EL	10uF 16V		ケミコン	01
C1668	UR838100	C. EL	100uF 16V		ケミコン	01
C1669	US062330	C. CE. CHP	330pF 50V B	BGE	チップセラコン	01
C1670	UR866220	C. EL	2.2uF 50V		ケミコン	01
* C1671-1674	US162820	C. CE	820pF 50V J		チップセラコン	
* C1675	WJ603600	C. MYLAR	820pF 50V J		マイラーコン	
* C1676	WJ605800	C. MYLAR	0.047uF 50V J		マイラーコン	
C1677-1678	UR837100	C. EL	10uF 16V		ケミコン	01
C1679	US062330	C. CE. CHP	330pF 50V B	BGE	チップセラコン	01
C1680-1682	UR837100	C. EL	10uF 16V		ケミコン	01
C1683-1684	UR837470	C. EL	47uF 16V	BGE	ケミコン	01
C1685-1690	US062100	C. CE. CHP	100pF 50V B		チップセラコン	01
C1691	US062560	C. CE. CHP	560pF 50V B	BGE	チップセラコン	01
* C1692	WJ604400	C. MYLAR	3900pF 50V J		マイラーコン	
C1693-1699	UR837100	C. EL	10uF 16V		ケミコン	01
C1700	US061270	C. CE. CHP	27pF 50V B	BGE	チップセラコン	01
C1701	US135100	C. CE. CHP	0.1uF 16V	BGE	チップセラコン	01
C1702	UR838100	C. EL	100uF 16V		ケミコン	01
C1703	US061270	C. CE. CHP	27pF 50V B	BGE	チップセラコン	01
C1704	UR837470	C. EL	47uF 16V	BGE	ケミコン	01
C1705-1706	UR838100	C. EL	100uF 16V		ケミコン	01
C1707	US135100	C. CE. CHP	0.1uF 16V	BGE	チップセラコン	01
C1801-1803	US060800	C. CE. CHP	8pF 50V B	UCRTKABGEL	チップセラコン	01
C1804-1810	WE773800	C. CE. M. CHP	1uF 10V B	UCRTKABGEL	チップ積層セラコン	01
C1811-1813	US135100	C. CE. CHP	0.1uF 16V	UCRTKABGEL	チップセラコン	01
C1814	UR837470	C. EL	47uF 16V	UCRTKABGEL	ケミコン	01
C1815	WE773800	C. CE. M. CHP	1uF 10V B	UCRTKABGEL	チップ積層セラコン	01
C1816-1817	UR837470	C. EL	47uF 16V	UCRTKABGEL	ケミコン	01
C1818	WE773800	C. CE. M. CHP	1uF 10V B	UCRTKABGEL	チップ積層セラコン	01
C1819	UR829100	C. EL	1000uF 10V	UCRTKABGEL	ケミコン	01
C1820-1821	US062100	C. CE. CHP	100pF 50V B	UCRTKABGEL	チップセラコン	01
C1822	UR829100	C. EL	1000uF 10V	UCRTKABGEL	ケミコン	01
C1823	US063100	C. CE. CHP	1000pF 50V B	UCRTKABGEL	チップセラコン	01
C1824	UR837100	C. EL	10uF 16V	UCRTKABGEL	ケミコン	01
C1825	US063100	C. CE. CHP	1000pF 50V B	UCRTKABGEL	チップセラコン	01
C1826	UR838100	C. EL	100uF 16V	UCRTKABGEL	ケミコン	01
C1827-1829	UR837100	C. EL	10uF 16V	UCRTKABGEL	ケミコン	01
D101-102	VD631600	DIODE	1SS133, 176		ダイオード	01
D103	VU171900	DIODE. ZENR	UDZ5.1B 5.1V		ツェナーダイオード	01

* New Parts * 新規部品

P.C.B. MAIN

Ref No.	Part No.	Description	Remarks	Markets	部 品 名	ランク
D104	WC398800	DIODE	KDS160-RTK		ダイオード	01
D105-106	VN008700	DIODE	1SS270A		ダイオード	01
D107	WC398800	DIODE	KDS160-RTK		ダイオード	01
D108-110	VN008700	DIODE	1SS270A		ダイオード	01
D111-113	VD631600	DIODE	1SS133, 176		ダイオード	01
D114-115	VN008700	DIODE	1SS270A		ダイオード	01
* D116	VG443000	DIODE. ZENR	27. 0V		ツェナーダイオード	
D117	VN008700	DIODE	1SS270A		ダイオード	01
D118-119	VD631600	DIODE	1SS133, 176		ダイオード	01
△ D120	WA653200	DIODE. BRG	TS6P03G 6A 200V		ダイオードブリッジ	04
D121	VD631600	DIODE	1SS133, 176		ダイオード	01
D122-123	VS997800	DIODE	1T2		ダイオード	01
D161-162	VU994300	DIODE. ZENR	MA8075-H 7. 7V		ツェナーダイオード	01
D163	VU995500	DIODE. ZENR	MA8100-H 10. 3V		ツェナーダイオード	02
D181	VU172000	DIODE. ZENR	UDZS5. 6BTE-17 5. 6V	UCRTKABGEL	ツェナーダイオード	01
* △ IC101	X8190A00	IC	STK433-330-E		パワー IC	
* △ IC102	X7427A00	IC	STK433-130-E		アンプ IC	01
* IC161	X8155A00	IC	R2A15215FP		IC	
* IC162-164	X8302A00	IC	AZ4580MTR-E1 OPAMP		アンプ IC	
* IC168	X8235A00	IC	LC72725KM	BGE	IC	
* IC169	X8302A00	IC	AZ4580MTR-E1 OPAMP		アンプ IC	
* IC181	X7362A00	IC	NJM2586AM (TE2)	UCRTKABGEL	アンプ IC	
IC182	XH436A00	IC	LA7956	UCRTKABGEL	IC	03
* PJ161	WJ648900	JACK. PIN	6P		ピンジャック	
* PJ162	WJ649000	JACK. PIN	6P		ピンジャック	
* PJ163	WJ649300	JACK. PIN	1P		ピンジャック	
* PJ164-165	WJ649200	JACK. PIN	4P		ピンジャック	
* PJ181-182	WG505100	JACK. PIN	6P	UCRTKABGEL	ピンジャック	
* PJ183	WJ649100	JACK. PIN	2P	UCRTKABGEL	ピンジャック	
* PJ184	WJ649400	JACK. PIN	1P	UCRTKABGEL	ピンジャック	
* PJ185	WJ649100	JACK. PIN	2P	UCRTKABGEL	ピンジャック	
PN191-192	V9637500	PIN	L=70 #18		スタイルピン	
Q101-105	VD303700	TR	2SC3326 A, B		トランジスタ	01
Q106-108	WC434800	TR. DGT	KRA102S-RTK/P		デジタルトランジスタ	01
△ Q109	WC398400	TR	2N5551C-AT		トランジスタ	
△ Q110-111	VC614000	TR	2SB1274 Q, R, S		トランジスタ	02
△ Q112	WC398400	TR	2N5551C-AT		トランジスタ	
△ Q113-114	WC397700	TR	2N5401C-AT		トランジスタ	
△ Q115-119	WC398400	TR	2N5551C-AT		トランジスタ	
△ Q120	WC397700	TR	2N5401C-AT		トランジスタ	
△ Q121-123	WC434900	TR. DGT	KRA104S-RTK		デジタルトランジスタ	01
△ Q124	VP872600	TR	2SA1708 S, T		トランジスタ	01
△ Q125-126	WC434900	TR. DGT	KRA104S-RTK		デジタルトランジスタ	01
△ Q127	WC435000	TR. DGT	KRC102S-RTK		デジタルトランジスタ	01
Q128	iC181510	TR	2SC1815 Y		トランジスタ	01
Q129-132	WC435000	TR. DGT	KRC102S-RTK		デジタルトランジスタ	01
Q133	WC434900	TR. DGT	KRA104S-RTK		デジタルトランジスタ	01
Q161-162	VZ725900	TR	2SD1938F S, T		トランジスタ	01
Q163	WC434800	TR. DGT	KRA102S-RTK/P		デジタルトランジスタ	01
Q164	iC181510	TR	2SC1815 Y		トランジスタ	01
Q165	iA101510	TR	2SA1015 Y		トランジスタ	01
Q166	iC181510	TR	2SC1815 Y		トランジスタ	01
Q167	iC174020	TR	2SC1740S QRS	BGE	トランジスタ	01
Q181	iA101510	TR	2SA1015 Y	UCRTKABGEL	トランジスタ	01
Q182	iC174020	TR	2SC1740S QRS	UCRTKABGEL	トランジスタ	01

* New Parts * 新規部品

P.C.B. MAIN and P.C.B. D-VIDEO

Ref No.	Part No.	Description	Remarks	Markets	部 品 名	ランク	
Q183-184	iC181510	TR	2SC1815 Y		UCRTKABGEL	トランジスタ	01
R1027-1028	HV753220	R. CAR. FP	2.2Ω 1/4W			不燃化カーボン抵抗	01
△ R1031	HV755560	R. CAR. FP	560Ω 1/4W			不燃化カーボン抵抗	01
△ R1038	HV754100	R. CAR. FP	10Ω 1/4W			不燃化カーボン抵抗	01
△ R1043	HV754100	R. CAR. FP	10Ω 1/4W			不燃化カーボン抵抗	01
△ R1054	WB279900	R. CEMENT	RGC55C 0.22+0.22			セメント抵抗	02
△ R1057	WB279900	R. CEMENT	RGC55C 0.22+0.22			セメント抵抗	02
△ R1061	WB279900	R. CEMENT	RGC55C 0.22+0.22			セメント抵抗	02
△ R1069-1070	WB279900	R. CEMENT	RGC55C 0.22+0.22			セメント抵抗	02
R1085	HV754100	R. CAR. FP	10Ω 1/4W			不燃化カーボン抵抗	01
R1087	HV754100	R. CAR. FP	10Ω 1/4W			不燃化カーボン抵抗	01
R1089	HV754100	R. CAR. FP	10Ω 1/4W			不燃化カーボン抵抗	01
R1092-1093	HV754100	R. CAR. FP	10Ω 1/4W			不燃化カーボン抵抗	01
* △ R1095	WB625100	R. MTL. FLM	4.7Ω 1W J			金属被膜抵抗	
* △ R1099-1100	WB625100	R. MTL. FLM	4.7Ω 1W J			金属被膜抵抗	
* △ R1103-1104	WB625100	R. MTL. FLM	4.7Ω 1W J			金属被膜抵抗	
△ R1106	HV756390	R. CAR. FP	3.9KΩ 1/4W			不燃化カーボン抵抗	01
R1107	HV753470	R. CAR. FP	4.7Ω 1/4W			不燃化カーボン抵抗	01
* △ R1110	WB627600	R. MTL. OXD	820Ω 1W J			酸化金属被膜抵抗	
R1111	HV753470	R. CAR. FP	4.7Ω 1/4W			不燃化カーボン抵抗	01
R1501-1505	HV753470	R. CAR. FP	4.7Ω 1/4W			不燃化カーボン抵抗	01
R1659-1660	HV753220	R. CAR. FP	2.2Ω 1/4W			不燃化カーボン抵抗	01
R1815	HV754220	R. CAR. FP	22Ω 1/4W		UCRTKABGEL	不燃化カーボン抵抗	01
R1825	HV755270	R. CAR. FP	270Ω 1/4W		UCRTKABGEL	不燃化カーボン抵抗	01
R1831	HV753220	R. CAR. FP	2.2Ω 1/4W		UCRTKABGEL	不燃化カーボン抵抗	01
* △ RY101-105	WJ122400	RELAY	981-2A-24DS-SP7			リレー 24V	
RY106	WE648700	RELAY	DC DH24D2-0-Q			リレー 24V	06
ST101	WA789600	SCR. TERM	M3			スクリューターミナル	
* TE101	WJ265400	TERM. SP	JB-405ET(V0)-02		JUCRTA	スピーカ端子	
* TE101	WJ265500	TERM. SP	JB-408A(V0)-01		KBGEL	スピーカ端子	
* TE151	WJ551900	TERM. SP	MSP-120V2-11(765A)			スピーカ端子	
* XL161	WJ588000	RSNR. CRYST	4.332MHz		BGE	水晶振動子	
	WE774200	SCR. BND. HD	3x10 MFZ2W3			バインドBタイトネジ	01
* WJ645000	P. C. B.	D-VIDEO			J	P C B Dビデオ	
CB301-304	WD398400	CN. DIN	14P YKF45-3011		J	D I Nコネクター	05
CB305	VB858500	CN. BS. PIN	6P		J	ベースピン	01
C3003-3011	US060800	C. CE. CHP	8pF 50V B		J	チップセラコン	01
C3012-3014	US064100	C. CE. CHP	0.01uF 50V B		J	チップセラコン	01
C3015-3017	US060800	C. CE. CHP	8pF 50V B		J	チップセラコン	01
C3026-3030	US135100	C. CE. CHP	0.1uF 16V		J	チップセラコン	01
C3031	UR837470	C. EL	47uF 16V		J	ケミコン	01
C3032	US135100	C. CE. CHP	0.1uF 16V		J	チップセラコン	01
C3033	UR837470	C. EL	47uF 16V		J	ケミコン	01
C3034	US135100	C. CE. CHP	0.1uF 16V		J	チップセラコン	01
C3035	UR837470	C. EL	47uF 16V		J	ケミコン	01
C3036-3037	US135100	C. CE. CHP	0.1uF 16V		J	チップセラコン	01
C3038-3040	US061220	C. CE. CHP	22pF 50V B		J	チップセラコン	01
C3041-3042	US135100	C. CE. CHP	0.1uF 16V		J	チップセラコン	01
C3043-3044	UR837100	C. EL	10uF 16V		J	ケミコン	01
C3045	UR838100	C. EL	100uF 16V		J	ケミコン	01
C3046-3049	UR837100	C. EL	10uF 16V		J	ケミコン	01
C3050	US063100	C. CE. CHP	1000pF 50V B		J	チップセラコン	01

* New Parts * 新規部品

P.C.B. D-VIDEO

Ref No.	Part No.	Description	Remarks	Markets	部 品 名	ランク
C3051	UR838100	C.EL	100uF 16V	J	ケミコン	01
C3052	UR837100	C.EL	10uF 16V	J	ケミコン	01
C3053-3054	US062100	C.CE. CHP	100pF 50V B	J	チップセラコン	01
C3055-3056	UR829100	C.EL	1000uF 10V	J	ケミコン	01
C3057	US063100	C.CE. CHP	1000pF 50V B	J	チップセラコン	01
D3001-3009	VT332900	DIODE	1SS355	J	ダイオード	01
IC303	X2904A00	IC	NJM2581M VIDEO AMP	J	アンプIC	06
IC304-306	XS790A00	IC	TC74HC4052AF MPX	J	ロジックIC	02
IC307	XH436A00	IC	LA7956	J	IC	03
IC308	X7973A00	IC	K1A79M05P1-U	J	電源IC	02
PJ301	V7190000	JACK. PIN	2P	J	ピンジャック	
PJ302	V7189800	JACK. PIN	1P	J	ピンジャック	01
PJ303	V7190000	JACK. PIN	2P	J	ピンジャック	
Q301-302	iC181510	TR	2SC1815 Y	J	トランジスタ	01
Q303	iC174020	TR	2SC1740S QRS	J	トランジスタ	01
R3044	HV755270	R. CAR. FP	270Ω 1/4W	J	不燃化カーボン抵抗	01
R3049	HV753220	R. CAR. FP	2.2Ω 1/4W	J	不燃化カーボン抵抗	01

Carbon Resistors

Value	1/4W Type Part No.	1/6W Type Part No.	Value	1/4W Type Part No.	1/6W Type Part No.
1.0 Ω	HJ35 3100	HF85 3100	10 kΩ	HF45 7100	HF45 7100
1.8 Ω	HJ35 3180	*	11 kΩ	HF45 7110	HF45 7110
2.2 Ω	HJ35 3220	HF85 3220	12 kΩ	HJ35 7120	HF85 7120
3.3 Ω	HJ35 3330	HF85 3330	13 kΩ	HF45 7130	HF45 7130
4.7 Ω	HJ35 3470	HF85 3470	15 kΩ	HF45 7150	HF45 7150
5.6 Ω	HJ35 3560	HF85 3560	18 kΩ	HF45 7180	HF45 7180
10 Ω	HF45 4100	HF45 4100	22 kΩ	HF45 7220	HF45 7220
15 Ω	HJ35 4150	HF85 4150	24 kΩ	HF45 7240	HF45 7240
22 Ω	HF45 4220	HF45 4220	27 kΩ	HJ35 7270	HF85 7270
27 Ω	HJ35 4270	HF85 4270	30 kΩ	HF45 7300	HF45 7300
33 Ω	HF45 4330	HF45 4330	33 kΩ	HF45 7330	HF45 7330
39 Ω	HJ35 4470	HF85 4390	36 kΩ	HF45 7360	HF45 7360
47 Ω	HF45 4470	HF45 4470	39 kΩ	HF45 7390	HF45 7390
56 Ω	HF45 4560	HF45 4560	47 kΩ	HF45 7470	HF45 7470
68 Ω	HF45 4680	HF45 4680	51 kΩ	HF45 7510	HF45 7510
75 Ω	HF45 4750	HF45 4750	56 kΩ	HF45 7560	HF45 7560
82 Ω	HF45 4820	HF45 4820	62 kΩ	HF45 7620	HF45 7620
91 Ω	HF45 4910	HF45 4910	68 kΩ	HF45 7680	HF45 7680
100 Ω	HF45 5100	HF45 5100	82 kΩ	HF45 7820	HF45 7820
110 Ω	HJ35 5110	HF85 5110	91 kΩ	HF45 7910	HF45 7910
120 Ω	HF45 5120	HF45 5120	100 kΩ	HF45 8100	HF45 8100
150 Ω	HF45 5150	HF45 5150	110 kΩ	HF45 8110	HF45 8110
160 Ω	HJ35 5160	*	120 kΩ	HF45 8120	HF45 8120
180 Ω	HF45 5180	HF45 5180	150 kΩ	HF45 8150	HF45 8150
200 Ω	HF45 5200	HF45 5200	180 kΩ	HF45 8180	HF45 8180
220 Ω	HF45 5220	HF45 5220	220 kΩ	HJ35 8220	HF85 8220
270 Ω	HF45 5270	HF45 5270	270 kΩ	HF45 8270	HF45 8270
330 Ω	HF45 5330	HF45 5330	300 kΩ	HF45 8300	HF45 8300
390 Ω	HF45 5390	HF45 5390	330 kΩ	HF45 8330	HF45 8330
430 Ω	HF45 5430	HF45 5430	390 kΩ	HJ35 8390	HF85 8390
470 Ω	HF45 5470	HF45 5470	470 kΩ	HF45 8470	HF45 8470
510 Ω	HF45 5510	HF45 5510	560 kΩ	HJ35 8560	HF85 8560
560 Ω	HF45 5560	HF45 5560	680 kΩ	HJ35 8680	HF85 8680
680 Ω	HF45 5680	HF45 5680	820 kΩ	HJ35 8820	HF85 8820
820 Ω	HF45 5820	HF45 5820	1.0 MΩ	HF45 9100	HF45 9100
910 Ω	HF45 5910	HF45 5910	1.2 MΩ	HJ35 9120	*
1.0 kΩ	HF45 6100	HF45 6100	1.5 MΩ	HJ35 9150	HF85 9150
1.2 kΩ	HF45 6120	HF45 6120	1.8 MΩ	HJ35 9180	HF85 9180
1.5 kΩ	HF45 6150	HF45 6150	2.2 MΩ	HJ35 9220	HF85 9220
1.8 kΩ	HF45 6180	HF45 6180	3.3 MΩ	HJ35 9330	HF85 9330
2.0 kΩ	HJ35 6200	HF85 6200	3.9 MΩ	HJ35 9390	*
2.2 kΩ	HF45 6220	HF45 6220	4.7 MΩ	HJ35 9470	HF85 9470
2.4 kΩ	HJ35 6240	HF85 6240			
2.7 kΩ	HF45 6270	HF45 6270			
3.0 kΩ	HF45 6300	HF45 6300			
3.3 kΩ	HF45 6330	HF45 6330			
3.6 kΩ	HJ35 6360	HF85 6360			
3.9 kΩ	HF45 6390	HF45 6390			
4.7 kΩ	HF45 6470	HF45 6470			
5.1 kΩ	HF45 6510	HF45 6510			
5.6 kΩ	HF45 6560	HF45 6560			
6.8 kΩ	HF45 6680	HF45 6680			
8.2 kΩ	HF45 6820	HF45 6820			
9.1 kΩ	HF45 6910	HF45 6910			

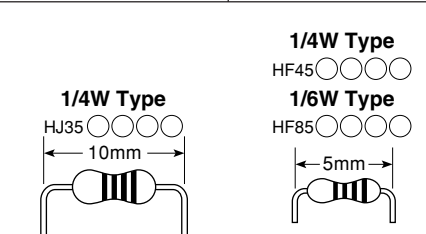

* New Parts * 新規部品

* : Not available

• OVERALL ASS'Y

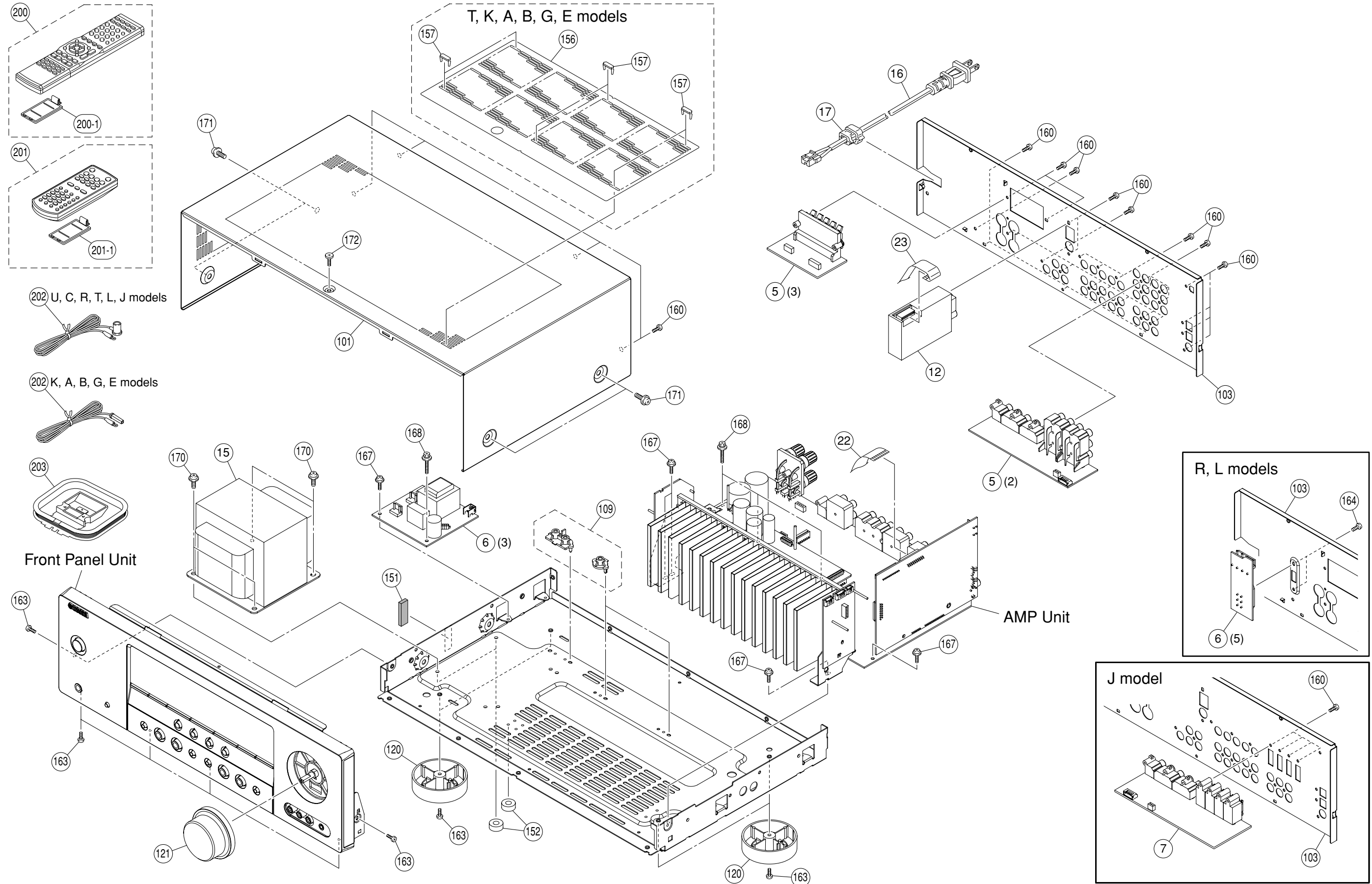

Ref No.	Part No.	Description	Remarks	Markets	部 品 名	ランク	
*	5	WJ645400	P. C. B. ASS'Y	MAIN	J	P C B メイン	
*	5	WJ645500	P. C. B. ASS'Y	MAIN	UC	P C B メイン	
*	5	WJ645600	P. C. B. ASS'Y	MAIN	RTA	P C B メイン	
*	5	WJ645700	P. C. B. ASS'Y	MAIN	KL	P C B メイン	
*	5	WJ645800	P. C. B. ASS'Y	MAIN	BGE	P C B メイン	
*	6	WJ643600	P. C. B. ASS'Y	OPERATION	J	P C B オペレーション	
*	6	WJ643700	P. C. B. ASS'Y	OPERATION	UC	P C B オペレーション	
*	6	WJ643800	P. C. B. ASS'Y	OPERATION	R	P C B オペレーション	
*	6	WJ643900	P. C. B. ASS'Y	OPERATION	TKABGE	P C B オペレーション	
*	6	WJ644000	P. C. B. ASS'Y	OPERATION	L	P C B オペレーション	
*	7	WJ645000	P. C. B. ASS'Y	D-VIDEO	J	P C B Dビデオ	
	12	WB423900	AM/FM TUNER	ENG04705Q	J	AM/FM チューナー	12
	12	WB424000	AM/FM TUNER	ENG06709Q	UCRL	AM/FM チューナー	
	12	WB877300	AM/FM TUNER	FAE381-A07F	T	AM/FM チューナー	
	12	WB424100	AM/FM TUNER	ENG07711Q	KABGE	AM/FM チューナー	
* ⚠	15	X8599A00	POWER TRANSFORMER		J	電源トランス	
* ⚠	15	X8600A00	POWER TRANSFORMER		UC	電源トランス	
* ⚠	15	X8601A00	POWER TRANSFORMER		RL	電源トランス	
* ⚠	15	X8602A00	POWER TRANSFORMER		TK	電源トランス	
* ⚠	15	X8603A00	POWER TRANSFORMER		A	電源トランス	
* ⚠	15	X8604A00	POWER TRANSFORMER		BGE	電源トランス	
⚠	16	WB211800	POWER CABLE	1.8m	J	電源コード	
⚠	16	WB120500	POWER CABLE	2m	UC	電源コード	
⚠	16	WC992700	POWER CABLE	2m	R	電源コード	
⚠	16	WB120600	POWER CABLE	2m	T	電源コード	
⚠	16	WC753000	POWER CABLE	2m	K	電源コード	
⚠	16	WC743700	POWER CABLE	2m	A	電源コード	
⚠	16	WB212200	POWER CABLE	2m	B	電源コード	
⚠	16	WB212300	POWER CABLE	2m	GEL	電源コード	
	17	V2438700	CORD STOPPER	10P1		コードストッパー	02
	22	MF120180	FLEXIBLE FLAT CABLE	20P 180mm P=1.25		カード電線 C & C	03
	23	MF113120	FLEXIBLE FLAT CABLE	13P 120mm P=1.25		カード電線 C & C	01
	101	WE065200	TOP COVER		GD	トップカバー	
	101	WE065000	TOP COVER		BL	トップカバー	
	101	WE065100	TOP COVER		TI	トップカバー	
	101	WG481900	TOP COVER		SI	トップカバー	
*	103	WJ187000	REAR PANEL	AX361	J	リヤパネル	
*	103	WJ186400	REAR PANEL	V361	UC	リヤパネル	
*	103	WJ186500	REAR PANEL	V361	R	リヤパネル	
*	103	WJ186600	REAR PANEL	V361	T	リヤパネル	
*	103	WJ213400	REAR PANEL	V361	K	リヤパネル	
*	103	WJ186700	REAR PANEL	V361	A	リヤパネル	
*	103	WJ186800	REAR PANEL	V361	BGE	リヤパネル	
*	103	WJ186900	REAR PANEL	V361	L	リヤパネル	
*	103	WJ187100	REAR PANEL	6030	UC	リヤパネル	
*	103	WJ187200	REAR PANEL	6030	R	リヤパネル	
*	103	WJ187300	REAR PANEL	6030	T	リヤパネル	
*	103	WJ213500	REAR PANEL	6030	K	リヤパネル	
*	103	WJ187400	REAR PANEL	6030	A	リヤパネル	
*	103	WJ187500	REAR PANEL	6030	GE	リヤパネル	
	109	WA796100	SUPPORT P. C. B.			サポート P C B	
	120	WA790600	LEG	D60/H21	GD	レッグ	
	120	WA790500	LEG	D60/H21	V361BL, TI, SI	レッグ	
	120	WA790700	LEG	D60/H21	6030BL	レッグ	
	121	WG362100	KNOB D48	VOLUME	GD	ノブ D 4 8	
	121	WG362000	KNOB D48	VOLUME	BL	ノブ D 4 8	
	121	WG466100	KNOB D48	VOLUME	TI	ノブ D 4 8	
	121	WG362200	KNOB D48	VOLUME	SI	ノブ D 4 8	
	151	WB408400	DAMPER	10x30 t=4		ダンパー	

* New Parts * 新規部品

Ref No.	Part No.	Description	Remarks	Markets	部 品 名	ランク	
*	152	WB484700	DAMPER			SCREW MASK	
*	156	WJ589800	SHEET TOP		TKABGE	シート トップ	
*	157	WJ323900	RIVET TOP		TKABGE	リベット トップ	
	160	WE774100	BIND HEAD BONDING B-T. SCREW	3x8 MFZN2B3		ボンディング B タイトネジ	01
	163	WE774300	BIND HEAD B-TIGHT SCREW	3x8 MFZN2W3		バインド B タイトネジ	01
	164	WE774000	BIND HEAD SCREW	3x6 MFZN2W3	RL	バインド小ネジ	01
	167	WF002600	PW HEAD B-TIGHT SCREW	3x8 MFZN2W3		PWヘッド B タイトネジ	01
	168	WE774600	SCREW IC	3x18 MFZN2W3		スクリュー IC	01
	170	WE774700	BIND HEAD S-TIGHT SCREW	4x10 MFZN2W3		バインド S タイトネジ	01
	171	VD069600	PW HEAD S-TIGHT SCREW	4x8-10 MFN133	GD, TI, SI	PWヘッド S タイトネジ	01
	171	VH313200	PW HEAD S-TIGHT SCREW	4x8-10 MFN13BL	BL	PWヘッド S タイトネジ	01
	172	WE200400	DISH HEAD B-TIGHT SCREW	3x6 MFN133	GD, TI, SI	D I S H B タイトネジ	01
	172	WE200500	DISH HEAD B-TIGHT SCREW	3x6 MFN13BL	BL	D I S H B タイトネジ	01
			ACCESSORIES			付属品	
*	200	WJ409400	REMOTE CONTROL	RAV312	JRTKAL	リモコン	
*	200	WJ409300	REMOTE CONTROL	RAV311	UC	リモコン	
*	200-1	AAX82380	BATTERY COVER		CG-2209	JUCRTKAL	電池蓋
*	201	WJ409700	REMOTE CONTROL	RAV28	BGE	リモコン	
*	201-1	AAX70730	BATTERY COVER		CG-8912	BGE	電池蓋
	202	WB212500	INDOOR FM ANTENNA	1.4m 1pc	JUCRTL	F M簡易アンテナ	03
	202	WB212400	INDOOR FM ANTENNA	1.4m 1pc	KABGE	F M簡易アンテナ	
	203	WB212600	AM LOOP ANTENNA	1.0m 1pc		A Mループアンテナ	04
			BATTERY MANGANESE DRY	R03,AAA,UM-4 2pcs		単 4 乾電池	
			SERVICE TOOLS				
		V2854400	FLEXIBLE FLAT CABLE	17P 300mm P=1.25		カード電線 C & C	

* New Parts * 新規部品

1 • AMP UNIT

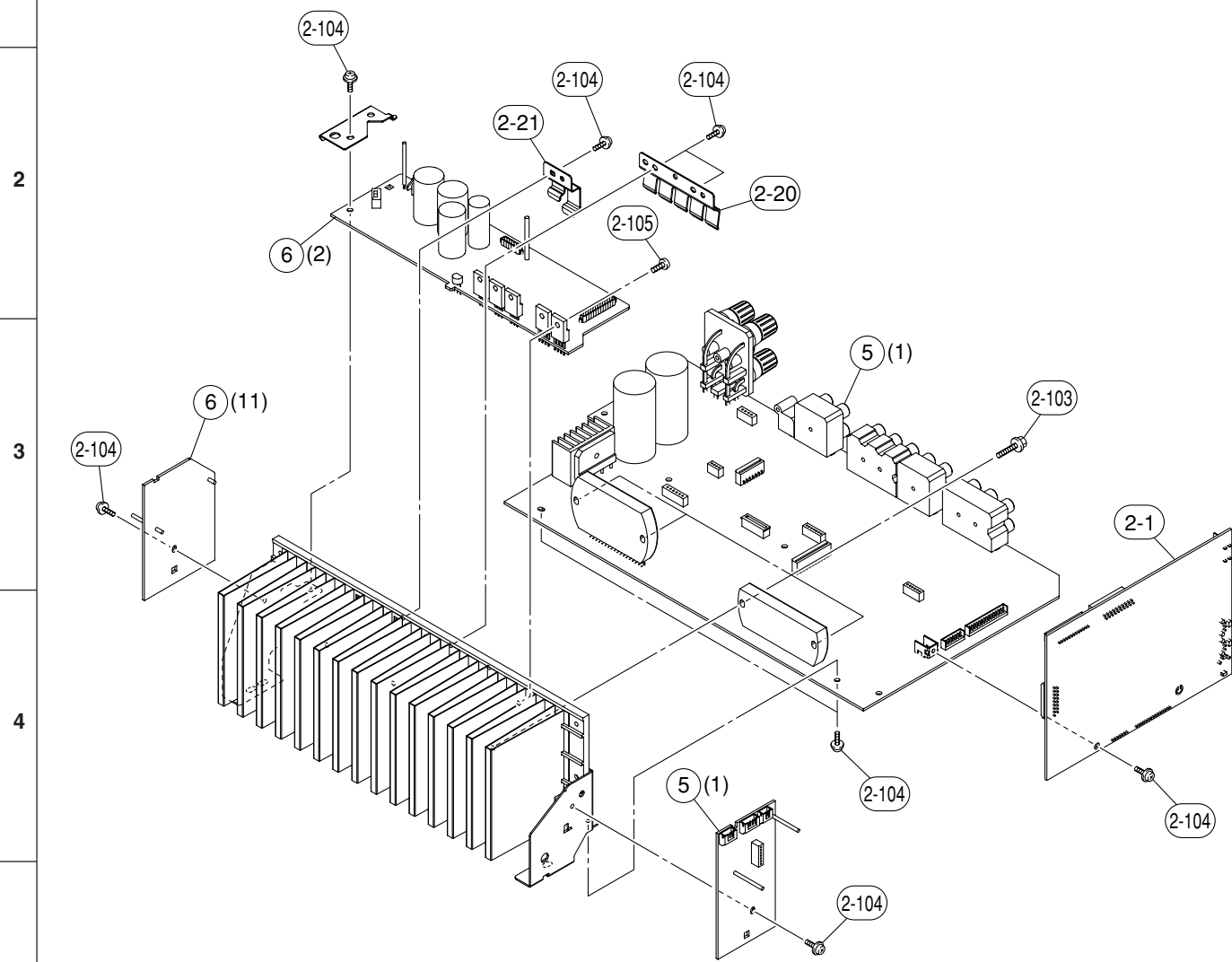

Ref No.	Part No.	Description	Remarks	Markets	部品名	ランク	
*	2-1	WJ641900	P.C.B. ASS'Y	DSP	J	PCB DSP	
*	2-1	WJ642000	P.C.B. ASS'Y	DSP	UC	PCB DSP	
*	2-1	WJ642100	P.C.B. ASS'Y	DSP	R	PCB DSP	
*	2-1	WJ642200	P.C.B. ASS'Y	DSP	T	PCB DSP	
*	2-1	WJ642300	P.C.B. ASS'Y	DSP	KA	PCB DSP	
*	2-1	WJ642400	P.C.B. ASS'Y	DSP	BGE	PCB DSP	
*	2-1	WJ642500	P.C.B. ASS'Y	DSP	L	PCB DSP	
	2-20	WG451000	SUPPORT TR	5P		サポートTR 5P	
*	2-21	WJ187700	SUPPORT TR	2P		サポートTR 2P	
	2-103	WE774600	SCREW IC	3x18	MFZN2W3	スクリューIC	01
	2-104	WF002600	PW HEAD B-TIGHT SCREW	3x8	MFZN2W3	PWヘッドBタイトネジ	01
	2-105	WE774300	BIND HEAD B-TIGHT SCREW	3x8	MFZN2W3	バインドBタイトネジ	01
*	5	WJ645400	P.C.B. ASS'Y	MAIN	J	PCB メイン	
*	5	WJ645500	P.C.B. ASS'Y	MAIN	UC	PCB メイン	
*	5	WJ645600	P.C.B. ASS'Y	MAIN	RTA	PCB メイン	
*	5	WJ645700	P.C.B. ASS'Y	MAIN	KL	PCB メイン	
*	5	WJ645800	P.C.B. ASS'Y	MAIN	BGE	PCB メイン	
*	6	WJ643600	P.C.B. ASS'Y	OPERATION	J	PCB オペレーション	
*	6	WJ643700	P.C.B. ASS'Y	OPERATION	UC	PCB オペレーション	
*	6	WJ643800	P.C.B. ASS'Y	OPERATION	R	PCB オペレーション	
*	6	WJ643900	P.C.B. ASS'Y	OPERATION	TKABGE	PCB オペレーション	
*	6	WJ644000	P.C.B. ASS'Y	OPERATION	L	PCB オペレーション	

* New Parts * 新規部品

REMOTE CONTROL

● RAV311 RX-V361 (U, C models), HTR-6030 (U, C models)

RAV312 RX-V361 (R, T, K, A, L models), HTR-6030 (R, T, K, A models), DSP-AX361 (J model)

• SCHEMATIC DIAGRAM

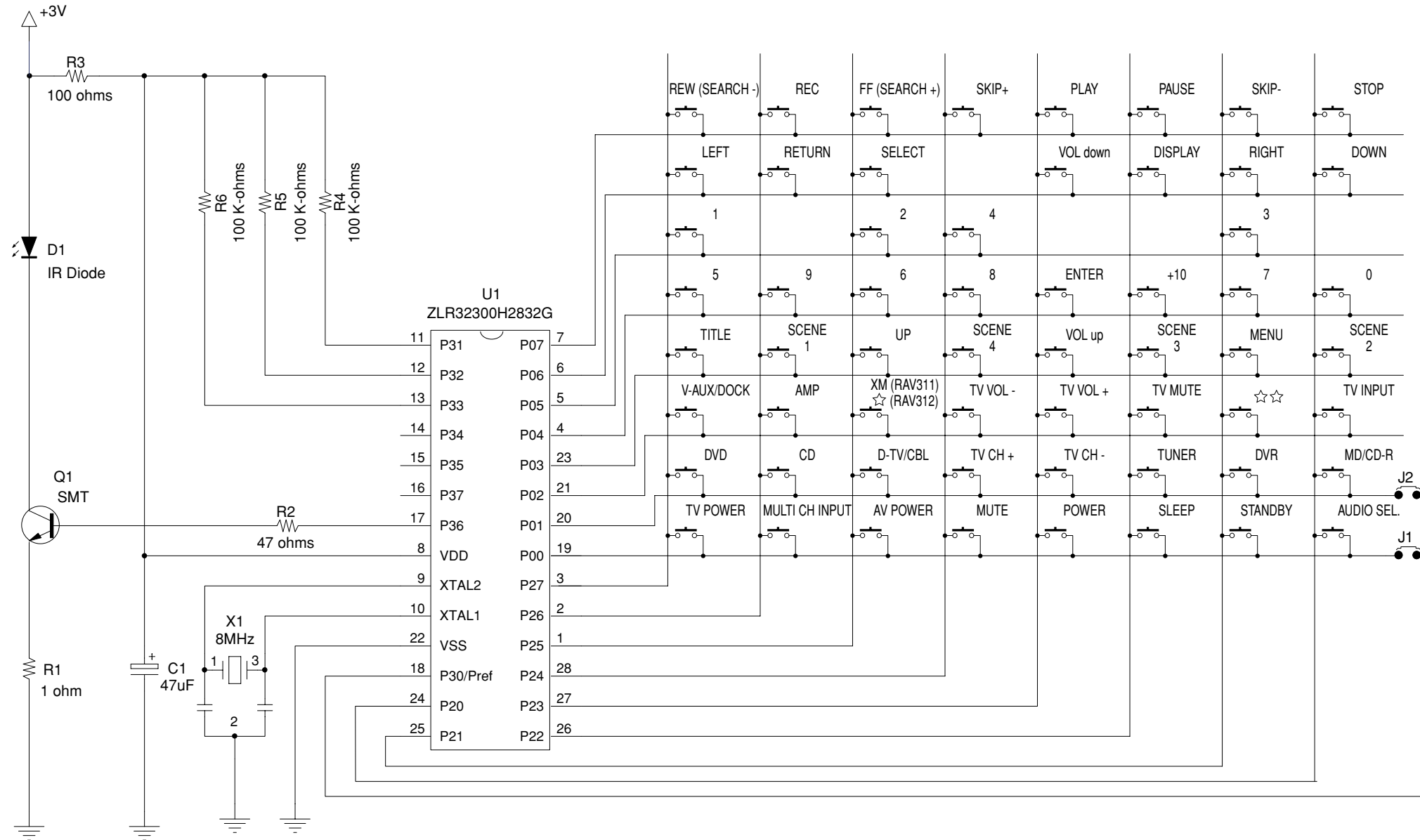

• PANELS

RAV311

RX-V361 (U, C models)
HTR-6030 (U, C models)

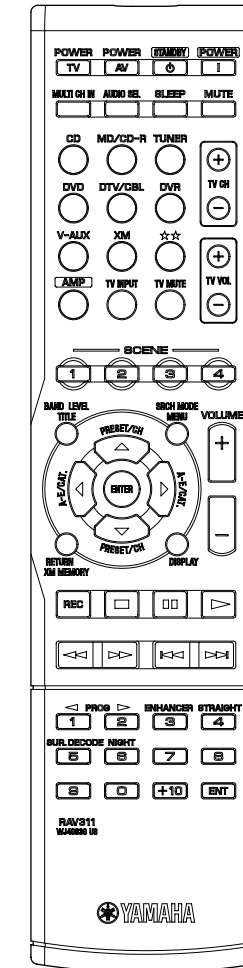

RAV312

RX-V361 (R, T, K, A, L models)
HTR-6030 (R, T, K, A models)
DSP-AX361 (J model)

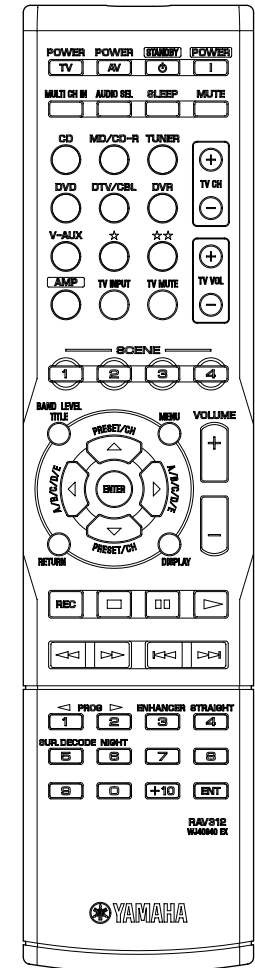

1 • KEY NO. LAYOUT

• KEY CODE

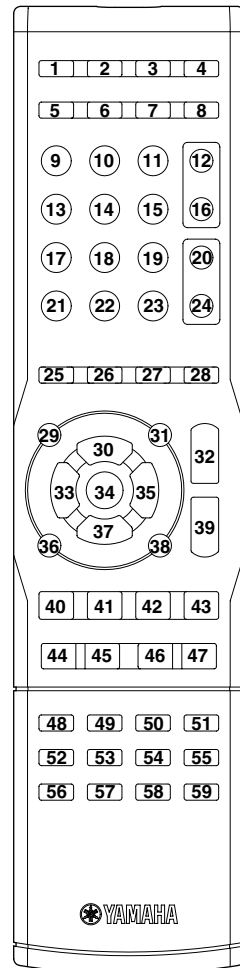

Key No.	Label	Command key	YAMAHA signal													Default		
			AMP	(TV Power)	(TV Power)	(TV Power)	(TV Power)	-	(TV Power)	(TV Power)	(TV Power)	(TV Power)	(TV Power)	(TV Power)	(TV Power)	Library	brand	
1	TV POWER	-	-	(TV Power)	(TV Power)	(TV Power)	(TV Power)	-	(TV Power)	(TV Power)	(TV Power)	(TV Power)	(TV Power)	(TV Power)	(TV Power)	(TV Power)	(TV Power)	(TV Power)
2	AV POWER	-	-	-	7F80	-	7F80	(DVR Power)	048.012	7F01-00	-	-	7F01-20	-	-	-	(device)	
3	STANDBY	O	7E-7F	STANDBY														
4	POWER	O	7E-7E	POWER ON														
5	MULTI CH INPUT	O	7A-87	MULTI CH INPUT														
6	AUDIO SEL.	O	7A-C3	AUDIO SELECT														
7	SLEEP	O	7A-57	SLEEP														
8	MUTE	O	7A-IC	MUTE														
9	CD	O	7A-15	<INPUT key>	Output IR signal and change Device mode											CD	YAMAHA-1	
10	MD/CD-R	O	7A-C9	<INPUT key>	Output IR signal and change Device mode											CD-R	YAMAHA	
11	TUNER	O	7A-16	<INPUT key>	Output IR signal and change Device mode											TUNER	YAMAHA-2	
12	TV CH +	-	-	(TV CH +)	(TV CH +)	(TV CH +)	(TV CH +)	-	(TV CH +)	(TV CH +)	(TV CH +)	(TV CH +)	(TV CH +)	(TV CH +)	(TV CH +)	(TV CH +)	(TV CH +)	
13	DVD	O	7A-C1	<INPUT key>	Output IR signal and change Device mode											DVD	YAMAHA-1	
14	D-TV/CBL	O	7A-54	<INPUT key>	Output IR signal and change Device mode											TV	YAMAHA1	
15	DVR	O	7A-13	<INPUT key>	Output IR signal and change Device mode											DVR	YAMAHA	
16	TV CH -	-	-	(TV CH -)	(TV CH -)	(TV CH -)	(TV CH -)	-	(TV CH -)	(TV CH -)	(TV CH -)	(TV CH -)	(TV CH -)	(TV CH -)	(TV CH -)	(TV CH -)	(TV CH -)	
17	V-AUX/DOCK	O	7A-55	<INPUT key>	Output IR signal and change Device mode											TUNER	YAMAHA-6	
18	XM (RAV311) ☆ (RAV312)	O	7A-B4	<INPUT key>	Output IR signal and change Device mode											TUNER	YAMAHA-4	
19	☆☆	O	7F01-3F	<INPUT key>	Output IR signal and change Device mode											TAPE	YAMAHA-1	
20	TV VOL +	-	-	(TV VOL +)	(TV VOL +)	(TV VOL +)	(TV VOL +)	-	(TV VOL +)	(TV VOL +)	(TV VOL +)	(TV VOL +)	(TV VOL +)	(TV VOL +)	(TV VOL +)	(TV VOL +)	(TV VOL +)	
21	AMP	O	-	Change to AMP mode														
			Key No Mode	9	10	11	13	14	15	17	18	19	21					
				CD	MD/CD-R	TUNER	DVD	D-TV/CBL	DVR	V-AUX/DOCK	XM	NET/USB	AMP					
22	TV INPUT	-	-	(TV Input)	(TV Input)	(TV Input)	(TV Input)	-	(TV Input)	(TV Input)	(TV Input)	(TV Input)	(TV Input)	(TV Input)	(TV Input)	(TV Input)	(TV Input)	
23	TV MUTE	-	-	(TV Mute)	(TV Mute)	(TV Mute)	(TV Mute)	-	(TV Mute)	(TV Mute)	(TV Mute)	(TV Mute)	(TV Mute)	(TV Mute)	(TV Mute)	(TV Mute)	(TV Mute)	
24	TV VOL -	-	-	(TV VOL -)	(TV VOL -)	(TV VOL -)	(TV VOL -)	-	(TV VOL -)	(TV VOL -)	(TV VOL -)	(TV VOL -)	(TV VOL -)	(TV VOL -)	(TV VOL -)	(TV VOL -)	(TV VOL -)	
25	SCENE 1	O	7A-007F	SCENE SELECT														
26	SCENE 2	O	7A-037C	SCENE SELECT														
27	SCENE 3	O	7A-0679	SCENE SELECT														
28	SCENE 4	O	7A-0976	SCENE SELECT														
29	TITLE	-	-	-	-	7A-AE	7CB1	-	048.200	7F01-0D	7A-70	-	7F01-2D	-	7A-86			
30	UP	-	-	-	-	7A-10	7CB4	-	048.088	7F01-0E	7A-6A	-	7F01-2E	-	7A-9D			
31	MENU	-	-	-	-	7A-AB	7CB2	-	048.084	7F01-0F	7A-6D	-	7F01-2F	-	7A-84			
32	VOL up	O	7A-1A	VOL UP														
33	LEFT	-	-	-	-	7A-AC	7CB5	-	048.090	7F01-10	7A-6E	-	7F01-30	-	7A-9F			
34	SELECT	-	-	-	-	7A-AD	7CB8	-	048.092	7F01-11	7A-6F	-	7F01-31	-	7A-DE			
35	RIGHT	-	-	-	-	7A-12	7CB6	-	048.091	7F01-12	7A-6C	7A06	7F01-32	-	7A-9E			
36	RETURN	-	-	-	-	7A-AF	7CB7	-	048.131	7F01-13	7A-71	-	7F01-33	-	7A-AA			
37	DOWN	-	-	-	-	7A-11	7CB3	-	048.089	7F01-14	7A-6B	-	7F01-34	-	7A-9C			
38	DISPLAY	-	-	790A	7F9E	7A-B0	7CA6	-	048.015	7F01-15	7A-72	-	7F01-35	7C13	7A-C2			
39	VOL down	O	7A-1B	VOL DOWN														
40	REC	-	-	7A4F	-	-	7C8B	(VCR REC)	048.055	7F01-16	-	7A04	7F01-36	-	(device)			
41	STOP	-	-	7A09	7F84	-	7C85	(VCR Stop)	048.049	7F01-1D	-	7A03	7F01-3D	7C5B	(device)			
42	PAUSE	-	-	7A09	7F83	-	7C83	(VCR Pause)	048.048	7F01-1A	-	-	7F01-3A	7C5A	(device)			
43	PLAY	-	-	7A08	7F82	-	7C82	(VCR Play)	048.044	7F01-1E	-	7A00	7F01-3E	7C05	(device)			
44	REW (SEARCH -)	-	-	7A0D	7F88	7A-A4	7C86	(VCR REW)	048.041	7F01-17	-	7A01	7F01-37	7C06	(device)			
45	FF (SEARCH +)	-	-	7A0C	7F89	7A-A5	7C87	(VCR FF)	048.040	7F01-18	-	7A02	7F01-38	7C07	(device)			
46	SKIP -	-	-	7A0B	7F86	7A-A6	7CB9	-	048.033	7F01-1B	-	7A07	7F01-3B	7C02	(device)			
47	SKIP +	-	-	7A0A	7F87	7A-A7	7CBA	-	048.032	7F01-1C	-	7A00	7F01-3C	7C03	(device)			
48	1	-	-	7911	7F91	7A-E5	7C94	-	048.001	7F01-01	7A-61	-	7F01-21	7C17	7A-59			
49	2	-	-	7912	7F92	7A-E6	7C95	-	048.002	7F01-02	7A-62	-	7F01-22	7C18	7A-58			
50	3	-	-	7913	7F93	7A-E7	7C96	-	048.003	7F01-03	7A-63	-	7F01-23	7C19	7A-94			
51	4	-	-	7914	7F94	7A-E8	7C97	-	048.004	7F01-04	7A-64	-	7F01-24	7C1A	7A-56			
52	5	-	-	7915	7F95	7A-E9	7C98	-	048.005	7F01-05	7A-65	-	7F01-25	7C1B	7A-8D			
53	6	-	-	7916	7F96	7A-EA	7C99	-	048.006	7F01-06	7A-66	-	7F01-26	7C1C	7A-95			
54	7	-	-	7917	7F97	7A-EB	7C9A	-	048.007	7F01-07	7A-67	-	7F01-27	7C1D	-			
55	8	-	-	7918	7F98	7A-EC	7C9B	-	048.008	7F01-08	7A-68	-	7F01-28	7C1E	7A-DD			
56	9	-	-	7919	7F99	7A-B1	7C9C	-	048.009	7F01-09	7A-69	-	7F01-29	7C1F	-			
57	0	-	-	7910	7F90	7A-B2	7C93	-	048.000	7F01-0A	7A-60	-	7F01-2A	7C16	-			
58	+10	-	-	791A	7F9A	-	7C9D	-	-	7F01-0B	-	-	7F01-2B	7C5D	-			
59	ENTER	-	-	790B	7F8A	7A-B3	7C9E	-	-	7F01-0C	7A-BF	-	7F01-2C	7C15	-			

● RAV28 RX-V361 (B, G, E models), THR-6030 (G, E models)

• SCHEMATIC DIAGRAM

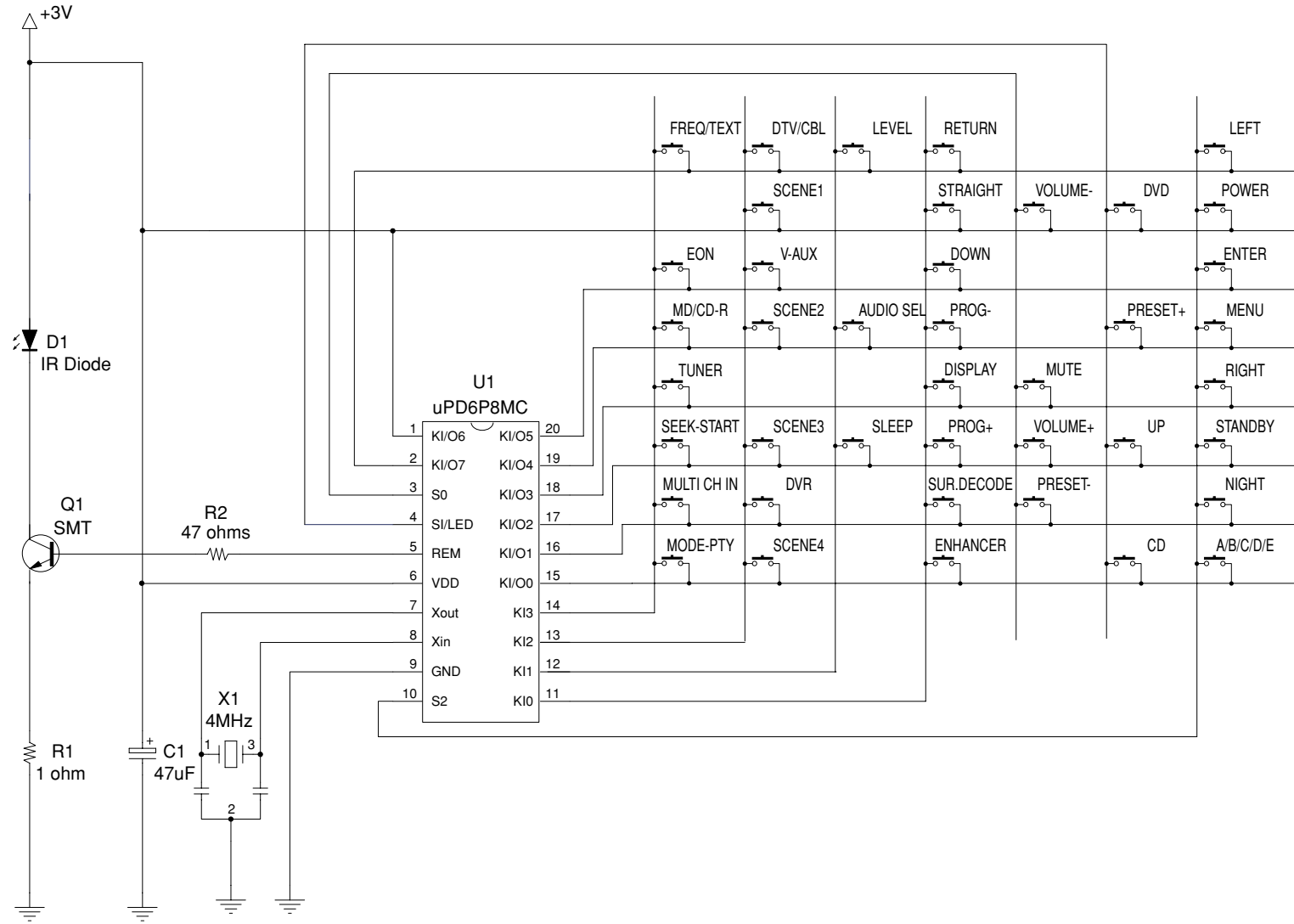

• PANEL

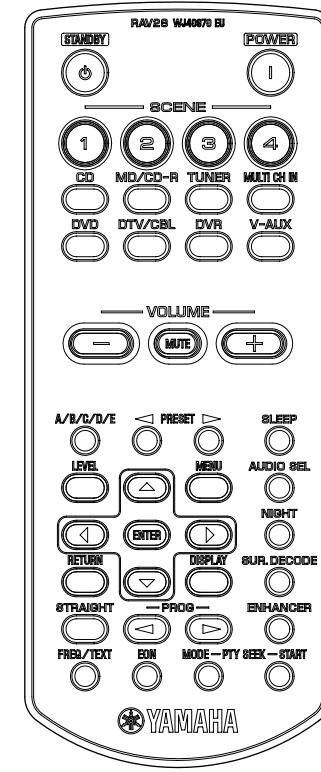

• KEY NO. LAYOUT

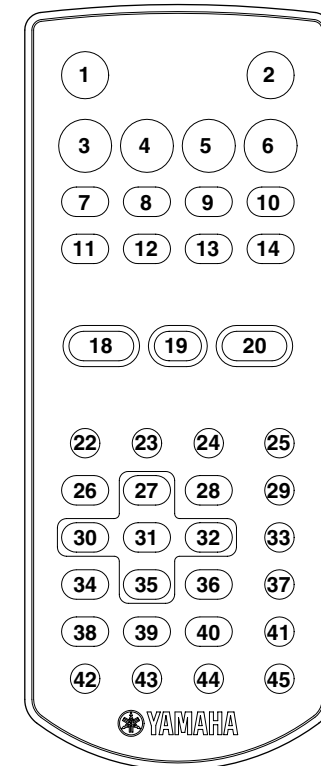

• KEY CODE

Key No.	Key Name	Custom Code	Data Code
1	STANDBY	7E	7F
2	POWER	7E	7E
3	SCENE1	7A	007F
4	SCENE2	7A	037C
5	SCENE3	7A	0679
6	SCENE4	7A	0976
7	CD	7A	15
8	MD/CD-R	7A	C9
9	TUNER	7A	16
10	MULTI CH IN	7A	87
11	DVD	7A	C1
12	DTV/CBL	7A	54
13	DVR	7A	13
14	V-AUX	7A	55
18	VOLUME-	7A	1B
19	MUTE	7A	1C
20	VOLUME+	7A	1A
22	A/B/C/D/E	7A	12
23	PRESET-	7A	11
24	PRESET+	7A	10
25	SLEEP	7A	57
26	LEVEL	7A	86
27	UP	7A	9D
28	MENU	7A	84
29	AUDIO SEL	7A	C3
30	LEFT	7A	9F
31	ENTER	7A	DE
32	RIGHT	7A	9E
33	NIGHT	7A	95
34	RETURN	7A	A4
35	DOWN	7A	9C
36	DISPLAY	7A	C2
37	SUR.DECODE	7A	8D
38	STRAIGHT	7A	56
39	PROG-	7A	59
40	PROG+	7A	58
41	ENHANCER	7A	94
42	FREQ/TEXT	7A	A4
43	EON	7A	A5
44	MODE-PTY	7A	A6
45	SEEK-START	7A	A7

Advanced setup

This unit has additional menus that are displayed in the front panel display. The advanced setup menu offers additional operations to adjust and customize the way this unit operates. Change the initial settings (indicated in bold under each parameter) to reflect the needs of your listening environment.

Notes

- Only **STANDBY/ON**, **PROGRAM** </> and **STRAIGHT** are effective while you are using the advanced setup menu.
- No other operations can be made while you are using the advanced setup menu.
- The advanced setup menu is only available in the front panel display.

1 Press STANDBY/ON on the front panel to set this unit to the standby mode.

2 Press and hold TONE CONTROL and then press STANDBY/ON to turn on this unit.

This unit turns on, and the advanced setup menu appears in the front panel display.

3 Press PROGRAM </> to select the parameter you want to adjust.

The name of the selected parameter appears in the front panel display.

4 Press STRAIGHT repeatedly to change the selected parameter setting.

5 Press STANDBY/ON to confirm your selection and set this unit to the standby mode.

*:

The settings you made are reflected next time you turn on this unit.

Speaker impedance SP IMP. (U.S.A. and Canada models only)

Use this feature to set the speaker impedance of this unit so that it matches that of your speakers.

- Choices: **8Ω MIN**, **6Ω MIN**
- Select “**8Ω MIN**” to set the speaker impedance to 8 Ω.
- Select “**6Ω MIN**” to set the speaker impedance to 6 Ω.

SP IMP.	Speaker	Impedance level
8Ω MIN	Front (A or B)	The impedance of each speaker must be 8 Ω or higher.
	Center	
	Surround	
6Ω MIN	Front (A or B)	The impedance of each speaker must be 6 Ω or higher.
	Center	
	Surround	

Factory presets PRESET

Use this feature to reset all the parameters of this unit to the initial factory settings.

- Choices: **CANCEL**, **RESET**
- Select “**CANCEL**” not to reset any parameters of this unit.
- Select “**RESET**” to reset the parameters of this unit.

Notes

- This setting completely resets all the parameters of this unit including the set menu parameters. However, the advanced setup menu parameters will not be initialized.
- The initial factory settings are activated next time you turn on this unit.

Tuner frequency step TU (Asia and General models only)

Use this feature to set the tuner frequency step according to the frequency spacing in your area.

- Choices: **AM10/FM100**, **AM9/FM50**
- Select “**AM10/FM100**” for North, Central and South America.
- Select “**AM9/FM50**” for all other areas.

すべての設定を初期設定に戻す

変更したセットメニューの設定や音場パラメーター、登録（プリセット）されたFM/AM放送局などをすべて初期設定に戻します。

ご注意

- 操作をしているあいだは、本機から音が出なくなります。
- 操作をはじめると、本体のSTANDBY/ONスイッチ、TONE CONTROLキー、STRAIGHT/EFFECTキー、PROGRAM </>キー以外は機能しなくなります。

4 STANDBY/ONスイッチを押す。

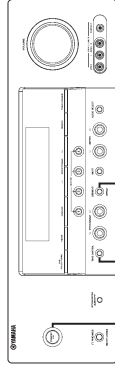

「CANCEL」を選んだ場合は初期設定に戻らずに、本機の電源はそのままスタンバイになります。「RESET」を選んだ場合は、次回電源をオンにしたときにすべての設定が初期設定に戻ります。

1 本体のSTANDBY/ONスイッチを押して、本機の電源をスタンバイにする。



2 TONE CONTROL キーを押しながら、もう一度 STANDBY/ON スwitchを押す。

本機の電源がオンになり、フロントパネルディスプレイに「PRESET - CANCEL」と表示されます。



押しながら

3 STRAIGHT/EFFECT キーを押して、「CANCEL」または「RESET」を選ぶ。



CANCEL：初期設定に戻しません。
RESET：すべての設定を初期設定に戻します。

ADVANCED OPERATION

English

RX-V361/HTR-6030/DSP-AX361

